



# Rechargeable LV Battery User manual

BXB 5KLV-PRO

Ver 1.1

## Revision History

Date	Revision	Description	Owner
2024-05-24	V1.0	Initial Release	WR WU
2024-07-12	V1.1	Add a lamp description	WR WU

## Before installation, Please read this guide.

1. Read this guide carefully before installation to understand product features and safety precautions.
2. Installers should be well trained to fully understand grid-connected photovoltaic power systems and national/regional standards.
3. Installers must use insulated tools and wear safety equipment.
4. As required by local regulations, an overcurrent protection and isolation device that operates both positive and negative conductors simultaneously is required between inverter and battery system and also between parallel batteries. The cable needs to be prepared by the installer, cable specification: 25mm<sup>2</sup> / 4 AWG, cable terminal model: E25-16.
5. Before installation, ensure that battery pack is switched off, and open any associated circuit breakers and disconnect switches.



# Contents

---

1. Detailed Specifications .....	1
2. Product Packing List .....	2
3. Installation environment requirements .....	3
4. Product Appearance .....	3
5. Installation .....	5
5.1 Battery Installation .....	5
5.2 Single Unit Connection .....	7
5.3 Multi-Unit Connection with Bus-Bars (3-Unit Example) .....	11
5.4 Multi-Unit Connection without Bus-Bars (3-Unit Example) .....	11
6. Manufacturing Cables When Required.....	11
6.1 Power Cable .....	13
6.2 Communication Cable .....	14
7. Other .....	15
8. Routine maintenance.....	15
9. Recycling disposal .....	15

## 1 Detailed Specifications

Item Name	Specification	Remark
Rated Capacity	100 Ah	
Rated Voltage	51.2 V	
Rated Current	0.6C, 60 A	
Working Voltage Range	44.8-58.4 V	
Rated Energy	5.12 kWh	
Max. Parallel Quantity	Max. 32 Sets In Parallel, 163.84 kWh	
Rated Charging Current	0.6C, 60 A	
Max. Charging Continuous Current	0.6C, 60 A	
Rated Discharge Current	0.6C, 60 A	
Max. Discharge Continuous Current	1C, 100 A	
Battery Max. Charge/Discharge Power	3.07 kW/5.12 kW	
Peak Discharge Current / Power	105 A/5.37 kW, 1min	
Standard Charging Method	0.5C CC to 57.6 V; CV at 57.6 V Till Current Is 0.05C	
Available SOC Range	0% ~ 100%	90% DOD is Recommended.
SOC Transportation Range	50%	
Dimensions [W*D*H]	Width: 460 (±5) mm/18.11 in, Depth: 165 (±5) mm/6.5 in, Height: 652 (±5) mm/25.67 in,	
Weight	~50 kg	
Operating Temperature <sup>1</sup>	Charging Temperature: -5 C ~55 C Discharge Temperature: -15 C ~55 C	
Storage Temperature <sup>2</sup>	-15°C ~ 55 °C	
Working Humidity	<95% RH (non-condensing)	
Altitude <sup>3</sup>	≤2000 m	
Communication	CAN, RS485, Dry Contact, WiFi	WiFi Stick Option
Certificate	IEC 62619, IEC62040, IEC61000, UN38.3	
Designed Cycle Life (25 C ±2 C)	6000 Cycles	0.5C/80%DOD/80%SOH/ 1 cycle per day
Designed Calendar Life <sup>4</sup>	15 Years	Working Condition 0.5C @ 25 deg C, 80% DoD, 1 cycle per day
IP Rating	IP65	
Cooling	Natural Cooling	
Heating Power	230.4 W	
Environment Protection Standard	RoHS	

1. Recommended operating temperature: 10 ~ 30 C .

2. Recommended Storage temperature: 10 ~ 30 C .

3. Recommended working height is less than 2000 m, and the max. working height is 3000 m.

4. For details, please refer to the catalog 6 Disclaimer

## 2 Product Packing List

Check the scope of delivery for completeness and any visible external damage. Contact your supplier if the package is damaged upon delivery or is incomplete or damage

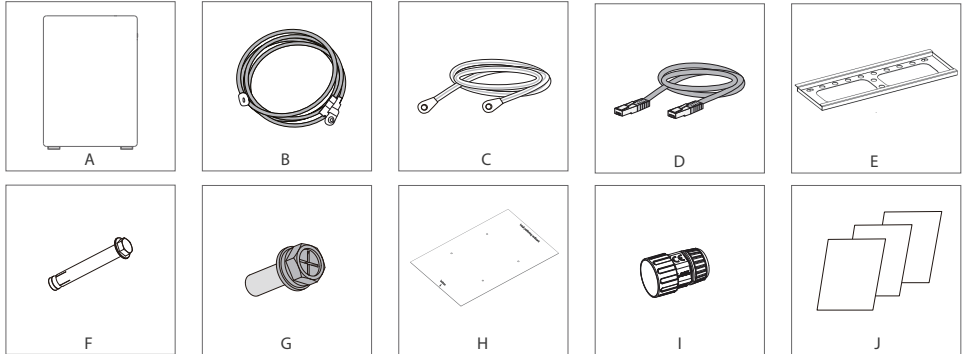

Object	Item Name	Details	Quantity	Notes
A	Battery	460x165x652 mm 18.11x6.50x25.67	1	
B	Output Cable	Positive: orange plug, 25 mm <sup>2</sup> / 4 AWG, L:1.5 m to SC25-8 ring terminal. Negative: black plug, 25 mm <sup>2</sup> / 4 AWG, L:1.5 m to SC25-8 ring terminal	1 set	Continuous flow capacity: 100A
C	Grounding Cable	Ground cable yellow & green / L:1 m / double OT M6	1	
D	Communication cable	Standard network cable black / L:1.5 m / Double RJ45 Plug	1	
E	Back Plate		1	
F	Expansion Screw	M8*80mm	4	
G	Screw	M5*16 mm	2	
H	Mounting Positioning Board		1	
I	RJ45 Water proof Wiring Terminal		3	
J	Manual/shipping list /shipping report		3	

### 3 Installation environment requirements

1. Ensure that the equipment is installed in a dry and well-ventilated environment.
2. The installation position must be away from direct sunlight and rain.
3. The installation position must be far away from fire sources.
4. The installation position must be far away from water sources such as taps, sewer pipes, and sprinklers to prevent water seepage.
5. Do not expose the equipment to flammable or explosive gas or smoke.
6. Humidity: <95%RH (non-condensing); Operating temperature: -15°C~+55°C.

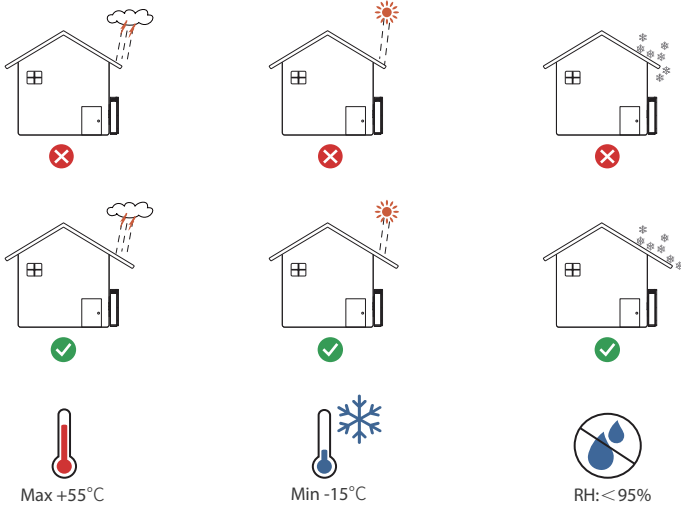

### 4 Product Appearance

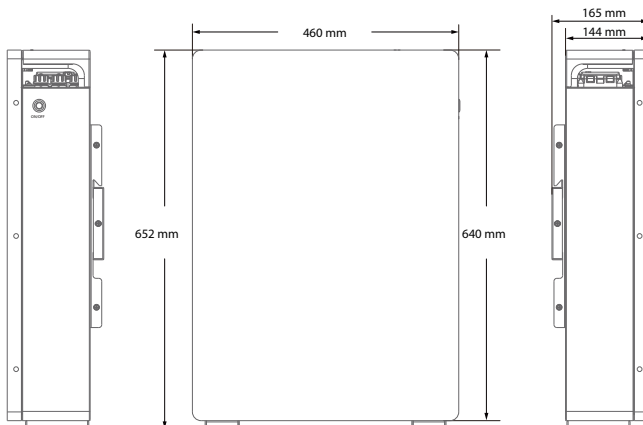

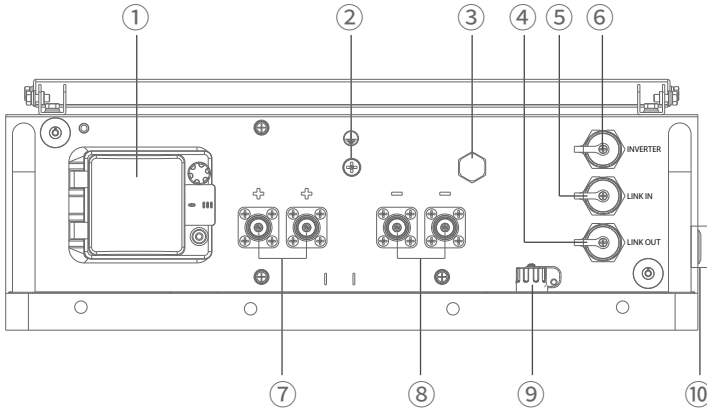

Number	Name	Details	Notes
1	125 A DC Breaker		
2	GND	M6	Yellow-Green, 10 AWG
3	Breather Valve		
4	LINK OUT	RJ45	Internal RS485 communication between batteries
5	LINK IN	RJ45	Internal RS485 communication between batteries
6	INVERTER	RJ45	CAN communication to the inverter
7	Port Positive x2	PSR6XCBM5A	Red cable 25 mm <sup>2</sup> / 4 AWG, cable plug model: PSRP6XC25A
8	Port Negative x2	PSR6XABM5A	Black cable 25 mm <sup>2</sup> / 4 AWG, cable plug model: PSRP6XA25A
9	WiFi Socket		For optional WiFi stick
10	Power Switch		Red light: ALM, Blue light: RUN

**RJ45 Port Pin Definition**

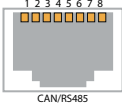
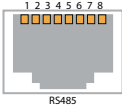
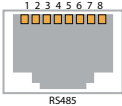
View	Item	Description	1	2	3	4	5	6	7	8
 <p>CAN/RS485</p>	2	INVERTER	-	RS485-A	RS485-B	CAN-H	CAN-L	GND	-	-
 <p>RS485</p>	3	LINK IN	-	BMS-RS485-A	BMS-RS485-B	DI+	DI-	-	BMS-CAN-H	BMS-CAN-L
 <p>RS485</p>	4	LINK OUT	-	BMS-RS485-A	BMS-RS485-B	DO+	DO-	-	BMS-CAN-H	BMS-CAN-L

## 5 Installation

### 5.1 Battery Installation

#### 5.1.1

1. Measure the mounting space (position a cardboard the same size as the battery).
2. Mark the fixed position with the "mounting locating plate(l)".

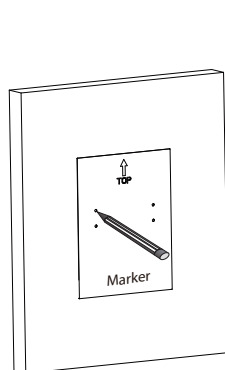
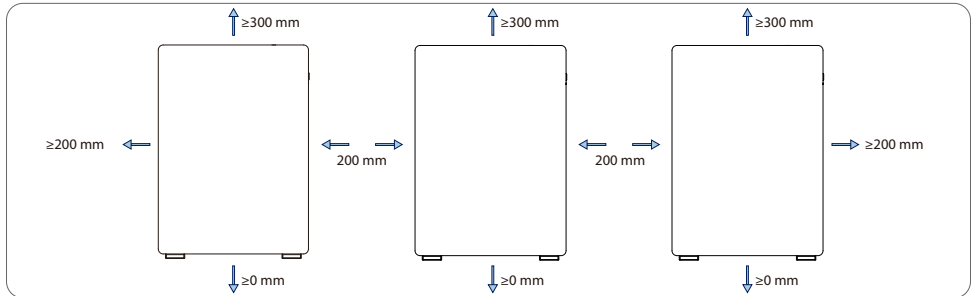

Note: Ensure that the mounting locating plate is level with the floor.

5.1.2

1. Use an impact electric drill to drill holes in the concrete or stone (fireproof) wall, the drilling depth is between 80mm and 85mm: The drill diameter is 12 mm.
2. Tighten the expansion bolt (G) slightly and put it into the hole. Knock the expansion bolt with a rubber hammer until all the expansion pipes enter into the hole.
3. Pre-tighten the expansion bolt.
4. Screw out the bolts and remove the spring washer and flat washer.

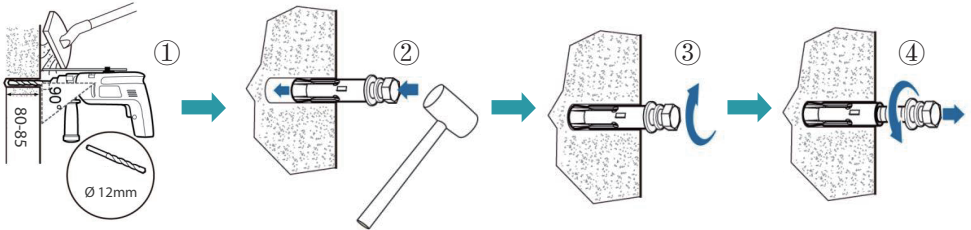

Note: Expansion bolts are mainly used for solid brick-concrete walls and concrete floors. If you choose other types of walls and floors, ensure that they meet the load-bearing requirements and select the bolts yourself.

5.1.3

1. Fix the "Back Plate (E)" to the wall.
2. Hang the battery on the bracket according to the picture below.
3. Secure the PACK from the side using screws (H).

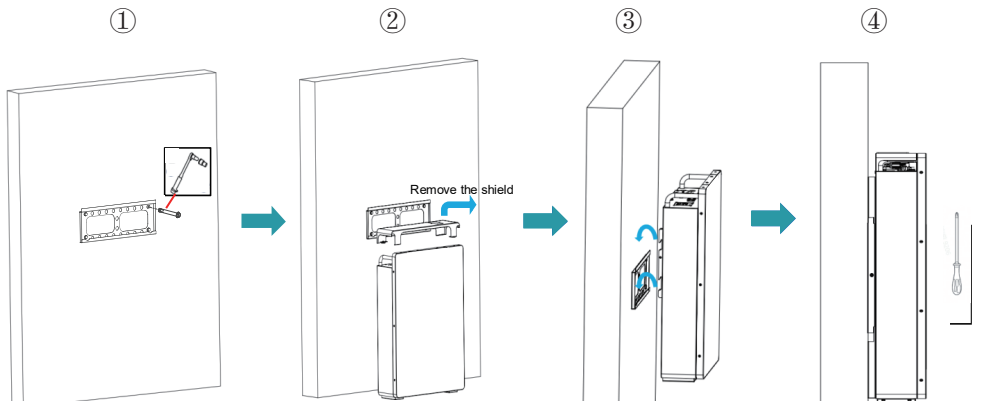

## 5.2 Single Unit Connection

1. The rated output power of the cable connection is 3 kW; SOC>70% The output power is 5 kW.
2. Install circuit breakers based on local regulations.

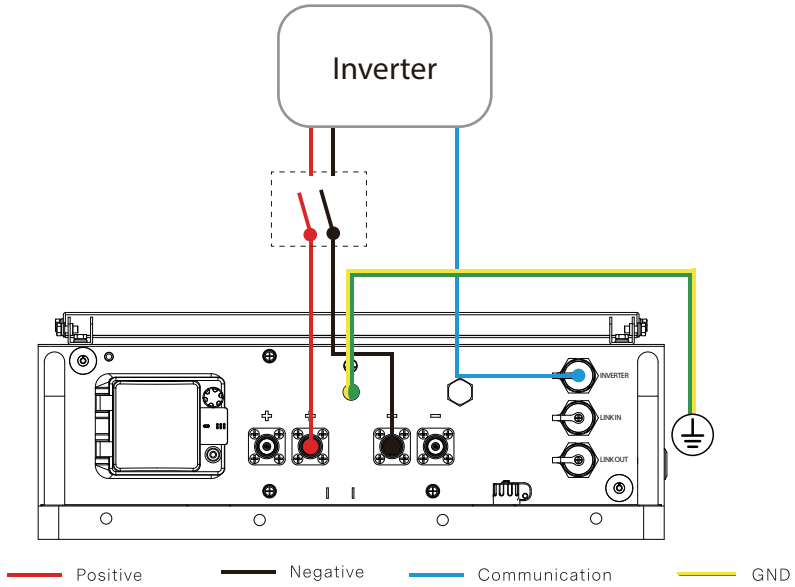

**⚠** Note: Before electrical connection, ensure that the circuit breaker/power switch of the battery and all switches connected to the energy storage are in the OFF state. Otherwise, electric shock may occur.

### 5.2.1 Ground Connection

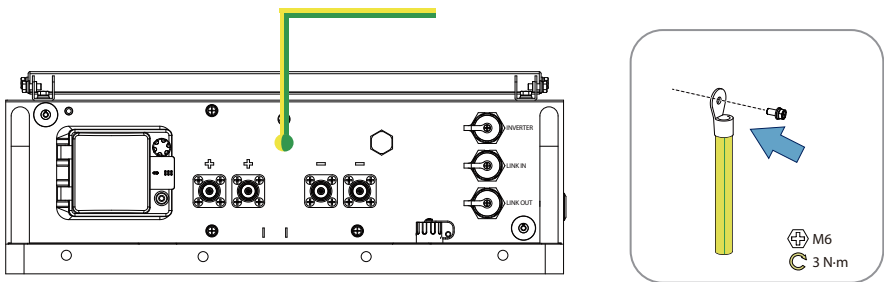

### 5.2.2 Communication Connection

1. Route the communications cable through the RJ45 cable cover (J) .
2. Connect the communications cable to the RJ45 port (marked "Inverter").
3. Tighten the RJ45 cable cover.
4. Connect the other end of the communication cable to the inverter.

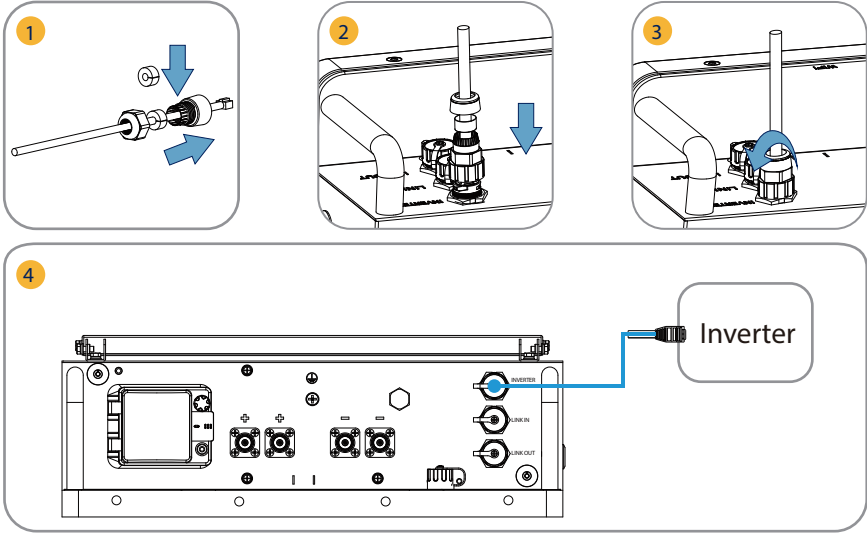

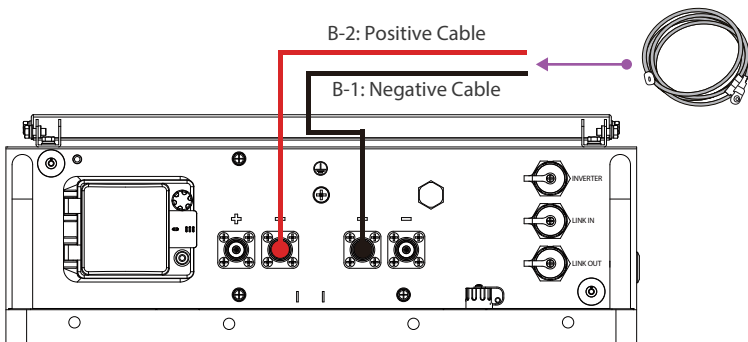

### 5.2.3 Power Cable Connection



### 5.2.4 Activate Battery



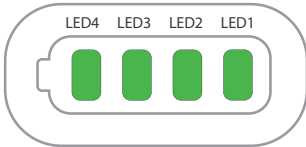

1. Turn on the circuit breaker while the power switch is off.
2. Turn on Power Switch to start battery. After five seconds, Blue indicator Steady on indicates normal operation.
3. Cover with the front cover after checking.

State	Working		Failure		
Button					
Remarks	The light is always on		Flicker/Persist		
	When the battery starts up, the red and blue lights alternately flash, indicating that the battery self-test is normal.				
Indicator	Standby		Charging		Discharge
	SOC indicator steady green diode = 25%)		1 Leftmost soc indicator blinks (pattern 2)		All soc indicators blinks (pattern 1)
					

### 4. LED Flashing Status

Status	On	Off
Flashing 1	0.25s	3.75s
Flashing 2	0.5s	0.5s
Flashing 3	0.5s	1.5s

### 5. SoC Indicator

SoC	LED			
				
	LED1	LED2	LED3	LED4
[0~25%)	On	Off	Off	Off
[25%~50%)	On	On	Off	Off
[50%~75%)	On	On	On	Off
[75%~100%]	On	On	On	On

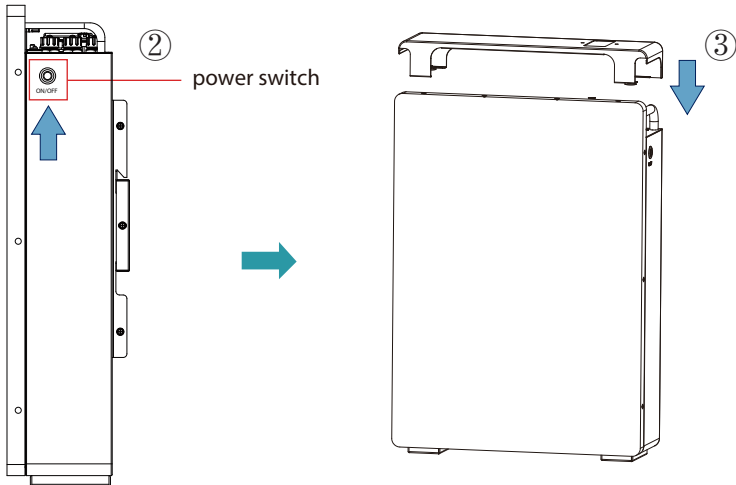
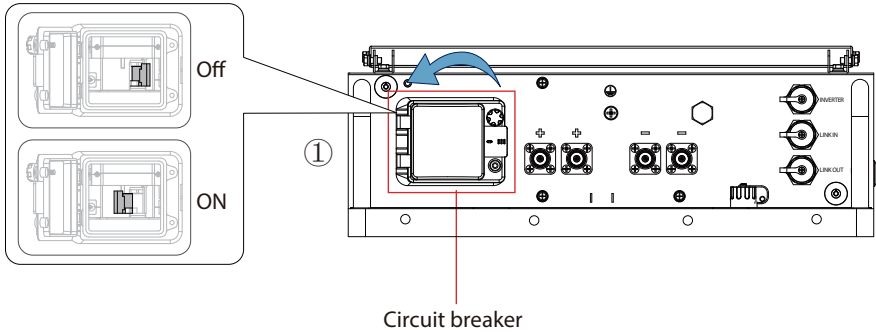

### 5.3 Multi-Unit Connection with Bus-Bars (3-Unit Example)

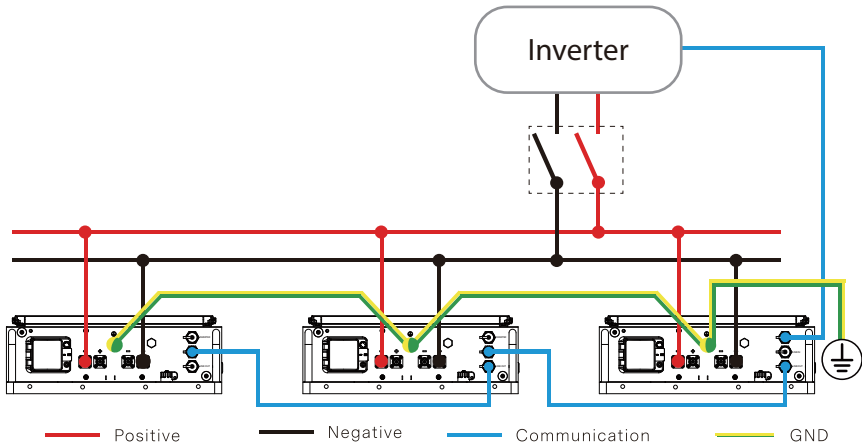

1. The method of cable connection with a bus-bar will output a power of  $3 \times 3 \text{ kW} = 9 \text{ kW}$ , and at a state-of-charge (SOC) over 70%,  $3 \times 5 \text{ kW} = 15 \text{ kW}$ .
2. Max. number of parallel units: 32. Note that the max. recommended charge and discharge power is 96 kW continuous and 160kW peak.
3. Install circuit breakers based on local regulations.

#### 5.3.1 Ground Connection

Please follow step 4.2.1.

#### 5.3.2 Parallel communication

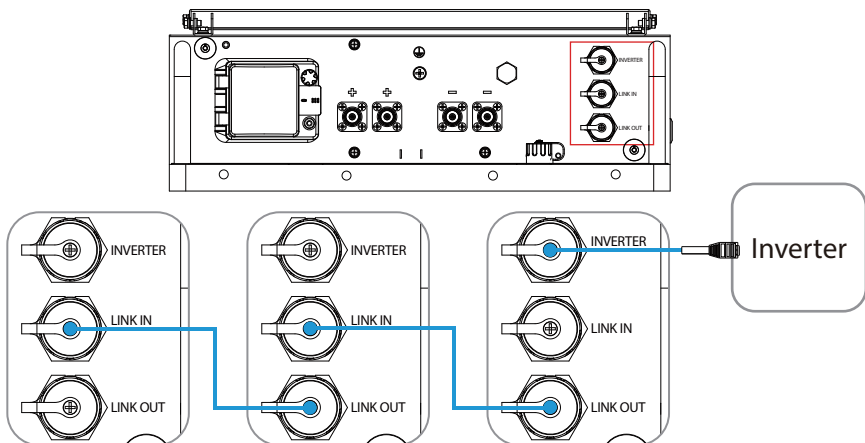

For details about communication wiring follow step 4.2.2.

### 5.3.3 Power Cable Connection

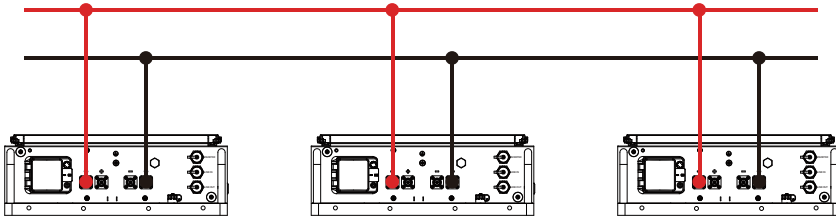

### 5.3.4 Activate Battery Bank

Please follow step 4.2.4. Make sure all breakers are turned on before pressing the power switches on all batteries.

### 5.4 Multi-Unit Connection without Bus-Bars (3-Unit Example)

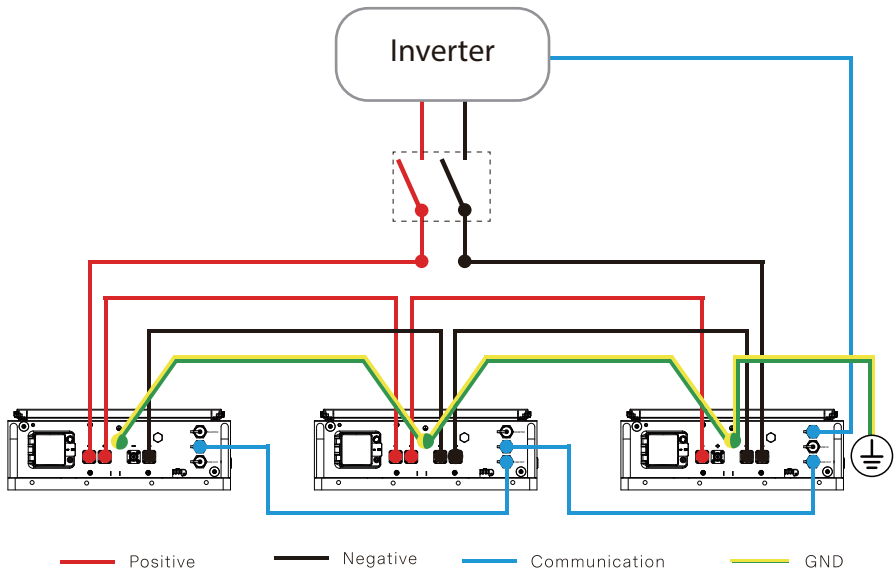

1. This wiring method will allow a max. power output of 5 kW continuous, limited by the wiring and connectors. Make sure the connected inverter does not exceed 5 kW/100 A continuous during both charge and discharge.
2. Install circuit breakers based on local regulations.

### 5.4.1 Ground Connection

Please follow step 4.2.1.

### 5.4.2 Communication Connection

Please follow step 4.2.2.

### 5.4.3 Power Cable Connection

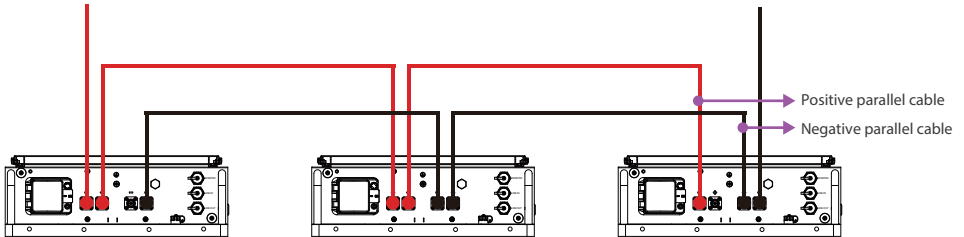

Note: Parallel cable needs to be purchased extra.

### 5.4.4 Activate Battery Bank

Please follow step 4.2.4. Make sure all breakers are turned on before pressing the power switches on all batteries.

## 6 Manufacturing Cables When Required

### 6.1 Power Cable

6.1.1 Material List (plug components may be purchased separately from supplier)

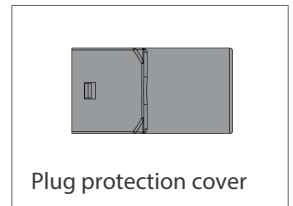
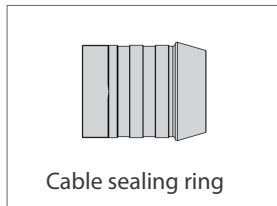
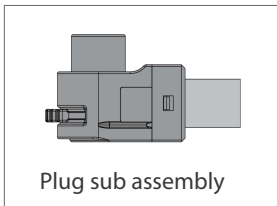

**Steps:**

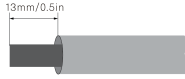
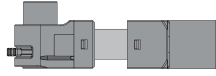
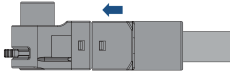
Procedure	Schematic picture
1.Route the cable through the isolation cable sealing ring and Plug protection cover.	
2.Remove 13mm of insulation at end of cable.	
3.The red plug is used for the positive, and the black is for the negative power cable. The end of the cable is crimped at the terminal using a crimping clamp.	
4.Tighten the isolation cap and plug contact.	
5.Put the positive and negative plug on to the system and tighten them.	
6.Use isolation cap for unused DC plug.	

## 6.2 Communication Cable

### 5.2.1 Battery to Battery Communication Cable

Pin definition as below, alternatively a standard straight CAT 5 Ethernet cable can be used.

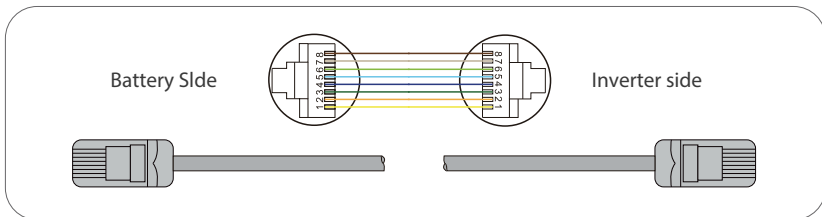

### 6.2.2 Battery to Inverter Communication Cable

Pin definition as below, alternatively a standard straight CAT 5 Ethernet cable can be used., For the inverter end pin definition, see the inverter specification.

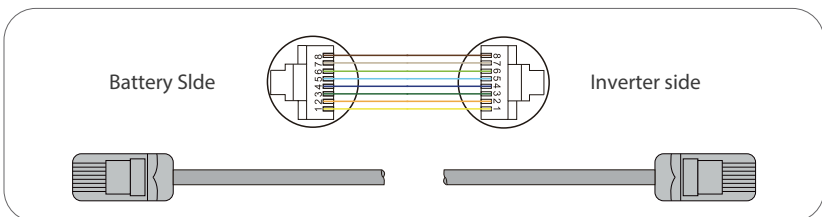

## 7 Other

Install an isolation device (i.e. a circuit breaker) between the inverter and the battery system to run both positive and negative conductor overcurrent protection. The steps for installing isolation devices (i.e. circuit breakers) are as follows:

1. Use E25-16 terminals to connect the wiring harness to the isolation device.
2. Insert the wiring harness terminal into the connection port of the isolation device, and distinguish the positive and negative terminals of the isolation device (see the isolation device specifications for details);
3. Tighten the wiring harness terminal with screws to secure it.

Note: During installation, please turn off the battery power switch and check whether the power is off. The cable from the circuit breaker to the inverter is provided by the installation personnel. (Please refer to the Product Packaging List for cable specifications)

## 8 Routine maintenance

To ensure the long-term running of the energy storage system, you are advised to maintain batteries regularly.

Check content	Inspection method	Maintenance cycle
System cleanliness	Check whether the appearance of the system is damaged or deformed.	Once every 6 to 12 months
System running state	1. Check that the battery does not generate abnormal sound when it is in operation. 2. Check that the battery parameters are correctly set when the battery is running.	Once every 6 months
Electrical connection	1. Check that cables are secured. 2. Check that cables are intact, and that in particular, the parts touching the metallic surface are not scratched.	Once every 6 months
Ground reliability	Check that ground cables are securely connected.	The first inspection is 6 months after the initial commissioning. From then on, the interval can be 6 to 12 months.

## 9 Recycling disposal

The batteries may only be disposed of in accordance with the disposal regulations for used batteries applicable at the time of disposal. Immediately decommission any damaged batteries and please contact your installer or sales partner first before disposal. Ensure that the battery is not subjected to moisture or direct sunlight. Ensure quick removal by your installer.

- Batteries, including rechargeable batteries, may not be disposed of in household waste. You are legally obligated to return used batteries.
- Used batteries may contain pollutants that can damage the environment or harm your health if they are not stored or disposed of properly
- Batteries also contain important raw materials such as iron, zinc, manganese, copper, cobalt or nickel and can be recycled.

Do not dispose of batteries in household waste!





BEXIE GROUP S.L.

Email: [info@bexiegroup.com](mailto:info@bexiegroup.com)

Tel: 34 985194232