



bexieenergy.com

This brochure is a publication from BEXIE GROUP.

Vanward makes reservations for any factual or printing errors in this brochure.

+34 985 194 232

Calle Peña Santa 68, Polígono Industrial Silvota,
33192, Llanera, Asturias

www.bexieenergy.com

BEXIE GROUP designs, manufactures and delivers high-performance solar electric technology worldwide.



BEXIE 2 Guns DC EV Small Charging Station



Foreword

1. Overview

- 1.1 Product Introduction
- 1.2 Product conceptual diagram
- 1.3 Main Parameters
- 1.4 Product performance and characteristics
- 1.5 The overall function of charging pile is introduced
- 1.6 Product usage environment
- 1.7 Product design specifications

2. Install

- 2.1 Security Description
- 2.2 Installation condition
- 2.3 Handling packing boxes
- 2.4 Unpack
- 2.5 Handling charging piles
- 2.6 Requirements for concrete foundation fabrication
- 2.7 Install charging piles
- 2.8 Cable access
- 2.9 Network Options
- 2.10 OCPP platform and network connection
- 2.11 Charger installation acceptance

3. Operation instructions and precautions Condition

- 3.1 Pre-use safety check
- 3.2 Operational precautions
- 3.3 language selection
- 3.4 Charging status description
- 3.5 Indicator lamp description
- 3.6 Instructions for use of emergency stop switch
- 3.7 Charging system host computer software description

02

02

03

04

04

06

06

06

06

07

07

08

09

10

11

11

12

13

16

16

16

17

18

21

21

21

4. Packing,Transport,and Storage

22

5. Ordering Instructions and after-sales service

23

5.1 Ordering Instructions

23

5.2 After-sales Service

23

5.3 Accessories List

23

5.4 Nameplate

23

The appendix

Appendix I Troubleshooting list (please refer to this for solutions according to descriptions)

Appendix II Electrical schematic diagram

Appendix III Charging pile equipment maintenance guide

Appendix IV Product warranty card

Before an operation, please read the operation manual to know the correct way to use the equipment. Please keep it for future reference.



WARNING

There are dangerous high voltage input and output in this equipment, which will endanger human life. Please strictly follow all signs and operating instructions on the machine and in the manual. Unauthorized professional maintenance personnel must not to remove the outer cover of the device.

Foreword

BEXIE GROUP, we are a leading brand that produces thousands of high-quality inverters, batteries, heat pumps and ev chargers every year through solar PV, energy storage, heating and electric mobility systems. At the same time, the electric vehicle charging station is not only beautiful in design, but also easy to operate; It also has reliability and robustness. Charging pile product types are rich, can meet the various needs of customers, there are wall-mounted, vertical cabinet, split charging pile; Wide output power range, from 20kW to 600kW; It has passed UL, CE, CB, RCM, UKCA, CCC and RoHS certification. At the same time, it has dynamic load balancing and PEN fault detection functions.

Safety Precautions

- Do not put inflammable, explosive, or combustible materials, chemicals, combustible steam, and other dangerous materials near the charger.
- Keep the connector clean and dry. If there is dirt, please wipe it with a clean, dry cloth. Please do not touch the connector core with your hand when charged.
- It is strictly prohibited to use the charger when the connector or the cable is defective, cracked, worn, or broken or when the cable is exposed. If these situations are found, please get in touch with the staff in time.
- Do not attempt to disassemble, repair, or modify the charger yourself if you are not a professional. If you have any repair or modification needs, please contact the staff.
- Please carefully read and follow the rules for the use of charging piles to ensure proper operation. Improper operation may cause damage, water leakage, electric leakage, etc.
- Removing the connector during the charging session is strictly prohibited to ensure the safety of personnel and the vehicle.
- If there is any abnormal situation during usage, you can immediately press the emergency stop button to cut off all input and output currents.
- In case of rain and thunder, please charge with caution.
- Children should not approach or use the charger during the charging process to avoid injury.
- Please close the doors of chargers on both sides when it is working to avoid electric shock.
- During the charging process, the vehicle is not allowed to drive and can only be charged in a stationary state. Please turn off the hybrid electric vehicle before charging it.
- Any problems caused by illegal operations are not covered by the maintenance warranty and are at their own risk.
- Please dispose of waste in accordance with local laws and regulations.
- The test button for the leakage protector needs to be pressed every month to ensure that the leakage protector functions properly
- Every three months, it is necessary to check whether the screws inside the product are loose to avoid affecting product performance and safety

1. Overview

1.1 Product introduction

We, BEXIE GROUP proudly present this one piece DC EV charging station. It is mainly used for DC fast charging of electric vehicles, which integrates functions such as power conversion, charging control, human-computer interaction control, communication, billing and metering. It is composed of man-machine interactive touch screen, card reader, energy metering module, charging module, communication module, charging interface, control module and pile body. Optional cabinet heating system, smoke alarm system, fire extinguishing system, flood alarm system and so on. The product has good dust-proof, waterproof functions, protection level up to IP55, multiple protection functions, input and output dual safety protection, real-time monitoring of cable connection status, abnormal immediately stop charging, to ensure the safety of people and vehicles during charging. User-friendly interface display and control guide function, convenient to complete the charging process; CAN, Ethernet, RS485 and other communication interfaces are provided to connect the management center and monitor the charging status.

The power conversion unit of the charging pile follows the principle of modular design, and can be flexibly configured into 60kW-90kW and 120kW power output to meet the charging needs of electric vehicles with different capacities, which is the best choice for outdoor fast DC charging.



FIG. 1 Outside drawing of the charger

1.2 Product conceptual diagram

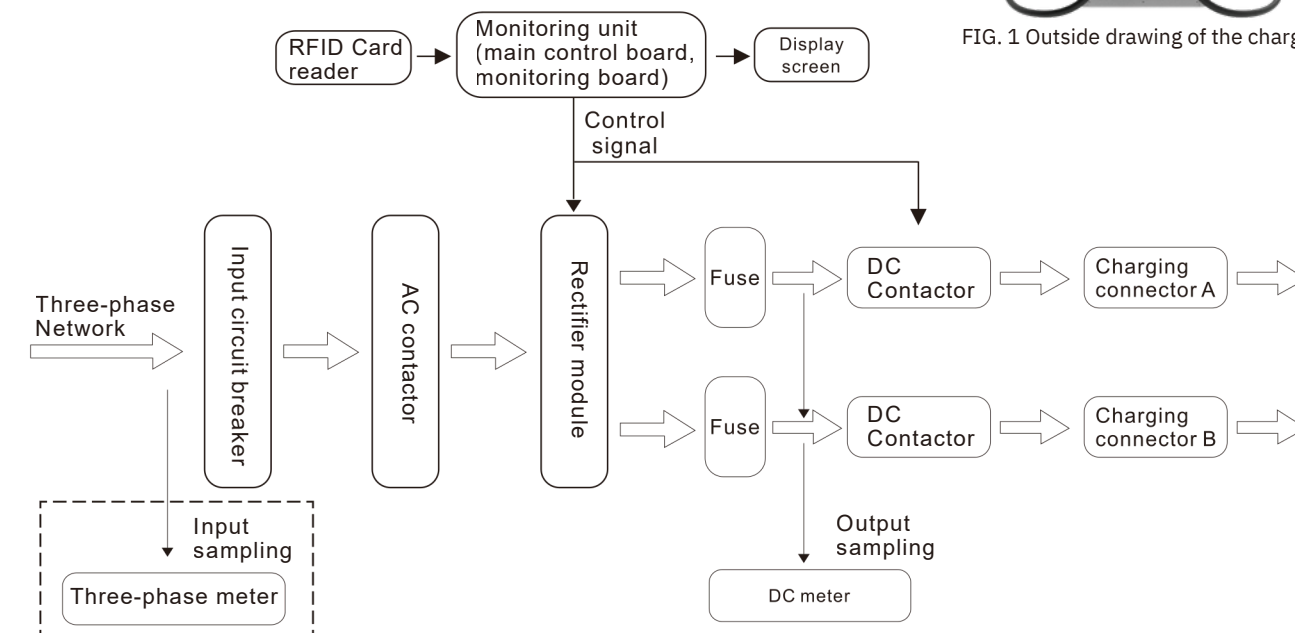

1.3 Main parameters

NO.	Article	Units	Standard
1	Rated AC input voltage	V	380-415Vac,3P+N+PE
2	AC power frequency	Hz	50/60
3	Input power factor		≥0.99(load 100%)
4	DC voltage regulation range	V	150V~1000V
5	Accuracy of current	%	≤±1
6	Voltage regulation accuracy	%	≤±0.5%(150~1000V,0~20MHz)
7	Accuracy of a steady flow	%	≤±0.5%(output load 20%~100%rated range)
8	Standby power consumption	W	≤0.1% rated output power
9	Input impulse current	A	≤110% Rated input current
10	Output overshoot voltage	V	≤110% Steady state output voltage
11	Unbalance degree of current equalization	A	≤5% Rated output current
12	Harmonic current limit requirements(THD)	%	≤5(Class A equipment)
13	Efficiency	%	≥95
14	Noise	dB	≤69
15	Oscillation immunity		Level 3(1MHz and 100kHz)
16	Electrostatic discharge immunity		Level 3
17	RF electromagnetic field immunity		Level 3
18	Electrical fast transient pulse group immunity		Level 3
19	Surge immunity		Level 3
20	Radiated disturbance immunity of RF field induction		Level 3
21	Power frequency field immunity		Level 4
22	Damped oscillatory field immunity		Level 4

1	LTE-FDD working frequency		B1/B2/B3/B4/B5/B7/B8/B12/B13/B18/B19/B20/B25/B26/B28
2	LTE-TDD working frequency		B38/B39/B40/B41
3	UMTS working frequency		B1/B2/B4/B5/B6/B8/B19
4	MIFARE working frequency	HZ	13.56MHZ±7K
5	2.4G WI-FI working frequency	HZ	2412MHZ-2484MHZ
6	2.4G WI-FI Maximum transmitting power	dBm	20.5dBm
7	WCDMA Maximum transmitting power	dBm	24dBm+1/-3dB
8	LTE-FDD Maximum transmitting power	dBm	23dBm±2dB
9	LTE-TDD Maximum transmitting power	dBm	23dBm±2dB
10	MIFARE Maximum transmitting power	dBuA/m	14.05dBuA/m

1.4 Product performance and features

Product function

- High-efficiency, low-harmonic, Class A quality. System efficiency ≥95%, industry-leading power density, low energy consumption, high energy efficiency. The charging module uses active power factor correction technology, harmonic interference ≤5% and power factor up to 0.98.
- Modular design, reliable system. The system adopts multi-module parallel output mode, flexible configuration, easy maintenance. Single module failure does not affect the system, which greatly improves system's reliability and stability.
- All-round protection to guarantee safety. self-check for input, output, and component and protection during operation and connection,
- input over/under voltage protection, DC output over-voltage/short circuit protection, module overheating/fault protection, insulation protection, charge, and car battery connection inspection and other multiple protection functions. All to ensure the safe and reliable operation of the system, effectively prevent the occurrence of accidents.
- Wide voltage output, easy to use: super wide constant power output voltage range. It has the characteristics of active power factor correction, high efficiency, high power density, high reliability, intelligent control, and beautiful shape. It can be adjusted in a wide range to meet the charging needs of different terminal voltages of battery banks, and can be used to charge electric vehicles of different voltage levels.

Product Features

- 32-bit high-performance embedded industrial processor as the central controller. Level I.0 multifunctional DC watt-hour meter to accurately measure vehicle charging amount.
- Using a contactless card reader in accordance with ISO 14443-A/B. And implement hardware encryption authentication processing on the card to ensure the security of the card account data.
- Using a 7-inch LCD touch screen, the display color is bright, can achieve outdoor high-brightness environment display, and can adapt to low temperature -30°C environment.
- With the charging gun fall off detection function, to ensure the use of safety during the charging process.
- The product communicates with the monitoring platform in real time through 4G, Ethernet, WiFi and CAN communication interfaces, and timely reports various records to ensure the real-time monitoring of the monitoring platform for the charging pile.
- The system software supports upgrades remotely locally.

1.5 The overall function of charging pile is introduced

1.5.1 Human-computer interaction interface

In the process of charging, the charging pile dynamically adjusts the number of charges according to the data provided by the battery management system, and performs corresponding operations to complete the charging process.

Indicates the output function

- Real-time display of charging voltage, charging current, SOC, charging time, metering, battery information and other information.
- When a fault occurs, the corresponding information is displayed.
- It can display the relevant information of each state of the charging pile.
- Displays other related information output by the monitoring unit.
- Can display electric vehicle battery information.

1.5.2 Self-test

Self-test of charging pile during power-on, including pile body, clock, power supply, storage space, etc. The fault information can be displayed through the status indicator or the display screen, and the fault information is recorded.

1.5.3 Software Upgrade

Chargers with a master monitoring system supports OTA and USB-OTA, and those without a master monitoring system only support USB-OTA.

1.5.4 Software Functions

Display function:

- Transmit
Charging pile reserve data transmission interface, collect and upload charging pile usage and charging information data and charging pile fault data.
- Store
Transaction data is stored as a record in non-volatile memory. Ensure that the stored data is correct, continuous, complete, and valid. Keep no less than 10,000 record space, and the charging pile can collect data in time when the transaction record is stored.

1.5.5 Control Functions

The charging monitoring unit can adapt to various operating modes of the charger, and realize the correct charging process of constant current limited voltage charging → constant voltage charging → stop charging.

1.5.5 Control Functions

The charging monitoring unit can adapt to various operating modes of the charger, and realize the correct charging process of constant current limited voltage charging → constant voltage charging → stop charging.

1.5.6 Alarm Function

When the charging pile is faulty, such as abnormal DC output, power module alarm/fault, DC output overvoltage/undervoltage, DC output overcurrent, switch trip/fuse failure on the input side of the charging pile, communication interruption between the charging monitoring unit and the partition monitoring module, and monitoring unit failure, the monitoring unit can issue an audible and visual alarm and output it on the display screen of the charging pile through the communication port.

1.5.7 Event Recording Function

Events such as charging pile failure and charging start/end time are recorded, and the stored data has the function of power failure retention.

1.5.8 Timing function

The charging pile can receive the timing command of the partition monitoring terminal for timing, meeting the requirements of PPS (second pulse) and PPM (sub-pulse) timing.

1.6 Product usage environment

- Altitude ≤2000 meters, above 2000 meters must be derated use.
- For the ambient temperature of the device, see the label on the device nameplate. If the temperature is higher than 55°C, the temperature must be derated. Air relative humidity Relative humidity ≤ 95%RH, no condensation.
- For outdoor operation, a sunshade and rainshade device should be installed above the equipment.
- The installation inclination should not exceed 5%.
- Keep inflammable and explosive materials away from the pile.
- Atmospheric pressure 79kPa ~ 106kPa.
- The pile body must have good permeability around.

1.7 Product design specification

Region	Standard
China	GB/T 18487.1-2023;GB/T 18487.2-2017;GB/T 18487.3-2001
The European Union	EN IEC 61851-1: 2019, EN 61851-23: 2014, EN 61851-24: 2014, EN IEC 61851-21-2: 2021, IEC 61851-1: 2017 IEC 61851-23: 2014, IEC 61851-24: 2014, EN IEC 61000-6-2: 2019, EN IEC 61000-6-4:2019

2. Install

2.1 Security Description

2.1.1 Note

Please read and follow the following safety instructions before installing, maintaining or using a charging post. Installers should ensure that charging stations are installed in accordance with the specific standards and local regulations of the relevant country/region. This manual contains important usage and installation instructions that must be followed when installing, using, and maintaining the unit.

2.1.2 Warning of the danger of electric shock

- Turn off the power to the charging station before installing or maintaining it. Turn off the power until the charging station is fully installed and the housing is in place and secured.
- In the event of hazards and accidents, a qualified electrician must disconnect the charging station from the power supply immediately.
- If the charging station is damaged, or the charging cable shows excessive wear or other visible signs of damage, do not operate the charging station. If you suspect that the charging station is damaged, contact the after-sales staff or your dealer.
- Do not use pressure water to clean the charging station, do not use wet hands, and do not immerse the charging gun in liquid.
- Do not place your fingers or other objects in the charging port or inside the gun.
- Before charging an electric vehicle, read the instructions and electric vehicle owner's manual that came with the charging pile.

2.1.3 Warning of gas accumulation

Because toxic or explosive gases can be released when charging indoors, some electric vehicles require an external ventilation system. Check your vehicle's owner's manual to check if it emits toxic or explosive gases while charging.

2.2 Installation condition

- Calculate existing electrical loads to determine the maximum operating current.
- Calculate the distance from the power panel to the charging station installation to ensure minimal voltage drop. (Varies by region or country's local regulations)
- Obtain any permits you feel necessary from the competent local authority and confirm that a follow-up inspection has been arranged by an electrician after the installation has been completed.
- The PE ground connector must not be spliced.
- Select conductor size according to local regulations, maximum current and maximum voltage drop.
- Use the right tools and ensure adequate material resources and protective measures are available.
- Make sure the area where the charging post will be installed has good cellular reception.
- Install the correct power and data cables in the installation area.
- Since the vent of the charging pile is located at the back of the charging pile, the free space behind it must be ventilated accordingly.
- If used indoors, the ventilation of the room must exceed 3000 cubic meters/hour.

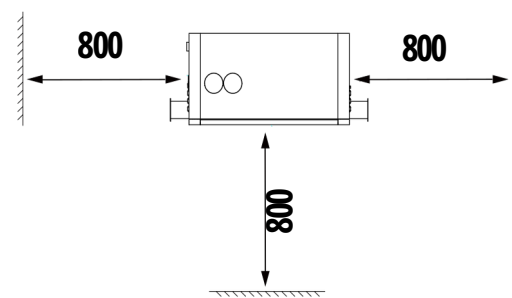

2.3 Handling packing boxes

(1) Use a forklift to move the packaged products

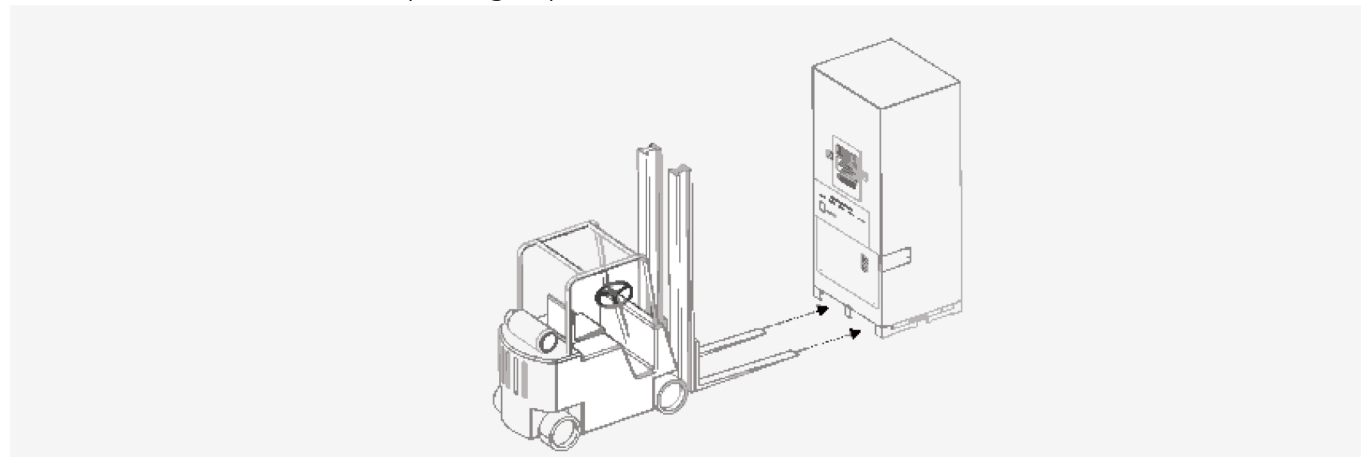

2.4 Unpack

(1) Remove the two sides and back boards

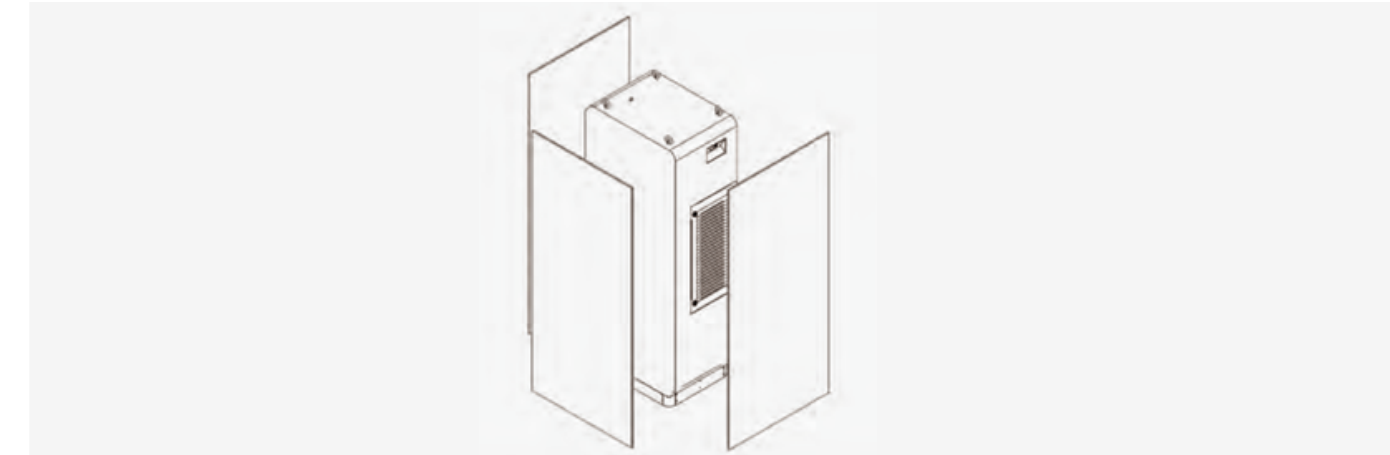

(2) Remove the front board



(3) Take off the top of the wooden box

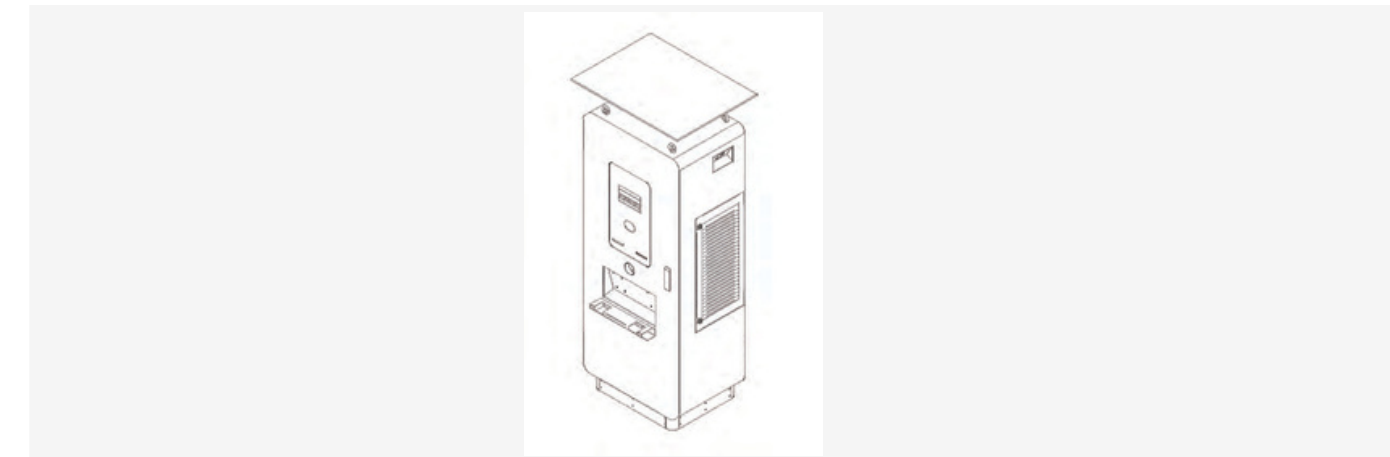

(2) Remove the front board

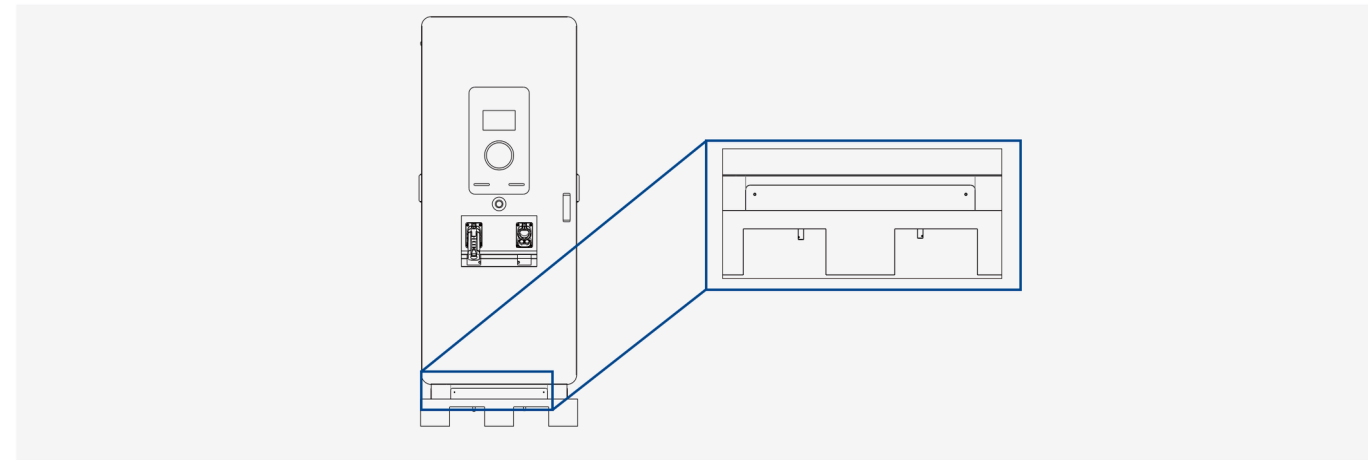

2.5 Handling charging piles

2.5.1 Handling by forklift truck

Charging piles can be transported with forklifts



2.5.2 Handling by crane

The charging pile can be operated with a crane; Four mounting holes for lifting rings are reserved at the top. (1) Tighten 4 lifting rings

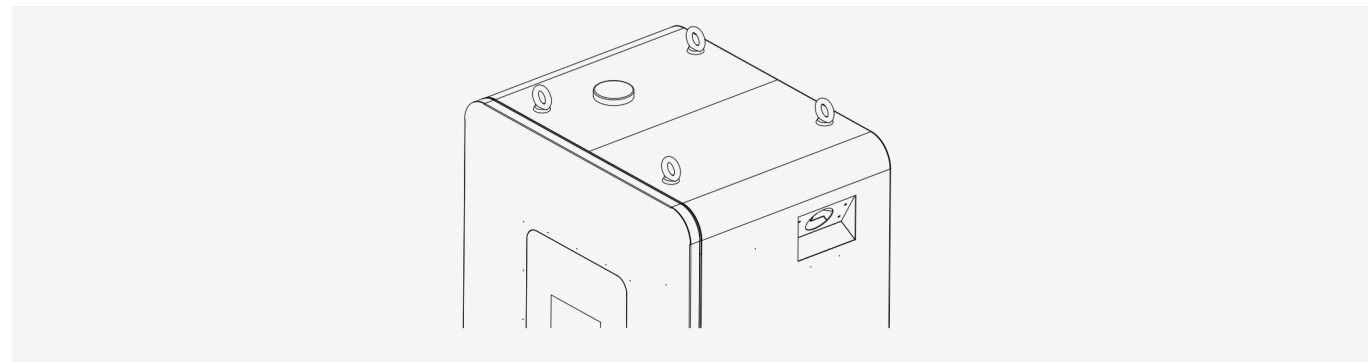

(2) Install hooks and slings

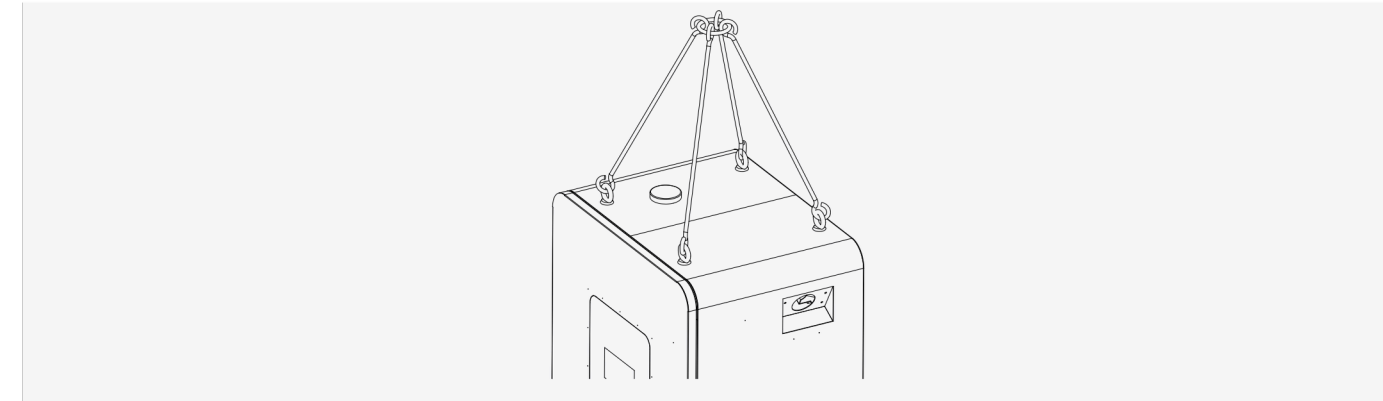

2.6 Requirements for concrete foundation fabrication

2.6.1 Condition

- Please comply with the following regulations regarding foundation
- Construction of foundations must be carried out in accordance with local regulations.
- The characteristics of the concrete need to be calculated based on the technical data of the charging station.
- Concrete should be winterized.
- It is necessary to calculate the foundation thickness and select the installation site according to the weight of the whole pile system. The foundation must be level.
- Tilting left-right or front-back can cause water seepage and damage the charging station.
- The foundation must be under the ground.
- Charging piles must be installed on the ground.

2.6.2 Construction drawing of concrete foundation

(1) The strength grade of concrete is not lower than C20, the underground part is 40cm, the above-ground part is 20cm, and the concrete dimensions are length * width * height of 800*700*400mm; Complete appearance, flat, no cracks; The outer contour at the bottom of the equipment is 600*500mm. After the equipment is installed, the distance between the four edges of the equipment and the four edges of the foundation is 100mm.

(2) The embedded pipeline of the foundation should conform to the opening position of the bottom plate of the charging pile to avoid the inconsistency between the pipeline and the opening and the inability to construct.

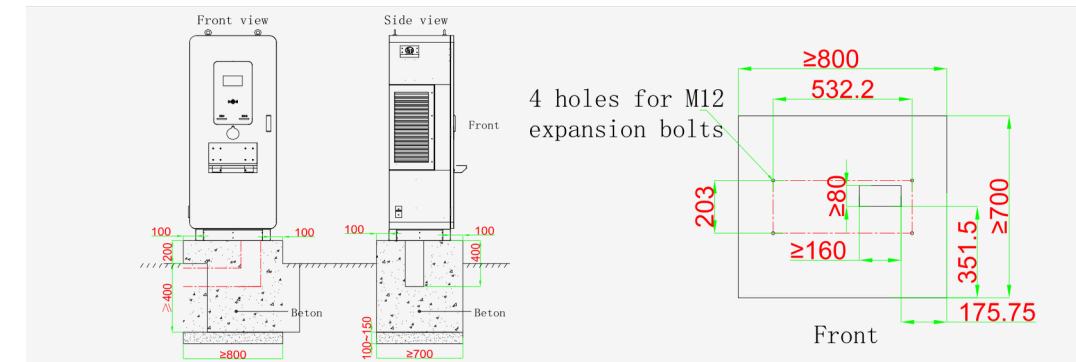

(3) The installation shall be fixed with $\phi 12$ embedded parts or expansion bolts, made of stainless steel or hot-dip galvanized material

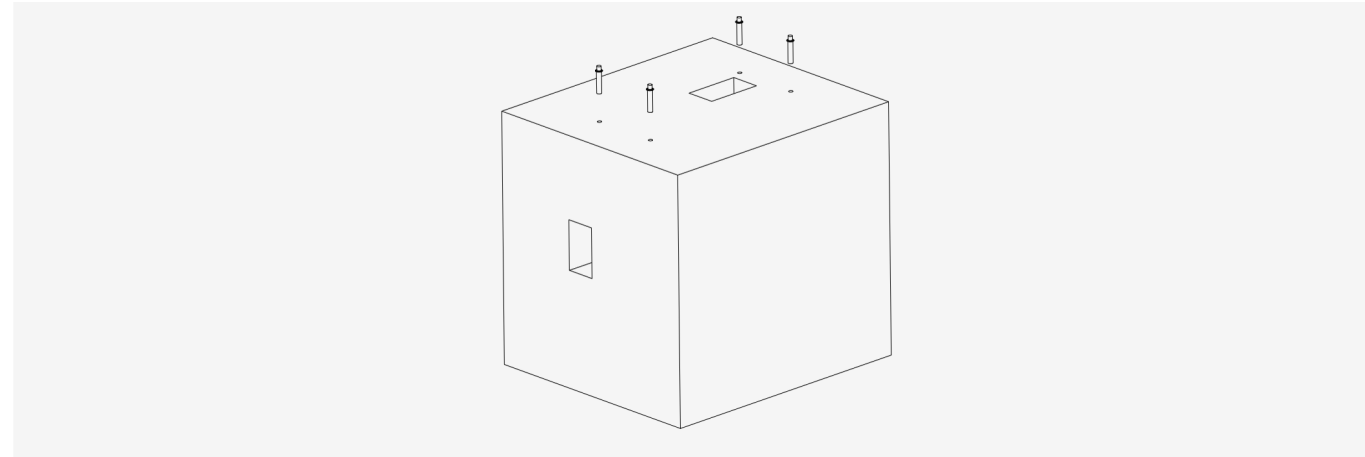

2.7 Installing chargers

The fixed hole position of the charging pile is aligned with the opening hole of the foundation, and locked with M12 expansion screw

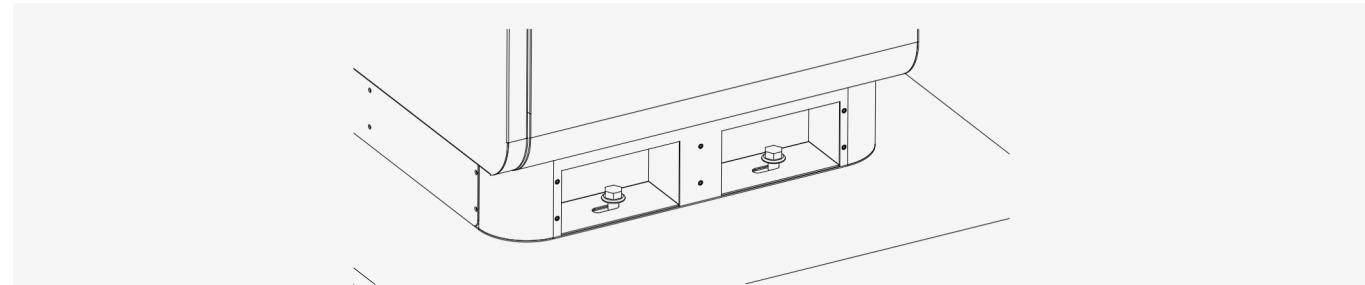

2.8 Cable Access

The connection form of the live conductor system of this product is three-phase four-wire system, and the grounding form of the low-voltage distribution system can adopt TT system and TN system. The following recommended system grounding indications are TN-S system or TN-C-S system.

Connect the three-phase cable embedded in the pile foundation to the input end of the pile. Pay attention to the connection method of the five wires and the corresponding colors. Connect the ground wire to the grounding bar of the cabinet, as shown in the figure below. After the cable is connected, the cable inlet should be sealed with fireproof mud.

Note: Refer to the table below for the cable diameters of the AC input (L1, L2, L3, N, PE):

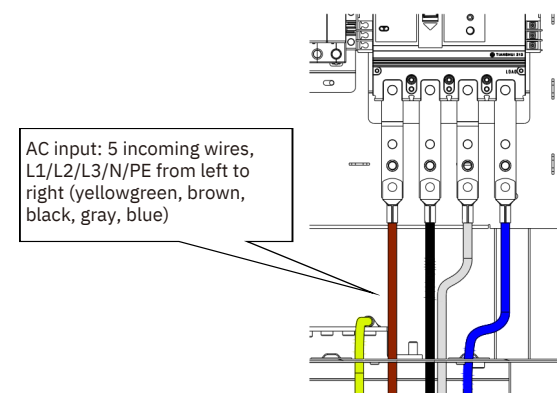

Input cable selection reference table [GB/T12706.1(IEC60502-1)]

*Please follow IEC 60364 or local laws and regulations for on-site conditions

Product model	Recommended incoming cable (not less than)	Material	Recommended terminal blocks
BXC60-S	YJV3*35mm ² +2*16mm ²	Red copper	DT-35/DT-16
BXC60-D			
BXC90-S	YJV3*50mm ² +2*25mm ²	Red copper	DT-50/DT-25
BXC90-D			
BXC120-S	YJV3*70mm ² +2*35mm ²	Red copper	DT-70/DT-35
BXC120-D			

Grounding requirements for Charging station equipment:

1. Location: Lower left corner on the side of the device
2. Grounding resistance requirements: The grounding resistance of charging station equipment should generally not exceed 4Ω, and should be kept within the required range throughout the service life of the charging station.
3. Grounding method: When using metal rods for grounding, the metal rods should be buried underground at least 1.5 m to ensure the firmness of grounding. According to local soil properties and climatic conditions, the gold needs to be increased Belongs to the depth of the rod position.
4. Grounding point selection:
 - (1) The ground point should be close to the charging station to ensure that current can flow back to the ground wire.
 - (2) The grounding point should be far away from industrial noise and interference sources to avoid affecting the grounding quality.
 - (3) The grounding point should avoid obstacles such as cement pavement to prevent the grounding impedance from being too high.
5. Grounding cable: Use at least 25 mm² cable

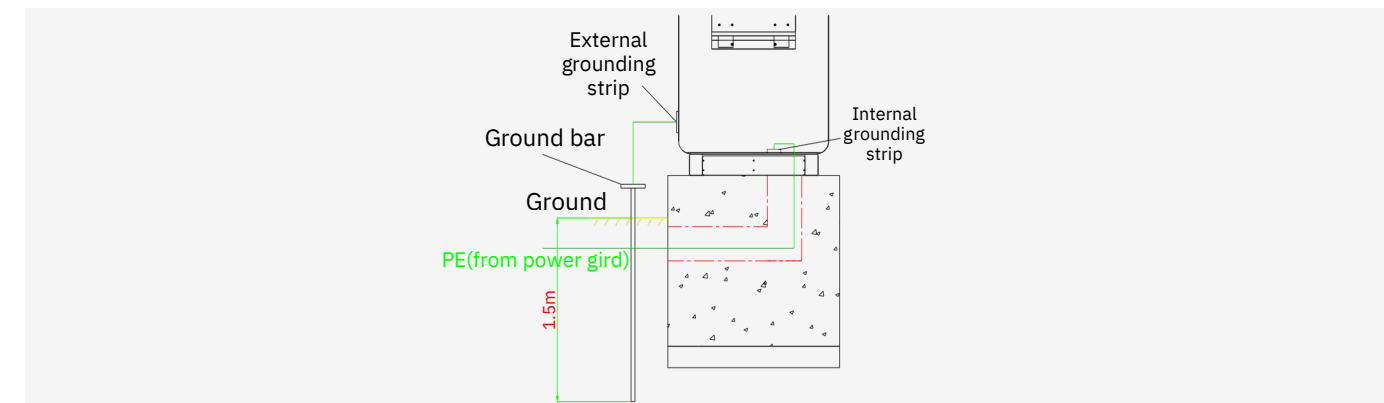

2.9 Network Options

Pictures	Configuration	Remark
	<ul style="list-style-type: none"> • Ethernet: LAN (OCPP) • 3G/4G: SIM card • WiFi: 2.4GHz 	Network cable length not exceeding 30m Rj45 interface and Cat5e cable

2.10 Connecting the OCPP Platform

2.10.1 Information Required Before an Operation:

- OCPP server address.
- Address remote(port)

2.10.2 Network connectivity

(1) When the charger is in standby state, press the emergency stop switch on the side of the cabinet

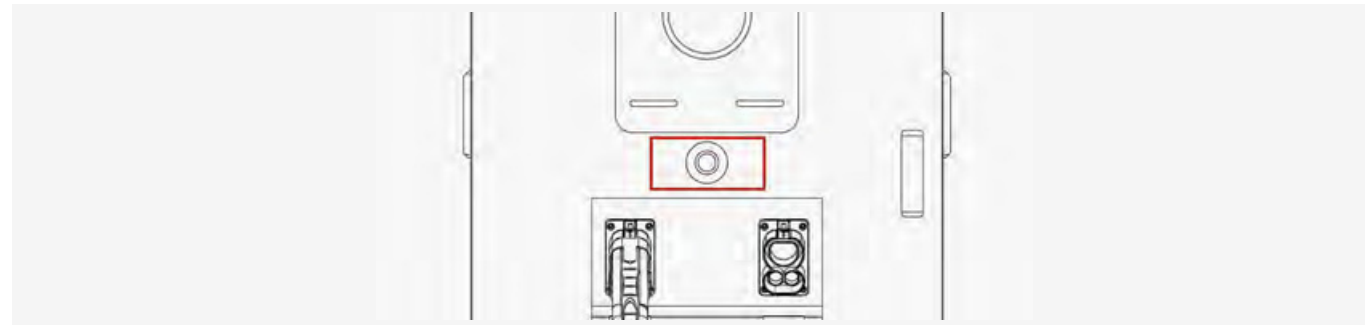

(2) Click on any charging gun icon five times, and when you hear the beep of "Didi", wait to enter the login interface

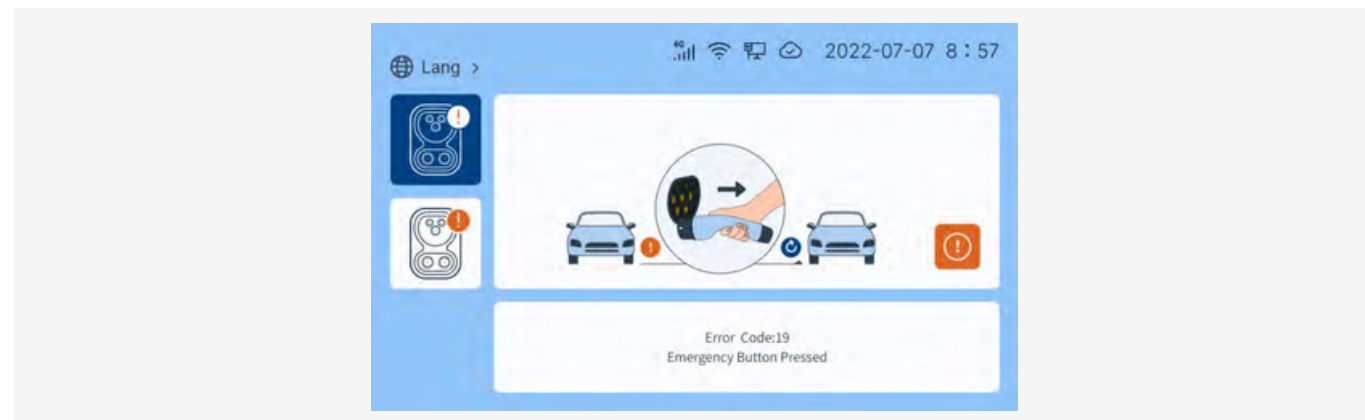

(3) Enter the password in the login interface. The default password is 12345678

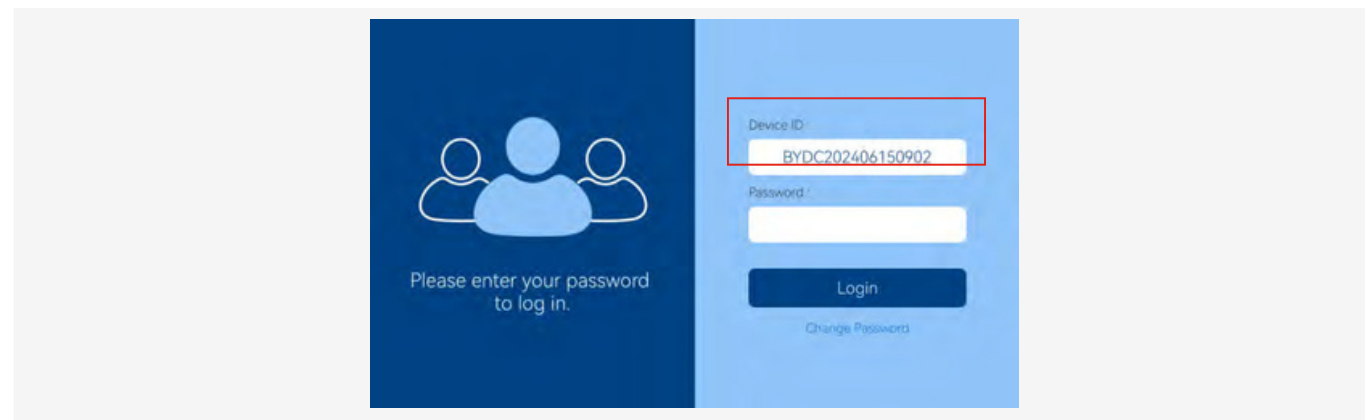

(4) Configure the network, check the required mode, and click the arrow in the lower right corner to proceed to the next step

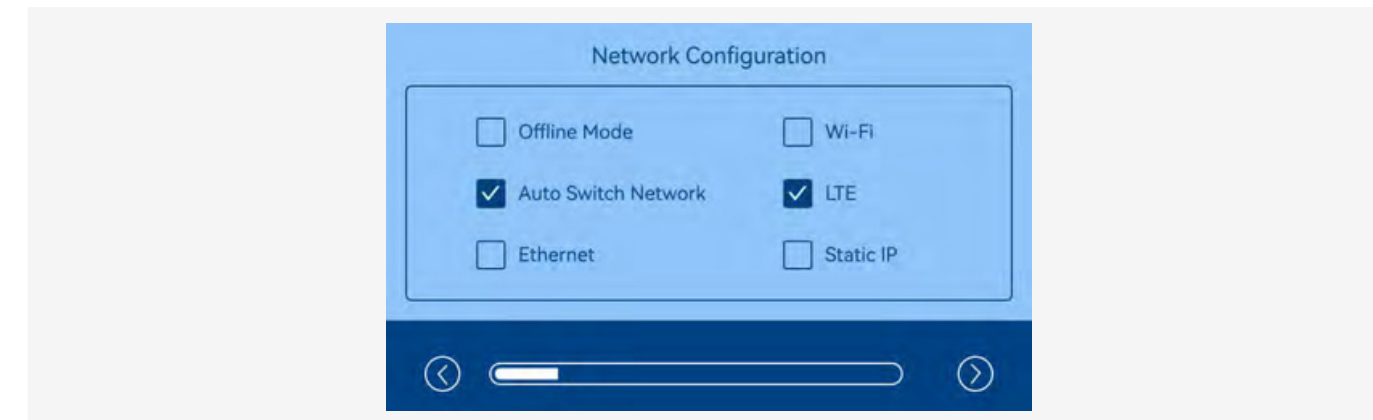

- Offline mode: Local charging mode, no billing settlement is performed.
- Wi-Fi: The device is connected to the wireless network for network billing and settlement.
- Automatic network switching: When two or more networking modes are configured, the system will automatically switch networks according to the network status.
- LTE: Devices perform networked billing and settlement through 3G/4G.
- Ethernet: The device is connected to Ethernet for network billing and settlement.
- Static IP: Set a fixed IP address. When the device connects to the network, it will no longer automatically obtain the network address.

(5) Configure WiFi, enter WiFi name and password.

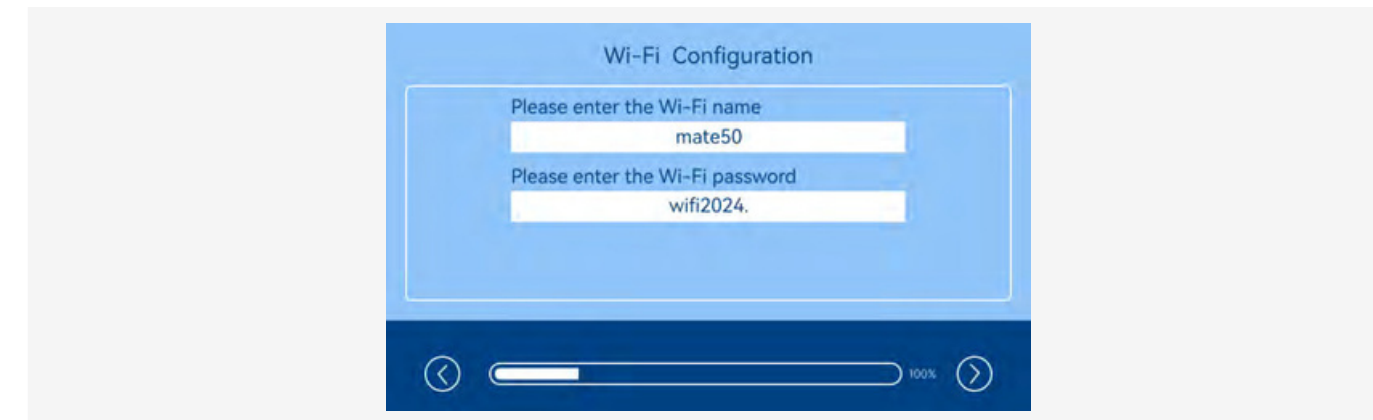

(6) Configure LTE APN, and if there is a configuration requirement, enter the authorized information; If there is no configuration requirement, go directly to the next step

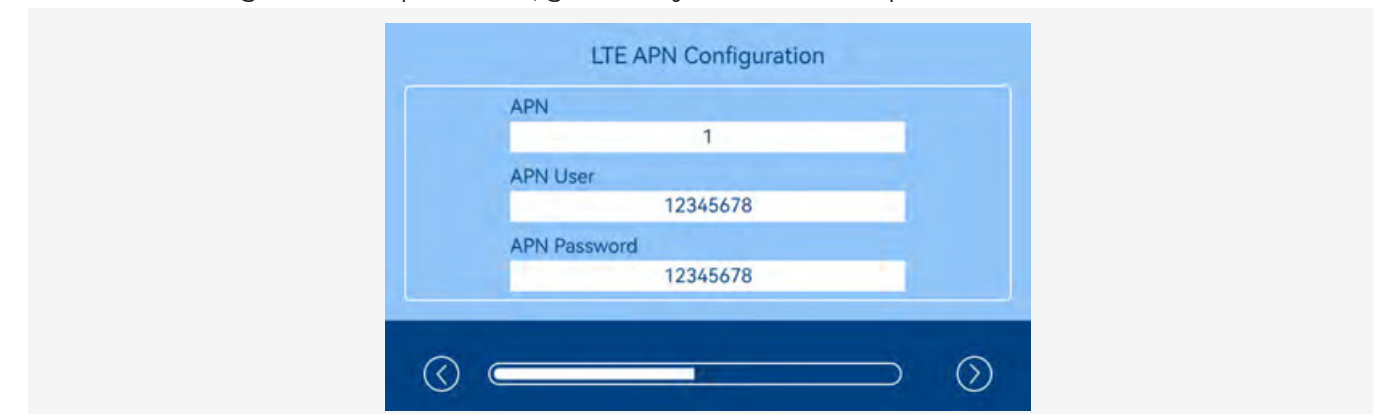

(7) Configure static IP, enter static IP, gateway, subnet mask

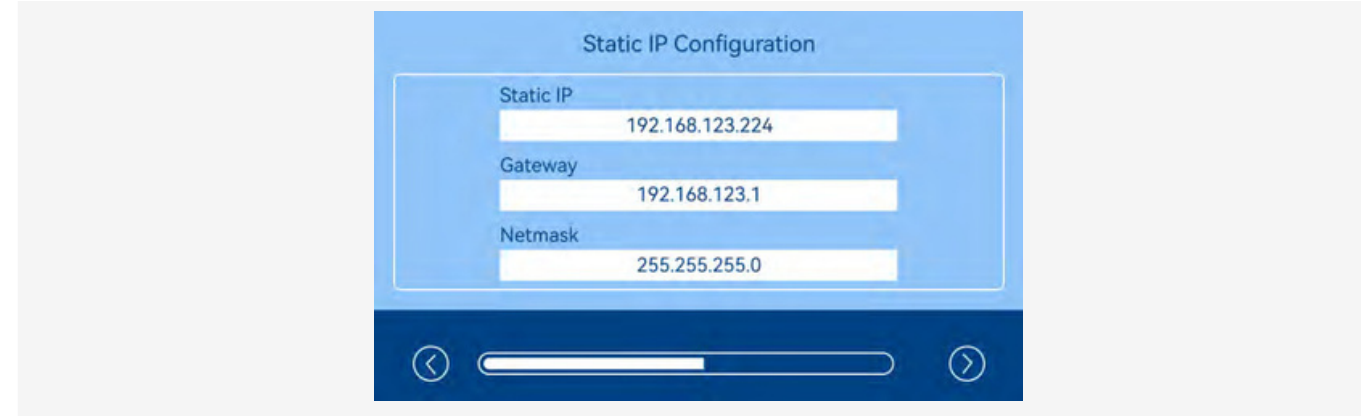

(8) To configure OCPP, enter the URL address

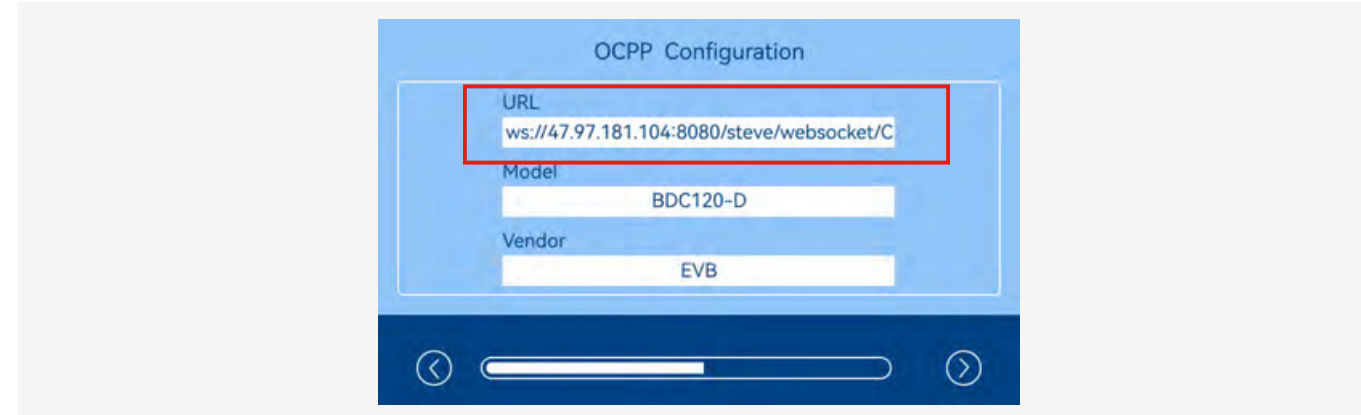

(9) Click the arrow in the lower right corner to complete the configuration and reset the emergency stop switch in time

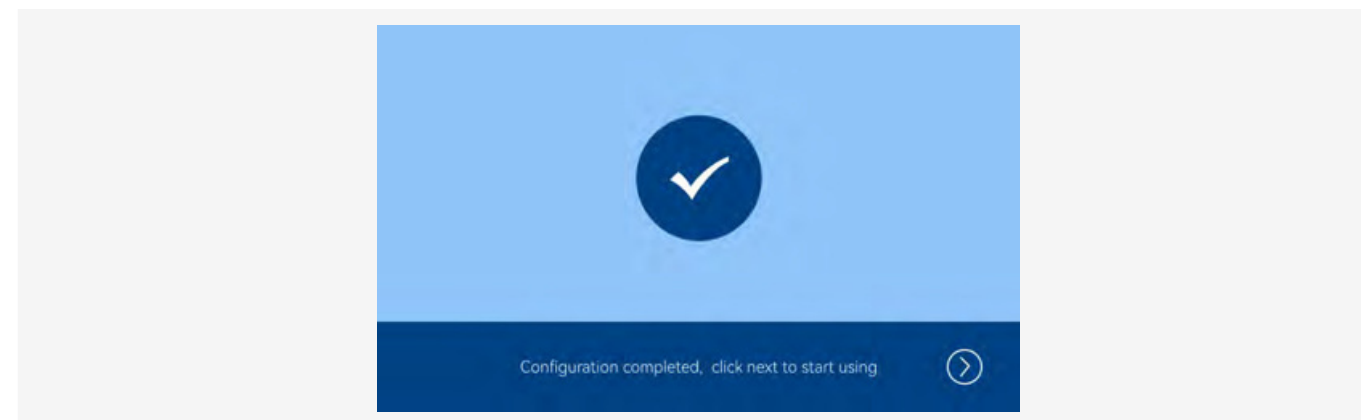

2.11 Charger installation acceptance

1. Visually check the shell of the charging device should be flat, without obvious dents, scratches, deformation and other defects; The surface coating should be uniform, without falling off; The parts should be tight and reliable, without corrosion, burr, crack and other defects and damage.
2. The basic construction and electrical installation of the charging equipment shall comply with the requirements of the design drawings and installation instructions.
3. The charging device should be firmly installed, all expansion bolts should be locked, and the torque should not be less than 12.4N·m. Layout Reserve enough space for device maintenance and repair. Install devices at a height that ensures easy man-machine interaction.
4. The models and specifications of the power supply cables should meet the requirements. The cables should be neatly arranged, firmly bound, and clearly marked when laying, and the length of the connection points should be left with appropriate allowances.
5. Before powering on the device, check whether the device is securely grounded. The grounding resistance should not exceed 4Ω.
6. Check whether the cable trench is reliably sealed with fireproof mud.

3. Operation instructions and precautions

3.1 Pre-use safety check

- Ensure that the product is not scratched, rusted, deformed, etc.
- Ensure that the power supply socket is safe and that there is no foreign matter left in the charging plug and the charging socket at the vehicle end.
- If the charging cable or charging gun tip has problems such as damaged shell or exposed cable, please do not continue to use it.
- Keep the charging gun plug dry. If there is accumulated water, please dry the water of the charging plug with a dry and clean cloth when the whole pile body is powered off.

3.2 Operational precautions

- If the screen shows that the machine is malfunctioning, please do not charge, please contact the staff;
- Confirm that the IC card balance is sufficient when swiping the card. If the balance is insufficient during the charging process, the charging will be automatically terminated;
- When two charging interfaces are used at the same time, the user should carefully identify whether he is user A or user B during the card swiping process, and swipe the card according to the operation prompts of the interface to avoid misoperation;
- Please follow the relevant prompts of the charging equipment when operating; Pay attention to the strength when plugging and unplugging the charging gun, and don't use too much force;
- During the card swiping operation, the "beep" prompt sound that needs to be heard can only be removed, otherwise the operation may fail; When the charging gun is inserted into the interface and the green indicator light above lights up, it means that it has been powered on. Please do not unplug and unplug the charging gun at this time to prevent electric shock;
- When an emergency occurs, please press the emergency stop switch. Charging cannot be performed at this time. If charging is in progress, charging will stop immediately;
- During use, you should always check the small firing pin or indication window on the lightning protector (as shown in the figure below).
- If the firing pin protrudes or the window turns red, it means that the lightning protector has been damaged and should be replaced immediately.

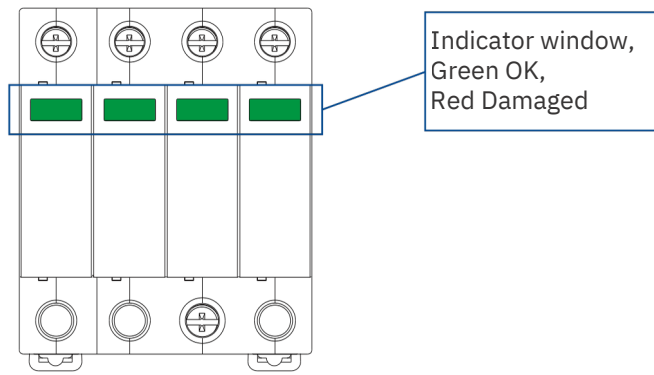

Figure 3—1 AC lightning protector

3.3 Language selection

(1) Click the Lang icon in the upper left corner of the interface to enter the language selection interface



(2) Select the language, click the flag icon corresponding to the required language, and you can select two languages for display



3.4 Charging status description

(1) Insert the standby charging gun on the charging pile into the charging port of the car body, providing four charging methods: card charging, MAC charging, QR code charging, and POS machine charging (If equipped); Select a desired payment method and verify it.

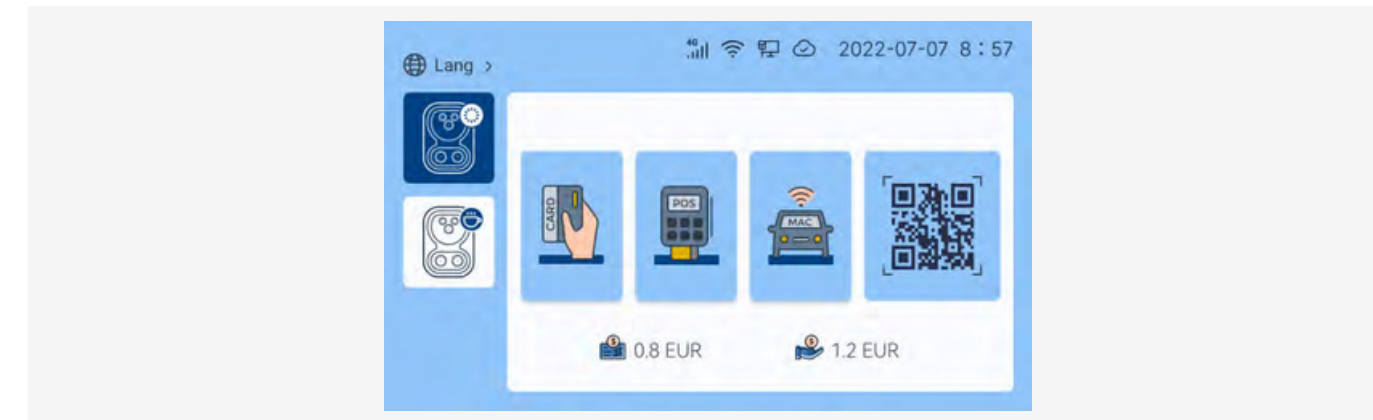

(2) If you choose to charge by swiping card, please place the charging card in the swiping area and wait for the card information to be verified



(3) If you select POS machine charging, please verify the operation according to the prompts on the POS machine

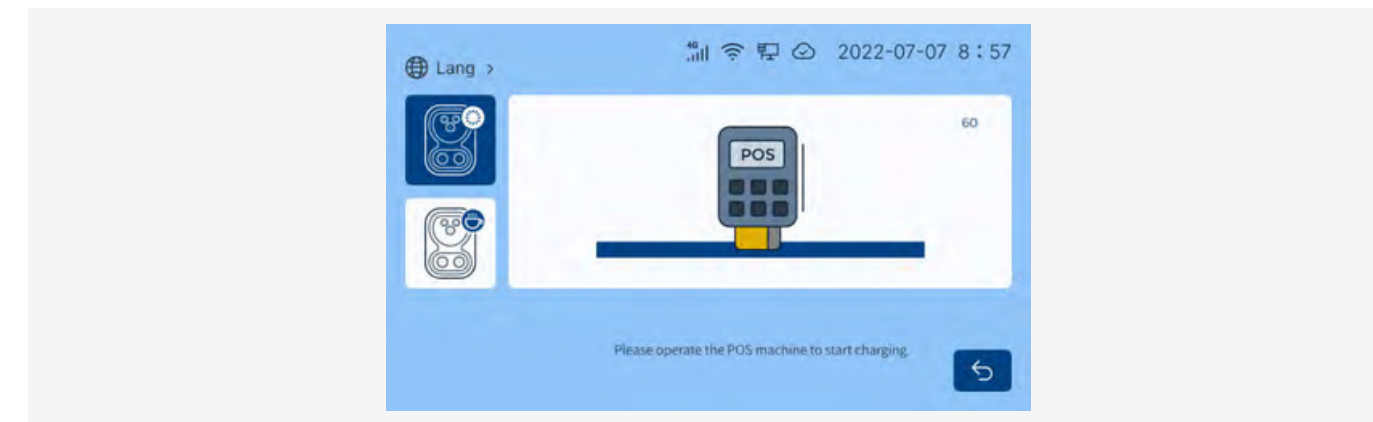

(4) Verification completed, charging is starting, please wait patiently for the device to start

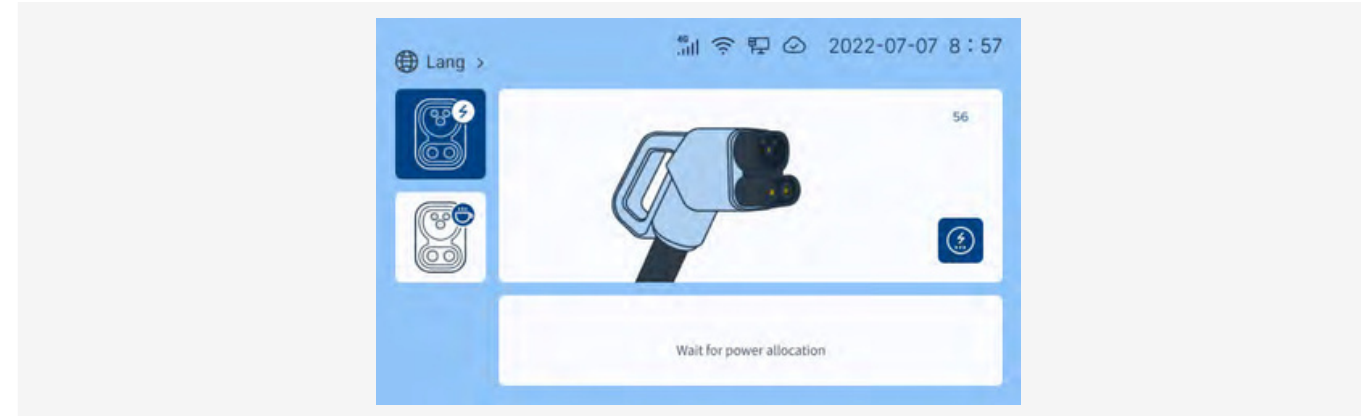

(5) During charging, the screen displays the charging status, charging time, current output current and voltage, charging power, charging electric energy, vehicle requested current and voltage parameters



(6) Click STOP in the lower right corner of the interface to enter the charging end verification stage

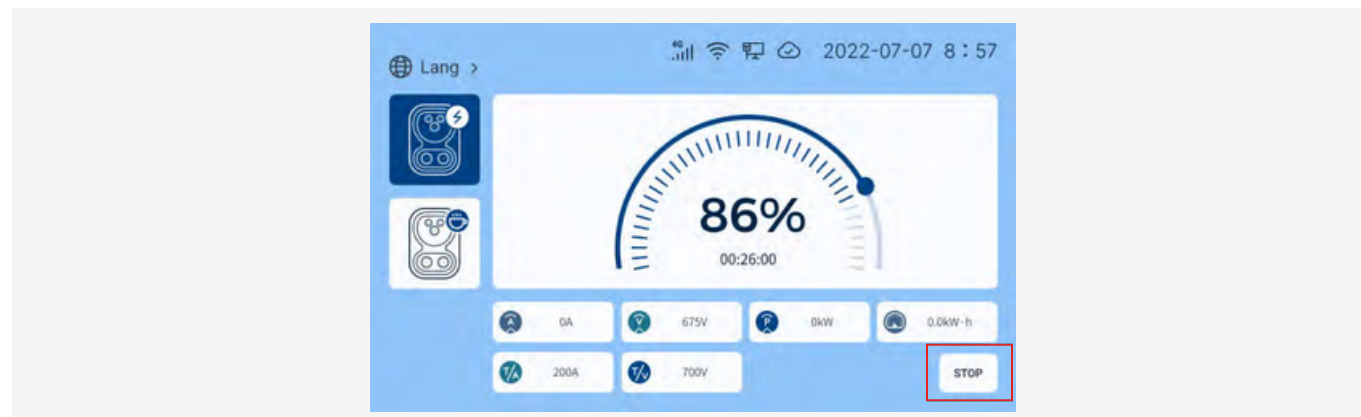

(7) Put the charging card in the card swiping area, confirm that charging is stopped and charging settlement is carried out

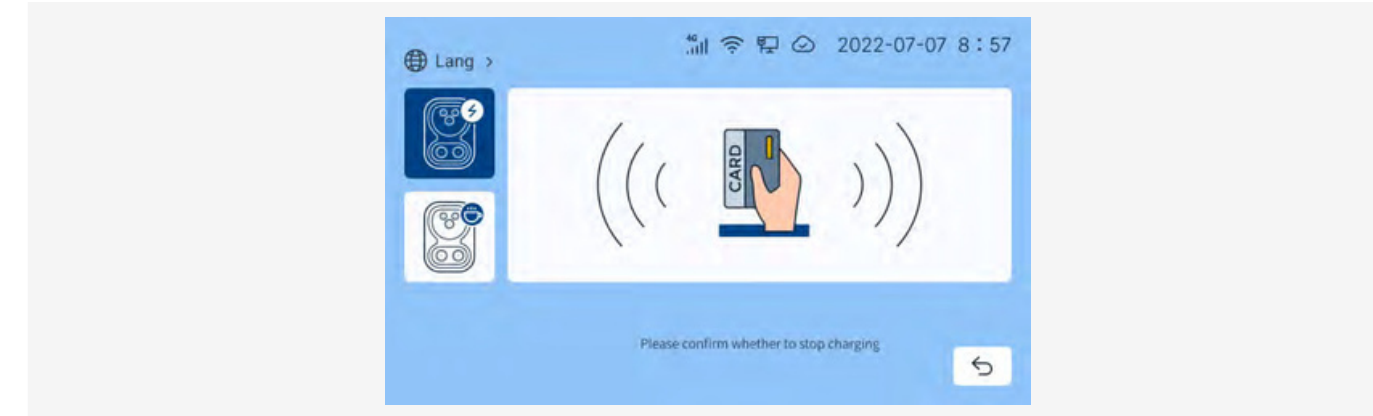

(8) Charging is being terminated

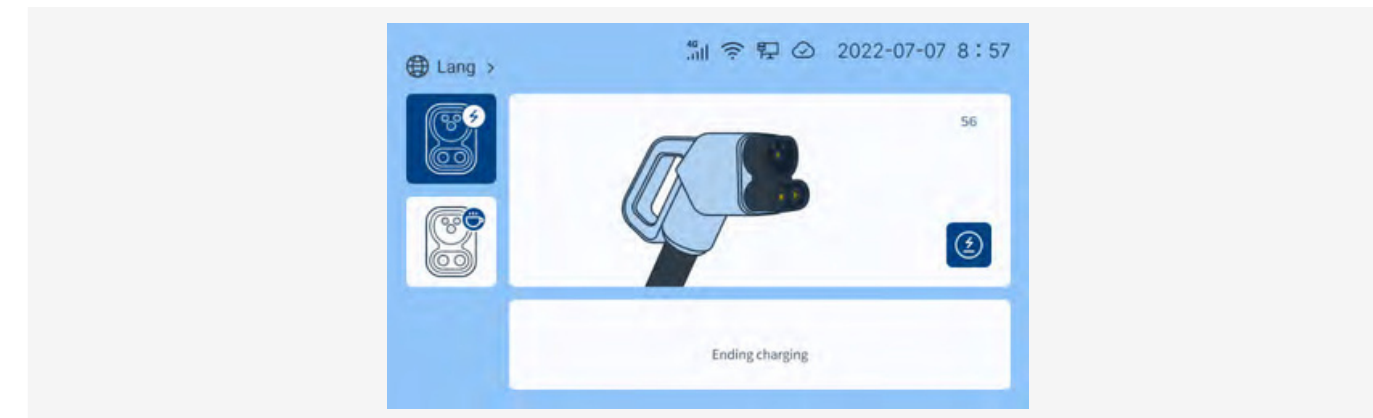

(9) The charging has been completed, please return the charging gun to its position

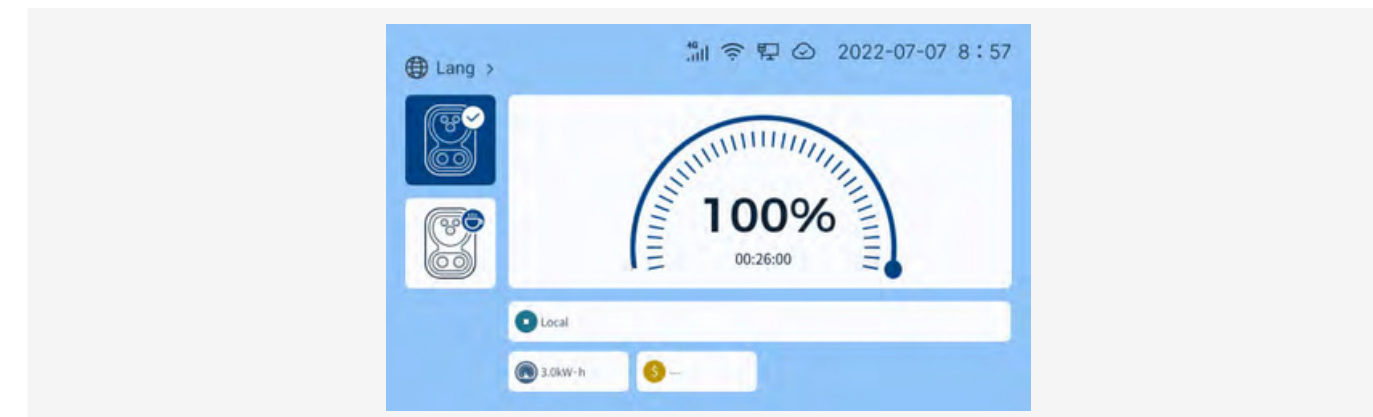

3.5 Indicator lamp description

There are ten indicator states above the device:

- Normal standby state: The green light is on.
- The charging gun is inserted into the charging port: The green light is flashing.
- Charging in progress: The green flowing light is on.
- The charger is paused: The middle of the green light is on while the two sides are dim, or the yellow flowing light moves from left to right.
- The EV battery is fully charged: The two sides of the green light are on while the middle is dim, or the yellow flowing light moves from right to left.
- Charging completed: The green light or the yellow light is on.
- The charger is reserved: The green light or the yellow light is flashing.
- The charger is unavailable: The red light is flashing.
- The charger is malfunctioning: The red light is on.
- The light panel is offline: The red light flashes from left to right, or the yellow light flashes from left to right.

3.6 Instructions for use of emergency stop switch

- If the machine leaks electricity, press the emergency stop switch immediately.
- In case of fire, electric shock and other abnormal conditions, please press the emergency stop switch immediately.
- If the pile fails, if the charging cannot be stopped, the internal circuit is short-circuited, etc., please press the emergency stop switch immediately.
- When the emergency stop switch is pressed in the non-charging state, the fault light will come on and the LCD screen can enter the configuration interface.
- When the emergency situation is relieved, please reset the emergency stop switch, otherwise the charging cannot continue.

3.7 Charging system host computer software description

Note: The host computer software is provided to customers when there are special needs. Please do not change the configuration of the charging pile at will. All problems caused by arbitrary changes by human beings shall be borne by the customer. See the technical guidance documents for software and operation instructions.

The software interface of the host computer is shown in the following figure:

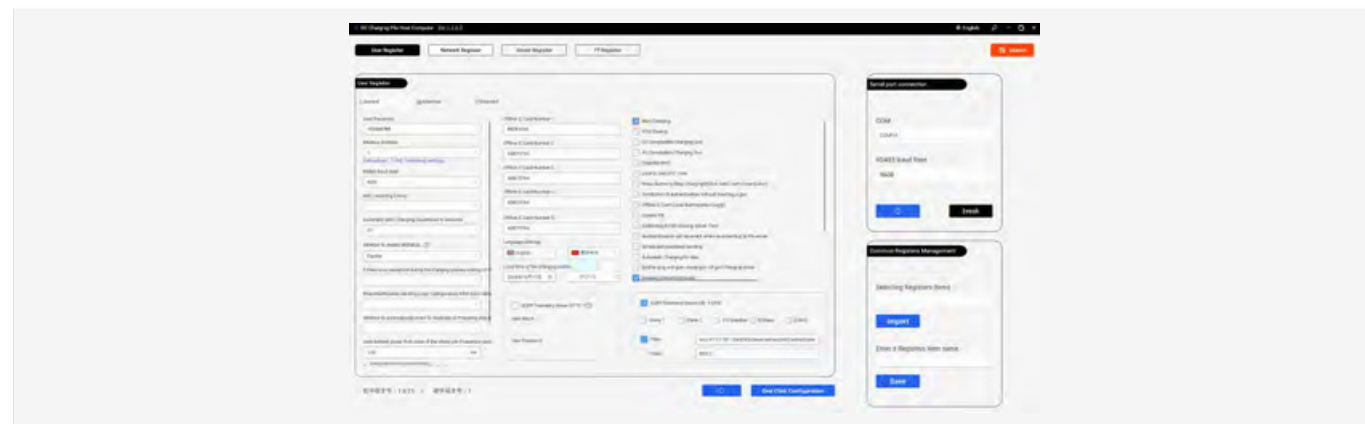

The communication connection points between the host computer and the main control board are J8 area: RS485-4-A and RS485-4-B. The wiring point is at terminal XT11.

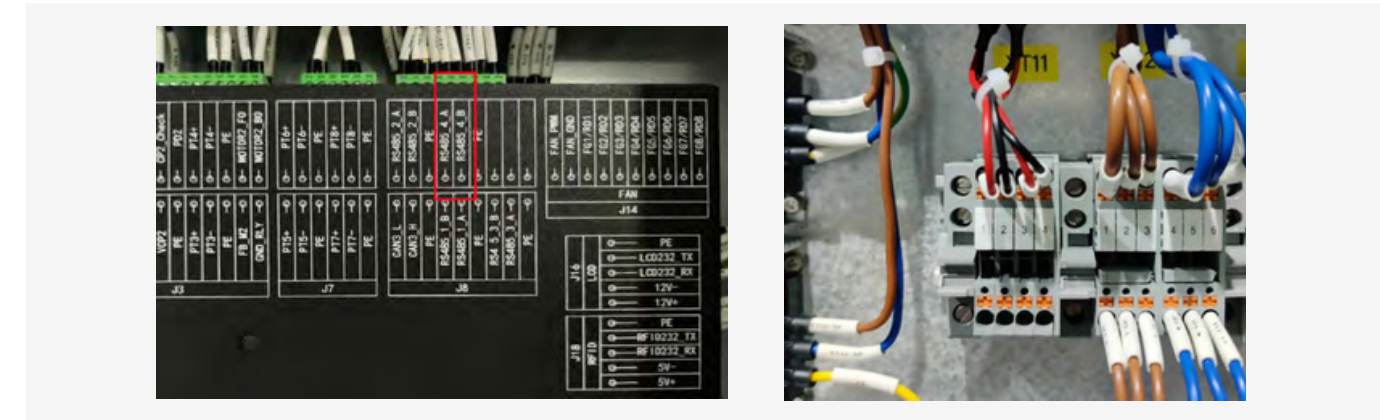

4. Packaging, Shipping and Storage

- Packaging: The pile body is tied tightly with brushed film for protection, surrounded by foam support and protection, and packaged with wooden box.
- Transportation: The product should not be violently shocked, impacted and inverted during transportation, so as not to damage the product.
- Storage: If the product needs to be stored after purchase, it must be placed in a dry and ventilated indoor place, and cannot be turned upside down.

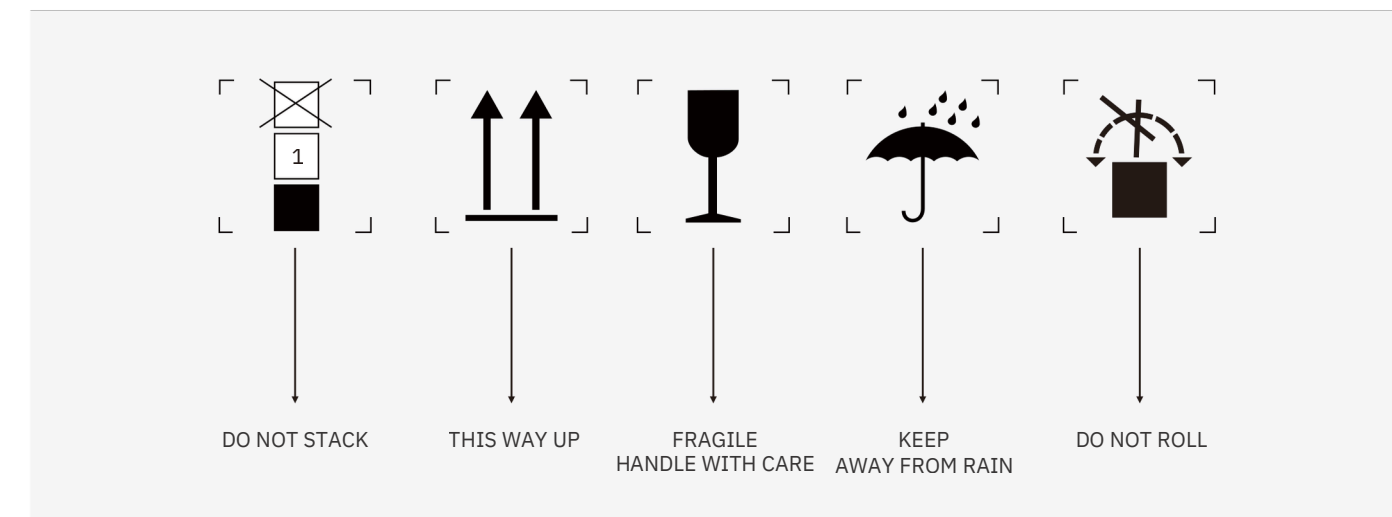

5. Ordering instructions and after-sales service

5.1 Ordering instructions

- Must understand the application and scenario of the equipment, and fill in the customer demand form.
- Provide product name, model, specifications, parameters, and configuration requirements when ordering;
- When the user has special environment or technical requirements for the equipment, please negotiate with the technical personnel of the factory and sign an agreement.

5.2 After sales service

Under the conditions of custody, installation, use and operation by the user, the shelf life of the product is set out in the commercial contract.

If the product is damaged or cannot be used normally due to poor manufacturing quality, the production unit is responsible for repairing, debugging or replacing parts for the user free of charge.

5.3 List of Attachments

- Accessories: 5 expansion screws for installation, 1 USB conversion cable, 4 IC cards
- Technical documents: instruction manual, certificate of conformity, warranty card, factory inspection report

5.4 Nameplate

Nameplate

Instructions

Input Voltage	Rated Frequency
Operating Temperature	Rated Input Current
Protection Level	Protective Class
Serial Number	Date
Connector Type	
Rated Power	
Output Voltage	
Max Output Current	

Appendix

Appendix I Fault Information Table (see attachment controller fault list code and handling method)

Fault Code			
Fault code	Fault description	Analysis of Causes	Handling
0	Input AC Contactor Adhesion	inspection	1. Reset the charger to check whether the fault is repaired. 2. If the fault is not restored, check whether the contactor is damaged and replace and repair the contactor.
1	Input AC Contactor Fault		
2	Output Contactor Adhesion		
3	Output Contactor Fault		
4	Parallel Contactor Adhesion		
5	Parallel Contactor Fault		
6	DC OverCurrent	Restart charging	
7	Battery Reverse	1. Re-insert the gun to start charging. 2. Repair	1. Check if the battery module is normal. 2. If there is no response, replace the power module.
8	Fuse Fault	inspection	1. Check if the fuse is damaged. 2. Replace the fuse.
9	DC Meter Offline	inspection	1. Re-energize the charger and check whether the fault is restored. 2. If the fault is not restored, check whether the line is loose or damaged. 3. Check whether the meter is on. If not, replace the meter.
10	SECC CAN Offline	inspection	1. Check if the SECC CAN wiring is loose and if the indicator light is on. If it is on, please repower the charger. 2. If the indicator light is not on or the indicator light is on, the wiring is intact, and the fault is not repaired after repowering, please replace the SECC CAN.
11	Insulation Monitoring UnderVoltage	Ac input contactor mistaking action or rejecting action	Replacing the insulation monitoring device
12	Insulation Monitoring Alarm	K1K2 gets in touch with mistaking action and rejecting action	
13	Insulation Monitoring Over	The charge in the BSM packet stops after 10 minutes	
14	Reserved fault bit		
15	Insulation Monitoring Run ACDC Fail	1. Restart charging. 2. If the fault is not resolved after several attempts, repair it.	Replacing the insulation monitoring device

16	Insulation Monitoring Overtime	1. Restart charging. 2. If the fault is not resolved after several attempts, repair it.	Replacing the insulation monitoring device
17	Insulation Monitoring Offline		
18	Fan Fault	inspection	Check whether the fan communication line is loose: Check whether the fan control terminal on the motherboard is properly plugged in.
19	Emergency Stop Pushed	inspection	1. Check whether the emergency stop button is pressed. If it is pressed, lift the button. 2. If the button is lifted and the fault is not restored, the emergency stop button is considered damaged and should be replaced or repaired.
20	Door Open	inspection	1. Check whether the charger door is opened. 2. Check whether the sensor on the charger door is damaged and replace it.
21	Surge Fault	inspection	Replace the surge protector
22	Water Immersion Error	inspection	1. Check if the charger has water ingress. 2. If no water ingress occurs, check if the water sensor is faulty and replace it to repair it.
23	Dumping Error	inspection	1. Check whether the charger body has tipped over. If so, correct it. 2. If not, replace the tipping detector.
24	Smog Error	inspection	1. Check whether there is smoke around the charger. If there is, please investigate the cause and solve the problem. 2. If there is no smoke around, please check whether the smoke alarm is damaged. If it is damaged, please replace or repair it.
25	BEM related failures	There are many BEM-related faults, which are not listed here	
26	Stop BSM	Re-plug the gun to start charging	
27	DC Meter Error	1. Reset the charger and restart. 2. Repair	1. Check if the DC meter is working. 2. If it is not working, please replace the meter.
28	DC OverTemp EVSE	1. Re-insert the gun to start charging. 2. Wait for the temperature to drop and then reset.	1. Check whether the temperature sensor is working and whether the temperature is too high. 2. If the temperature is normal and the fault has not been restored, replace the temperature sensor.
29	DC OverTemp Connector	3. Repair	
30	AC Input OverVoltage	1. Check whether the requested voltage is less than the actual voltage (the requested voltage must be greater than or equal to the actual voltage). 2. Re-insert the gun to charge.	

31	AC Input UnderVoltage	1. Check whether the actual voltage is lower than the minimum voltage supported by the charger (the actual voltage should be higher than the minimum voltage supported by the charger). 2. Re-plug the charging gun to charge.	
32	ACDC Module Offline	inspection	1. Check if the communication line of the power module is loose. 2. If not, replace the power module.
33	ACDC Module Error	inspection	1. Check if the communication line of the power module is loose. 2. If not, replace the power module.
34	Humidity High Error	1. Reset the charger. 2. Repair	1. Check whether the humidity of the charger is normal. 2. If the humidity does not exceed the normal humidity, please replace the humidity monitor.
35	BHM Overtime	Re-plug the gun to start charging	
36	BRM Overtime		
37	BCP Overtime		
38	BRO Overtime		
39	BCS Overtime		
40	BCL Overtime		
41	BSM Overtime		
42	BST Overtime		
43	BSD Overtime		
44	MCCB Fault	inspection	1. Check whether the molded case circuit breaker is tripped. If it is tripped, reset it. 2. If the reset fault is not restored, consider that the device is damaged and replace it for repair.
45	PT1000 Data Error	inspection	1. Check whether the temperature sensors of the charger body and the gun line are intact and whether the wiring is loose. 2. If there is no fault, please replace the temperature sensor.
46	No PE detected		1. Check if the PE connection is loose. 2. If it is not loose and the fault exists, please replace the control main board.
47	DLB Offline	inspection	1. Check if the DLB wiring is loose. 2. If it is not loose and the fault exists, replace the DLB.

Appendix II Electrical Schematic Diagram

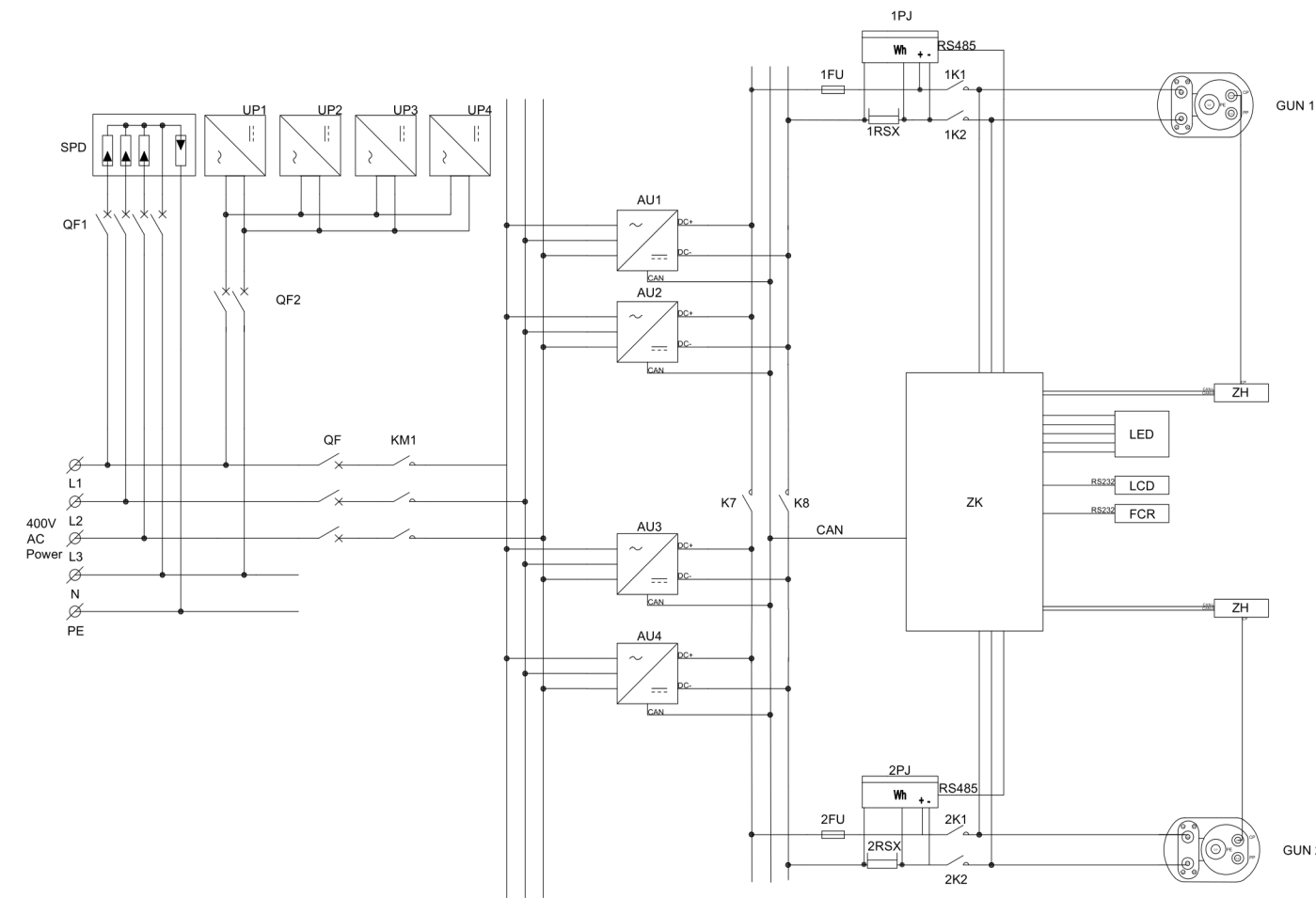

Appendix III Charging pile equipment maintenance guide

1. Maintenance personnel requirements:

- Have relevant certificates and qualification certificates
- Familiar with the basic working principle and use method of charging equipment, basic maintenance methods and requirements
- Familiar with emergency handling and simple troubleshooting methods of charging equipment

2. Refer to the following table for the contents and periods of safety check and maintenance, and make records

Charging equipment safety inspection and maintenance content, cycle		
No.	Examination content	Maintenance intervals
1	The protective shell of the charging device has no scratches or rust, and the base bolts are firmly fixed	Once a month
2	The external warning and indication signs of the charging equipment are complete and clear	
3	Charging equipment door lock opening and closing function is good, door seal strip, antenna glue intact, no leakage phenomenon	
4	No damage to the gun head of the charging connection device, no scratches and cracks in the cable	
5	The inside of the charging device is clean, and the components and cables have no burn marks	
6	Clean the dust and dirt on the surface of the charging device shell and the charging connection device	
7	Clean the heat dissipation hole and air filter of the charging device to ensure proper heat dissipation	Once half a year
8	Clean up the dust inside the charging device and ensure that the components are clean	
9	When the power is off, check that cables inside the device are securely connected, copper bar bolts are not loose, and insulation adhesives are not aging	Once a month
10	The input circuit breaker of the charging device can be on and off normally, and the leakage protection device can operate normally	
11	After the charging device is powered on, check that the human-machine interaction function of the device is intact, and the indicator light and screen display are normal, complete and clear	
12	Check that the cooling fan of the charging device runs normally and does not overheat during charging	once every three months
13	During the charging process, press the emergency stop button, and the charging device stops output immediately	

3. Charging facilities should be checked and maintained in the following special circumstances:

- Before and after extreme bad weather
- When the same fault occurs in a short period of time
- Charging station during trial operation

4. When defects of charging facilities are found in the operation and maintenance process, a fault sign should be hung in a prominent position, and the process of maintenance, scrapping and replacement should be arranged according to the defects.

Appendix IV Product warranty card

Thank you for choosing our products. This product has a warranty period from the commissioning date.

During the product warranty period, it is necessary to install and use according to the instruction manual. Under normal environment and conditions of use, due to the defects of raw materials and processing caused by the fault, you can enjoy free maintenance services according to the content of this warranty, this warranty card please keep properly as a warranty certificate, lost will not be reissued.

The following conditions will not be eligible for free warranty service:

- Damage caused by product installation and installation environment not conforming to product requirements, standards and related specifications
- The user's improper use of the product, improper storage or unauthorized dismantling, private maintenance and other reasons caused by the damage
- Damage caused by natural disasters (such as earthquakes, floods, lightning strikes), external disasters (such as fire, house subsidence), etc
- Failure or damage caused by the change of installation location, relocation, transportation, and improper storage
- Out of warranty

Note:

For products that exceed the warranty period or do not apply the warranty terms, the product will be inspected to determine whether to repair or replace the parts, and the repair and replacement of parts will be charged as appropriate

Warranty information sheet					
Product information	Manufacturer	BEXIE GROUP	Customer information	Name	
	Model			Contacts	
	Serial Number			contact way	
	Debug date			Address	
Warranty item				Signature:	
				Date:	
				Signature:	
			Date:		
			Signature:		
			Date:		



BEXIE GROUP

TYPE: BMDC60-D

bexiegroup.com

Input Voltage: AC 380~415V(3P+N+PE) Rated Frequency: 50/60Hz
Operating Temperature: -30°C~+50°C Rated Input Current: 102A
Protection Level: IP55 (screen IK08) Protective Class: Class I
Serial Number: BYDC202501161842 Date: 20250116

Connector Type	CCS2	GBT
Rated Power	60kW	60kW
Output Voltage	DC150V~1000V	DC150V~1000V
Max Output Current	DC200A	DC 200A

Working temperature: DANGER+high voltage Please don't open the cover
WARNING: Only for charging battery electric vehicles and plug-in hybrid electric vehicles
WARNING: Don't unplug or plug in the plug in the case of electricity

Bexie Group S.L.
Calle Covadonga 5, 33002 - Oviedo, Principado de Asturias (Spain)

