

Version: EN-UM-2.0



USER MANUAL

Three-phase ESS Inverter

HISTORY

VERSION	ISSUED	COMMENTS
1.0	11-Jan.-23	First release
1.1	27-Apr.-23	Updated expansion screws.
1.2	15-Jun.-23	Updated 3.1 Packing List , 7.1 LED and some details.
1.3	29-Jun.-23	Revised the description from hybrid inverter to ESS inverter.
1.4	05-Jul.-23	Updated the recommended battery brands.
1.5	13-Jul.-23	Adjusted “ Time-based Control ” from Chapter 5.1.3 to Chapter 7.2.3 .
1.6	11-Aug.-23	Updated circuit diagrams in 4. Electrical Connection . Adjusted 7. User Interface .
2.0	21-Dec.-23	Updated mounting bracket in 3. Installation . Updated circuit diagrams in 4. Electrical Connection . Updated 4.6.1 BMS connection and 4.6.4 CT connection . Updated 5.1.1 Self-consumption Mode . Added 5.1.4 Forced Charge/Discharge Function . Updated 7.2 App Setting Guide . Adjusted the details in Chapters 2 through 7 .

Preface

About This Manual

This manual describes the installation, electrical connection, commissioning and maintenance, APP operation of the inverter. Please first read the manual and related documents carefully before using the product and store it in a place where installation, operation and maintenance personnel can access it at any time. The illustration in this user manual is for reference only. This user manual is subject to change without prior notice. (Specific please in kind prevail.)

Target Group

Three phase ESS inverters must be installed by professional electrical engineers who have obtained relevant qualifications.





Scope

This manual is applicable to the following inverters:

- 5K
- 6K
- 8K
- 10K

Conventions

The following safety instructions and general information are used within this user manual.

 DANGER	Indicates an imminently hazardous situation which, if not correctly followed, will result in serious injury or death.
 WARNING	Indicates a potentially hazardous situation which, if not correctly followed, will result in serious injury or death.
 CAUTION	Indicates a potentially hazardous situation which, if not correctly followed, could result in moderate or minor injury.
 NOTICE	Indicates a potentially hazardous situation which, if not correctly followed, could result in equipment failure to run, or property damage.
 NOTE	Call attention to important information, best practices and tips: supplement additional safety instructions for your better use of the Three phase ESS inverter to reduce the waste of you resource.

CONTENTS

Preface

About This Manual

Target Group

Scope

Conventions

1. Safety

1.1 Symbols Used

1.2 Safety Precaution

2. Product Introduction

2.1 Overview

2.2 Product Appearance

2.3 Model Definition

3. Installation

3.1 Packing List

3.2 Selecting the Mounting Location

3.3 Mounting

4. Electrical Connection

4.1 Grounding

4.2 GRID/BACKUP Connection

4.3 Battery Connection

4.4 PV Connection

4.5 Meter/CT Connection

4.6 Communication Connection

5. System Operation

- 5.1 Inverter Working Mode
- 5.2 Startup/Shutdown Procedure

6. Commissioning

- 6.1 Inspection
- 6.2 Commissioning Procedure

7. User Interface

- 7.1 LED
- 7.2 App Setting Guide

8. Maintenance

- 8.1 Routine Maintenance
- 8.2 Inverter Troubleshooting
- 8.3 Removing the Inverter









9. Technical Specifications

1. Safety

Before using the inverter, please read all instructions and cautionary markings on the unit and manual. Put the instructions where you can take them easily.

The three phase ESS inverter of ours strictly conforms to related safety rules in design and test. Local safety regulations shall be followed during installation, operation and maintenance. Incorrect operation work may cause injury or death to the operator or a third party and damage to the inverter and other properties belonging to the operator or a third party.

1.1 Symbols Used

Safety Symbol	Description
	Danger of high voltage! Only qualified personnel may perform work on the inverter.
	Residual voltage exists after the inverter is powered off. It takes 5 minutes for system to discharge to a safe voltage.
	Danger of hot surface
 Do not disconnect under load!	Do not disconnect under load, otherwise there will be a danger of fire.
	Environmental Protection Use Period
	Refer to the operating instructions
	Don't dispose of the inverter with the household waste.
	Grounding terminal

1.2 Safety Precaution

- Installation, maintenance and connection of inverters must be performed by qualified personnel, in compliance with local electrical standards, wiring rules and requirements of local power authorities and/or companies.
- The temperature of some parts of the inverter may exceed 60°C during operation. Do not touch the inverter during operation to avoid being burnt.
- Ensure children are kept away from inverters.
- Don't open the front cover of the inverter. Apart from performing work at the wiring terminal (as instructed in this manual), touching or changing components without authorization may cause injury to people, damage to inverters and annulment of the warranty.
- Static electricity may damage electronic components. Appropriate methods must be adopted to prevent such damage to the inverter; otherwise the inverter may be damaged and the warranty annulled.
- Ensure the output voltage of the proposed PV array is lower than the maximum rated input voltage of the inverter; otherwise the inverter may be damaged and the warranty annulled.
- When exposed to sunlight, the PV array generates dangerous high DC voltage. Please operate according to our instructions, or it will result in danger to life.
- PV modules should have an IEC61730 class A rating.
- If the equipment is used in a manner not specified by the manufacturer, the protection provided by the equipment may be impaired.
- Completely isolate the inverter before maintaining. Completely isolate the inverter should: turn off the PV switch and disconnect the PV terminal, battery terminal, and AC terminal
- After the inverter is powered off, the remaining electricity and heat may still cause electric shock and body burns. Do not touch parts of inverter for 10 minutes after disconnection from the power sources.
- Prohibit inserting or pulling the AC and DC terminals when the inverter is running.
- In Australia, the inverter internal switching does not maintain the neutral continuity. And neutral integrity must be addressed by external connection arrangements.
- Don't connect ESS inverter in the following ways:
The BACKUP Port should not be connected to the grid;
A single PV panel string should not be connected to two or more inverters.

2. Product Introduction

2.1 Overview

ESS Inverter

The ESS inverters are high-quality inverter which can convert solar energy to AC energy and store energy into battery.

The inverter can be used to optimize self consumption, store in the battery for future use or feed into public grid. Work mode depends on PV energy and user's preference. It can provide power for emergency use during the grid lost by using the energy from battery and inverter (generated from PV).

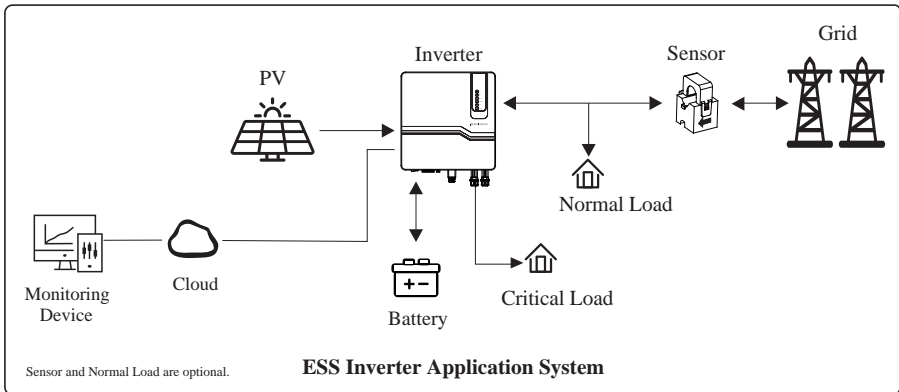

2.2 Product Appearance

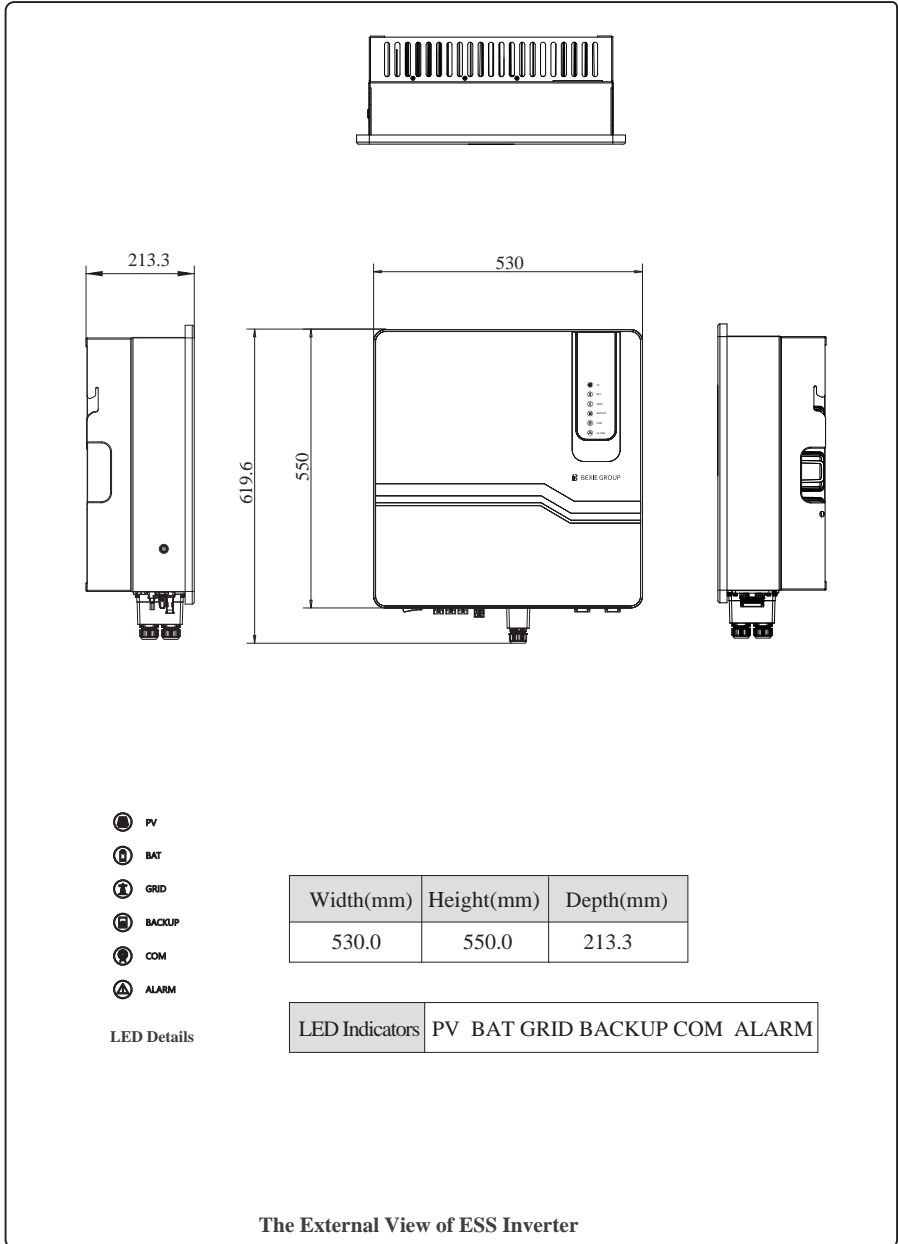

The External View of ESS Inverter

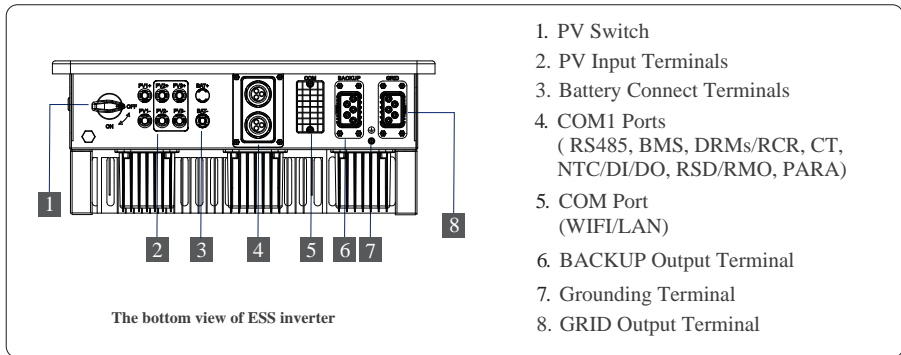

2.3 Model Definition

The letters in the product model have the specific informations.
(Take 5K as example.)

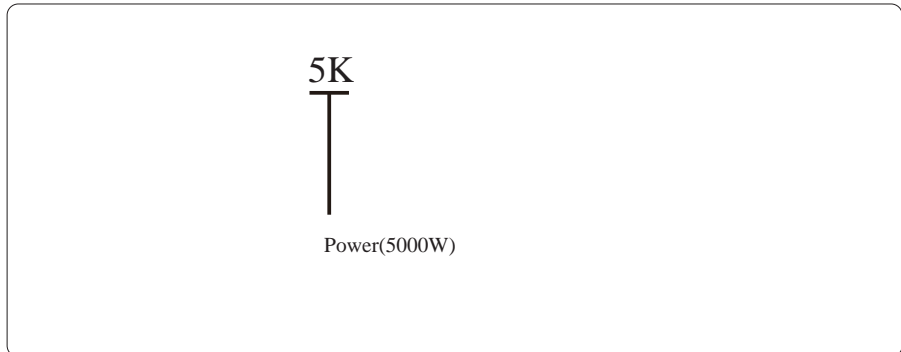

3. Installation

3.1 Packing List

After unpacking, please check the following packing list carefully for any damage or missing parts. If any damage or missing parts occurs, contact the supplier for help.

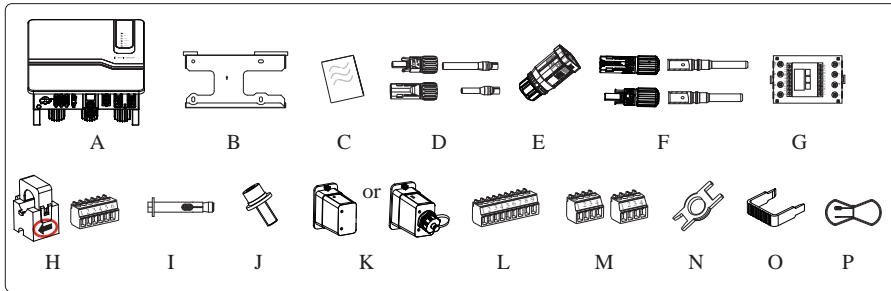

Number	Quantity	Description
A	1	Inverter
B	1	Mounting bracket
C	1	File package
D	2/2 for 5/6K; 3/3 for 8/10K	PV terminal connector group (PV+/PV-)
E	2	GRID/BACKUP connector
F	1/1	Battery terminal connector group (BAT+/BAT-)
G	1	Meter (Optional)
H	1	CT pack (3pcs CT + 1pcs 6-Pin terminal)
I	4	M10 Expansion screws
J	1	M6 Security screw
K	1	WIFI/LAN module (Optional)
L	1	9-Pin terminal
M	2	4-Pin terminal
N	1	Removal tool for PV/BAT connector
O	1	Removal tool for GRID/BACKUP connector
P	1	Battery Temperature sensor (Optional)

3.2 Selecting the Mounting Location

3.2.1 Installation Environment Requirements

- The storage inverter protection class is IP65 and can be mounted indoors or outdoors.
- To ensure optimum operation and long service life, the ambient temperature must be below 50°C.
- Do not install the inverter in a rest area since it will cause noise during operation.
- The inverter carrier must be fire-proof. Do not mount the inverter on flammable building materials.
- Ensure that the wall meets the requirements of the inverter installation.
- Product label and warning symbols shall be clear to read after installation.
- The installation height should be reasonable and make sure it is easy to operate and view the display.
- Please avoid direct sunlight, rain exposure, snow cover.

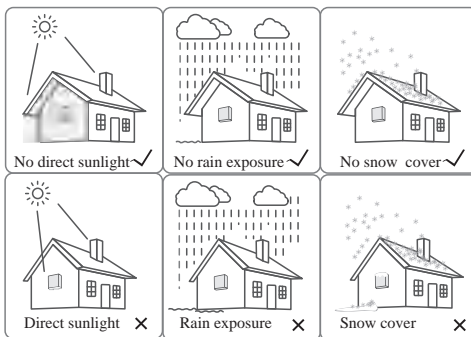

3.2.2 Mounting Requirements

Mount the inverter vertically or tilted backward by max 15°. The device can not be installed with a wrong mode and the connection area must point downward.

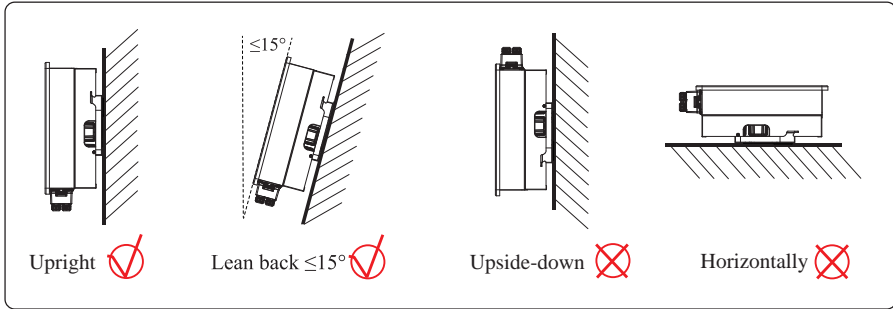

3.2.3 Installation Space Requirements

To ensure the inverter normally and easy to operate, there are requirements on available spaces of the inverter, e.g. to keep enough clearance. Refer to the following figures.

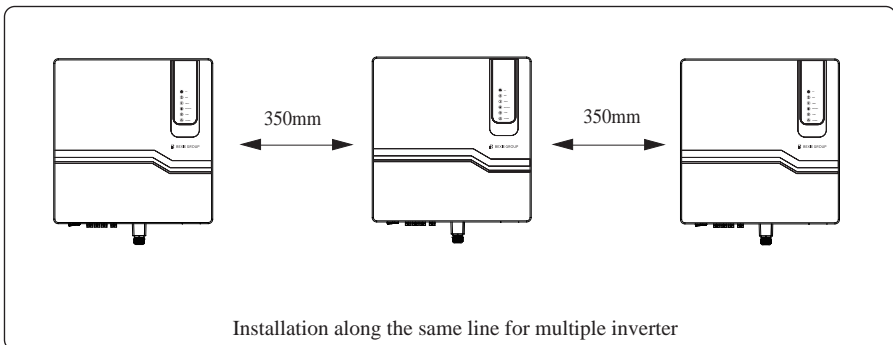
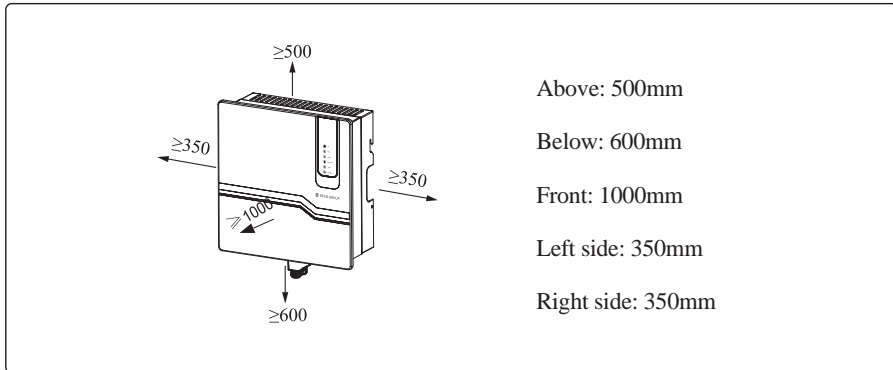

3.3 Mounting

Before mounting the inverter, you have to prepare expansion screws and security screw.

Step 1. Install the mounting bracket

1. Use a level ruler to mark the position of the 4 holes on the wall. Refer to Figure a. And drill 4 holes, 12mm in diameter and 60mm in depth. Refer to Figure b.
2. Knock the expansion screw kit into the hole with a hammer. Refer to Figure c.

Note:

Do not remove the nut unit in this step.

Before tapping the expansion screw kit into the hole, you need to screw the bolt out 1-2 turns.

3. After fastening 4 bolts, the expansion bolts are tight and not loose, and then unscrew the threaded bolts, gaskets. Refer to Figure c.
4. Install and fix the mounting bracket on the wall. Refer to Figure d.

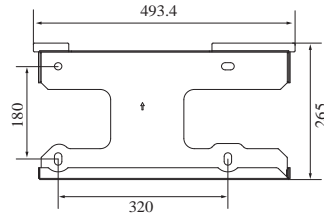

Unit: mm

Step 2. Install the inverter on the mounting bracket. Then lock the inverter using the security screw. Refer to Figure e, Figure f.

<p>a Set bracket horizontally. Mark the holes position on the wall.</p>	<p>b Drill the holes. Ø: 12mm; Depth: 60mm</p>	<p>c Expansion screw group (M10; 4 suites)</p>
<p>d Install the bracket. M10 3.0 N·m</p>	<p>e</p>	<p>f M6 Security screw; 2.5N·m</p>

<p>DANGER</p>	<p>Before drilling holes, check whether there are electric power pipes or other pipes buried in the walls to avoid risks.</p>
<p>CAUTION</p>	<p>To prevent potential damages and injuries from inverter falling down, please hang the inverter on the bracket, do not loosen grip unless confirm the inverter is well mounted.</p>

4. Electrical Connection

This chapter shows the details connection of Three phase ESS inverter. The following illustration only uses the ESS inverters as an example.

 DANGER	Ensure that inverter and all cables to be installed are completely powered off during whole installation and connection. Otherwise, high voltage may result in fatal injury.
---	--





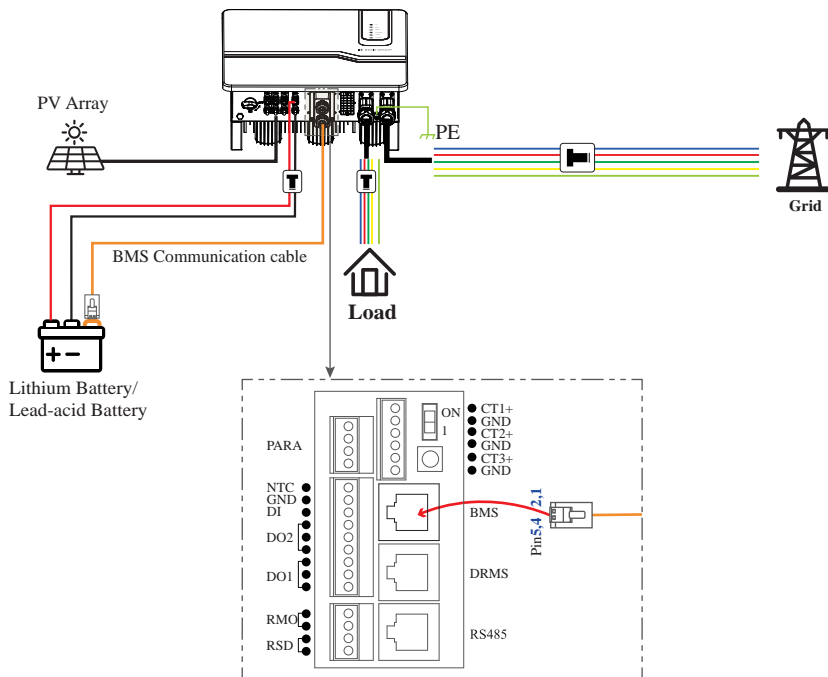



Three phase ESS inverter system connection diagram:

Connection mode for whole-house load



Note:

1. BMS communication connection is only for lithium battery.
2. About breakers:
 DC breaker on battery side $\geq 80A$
 AC breaker on load side $\geq 40A$
 AC breaker on grid side $\geq 40A$
 The specifications of main breaker and normal load breaker depend on household loads.

COM	
L1	
L2	
L3/Positive	
Negative	
N	
PE	
Breaker	

Non-parallel connection mode

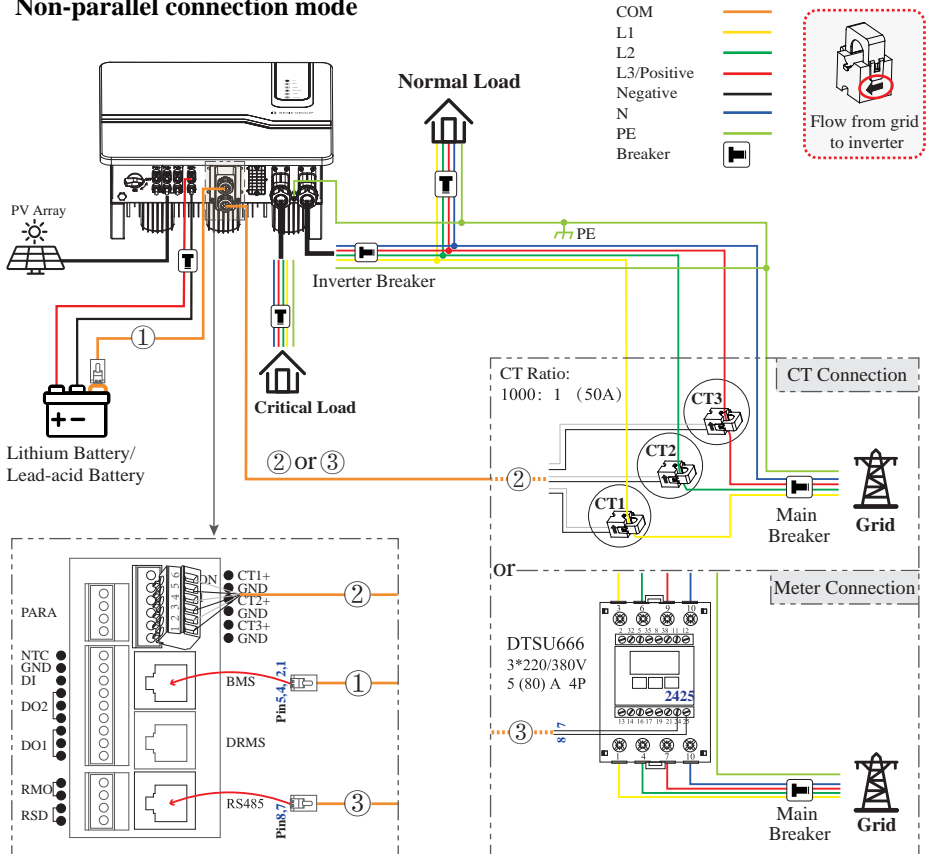

- ① BMS communication connection
- ② CT communication connection
- ③ Meter communication connection

Note:

1. BMS communication connection is only for lithium battery.
2. Meter is optional.
3. About breakers: DC breaker on battery side $\geq 80A$; AC breaker on critical load side $\geq 40A$; AC breaker on inverter side $\geq 40A$. The specifications of main breaker and normal load breaker depend on household loads.

<p>DANGER</p>	<p>Ensure that the inverter and all cables to be installed have been completely powered off during the whole process of installation and connection. Otherwise, high voltage may result in fatal injury.</p>
----------------------	--

Parallel connection mode-Scheme A (N=2)

- COM —
- L1 —
- L2 —
- L3/Positive —
- Negative —
- N —
- PE —
- Breaker

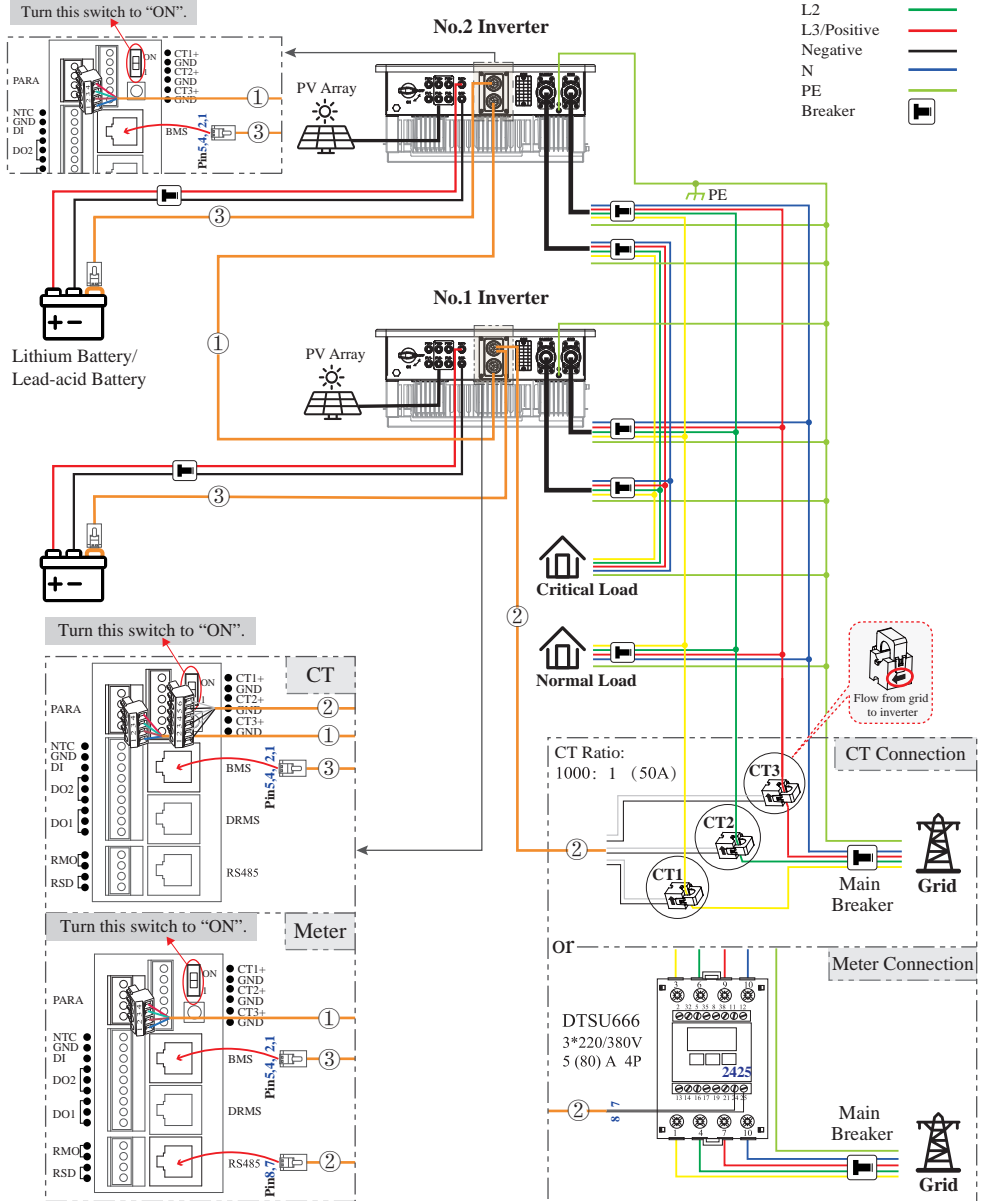

- ① Parallel communication connection
- ② CT/Meter communication connection
- ③ BMS communication connection

*These communication cables can be connected to any inverter, but they must be inserted into the same inverter and we call this inverter No. 1 inverter.

Note for Scheme A:

1. BMS communication connection is only for lithium battery.
2. With parallel connection mode, it is necessary to connect APP to one of inverters and then go to [Console > Hybrid Setting> Other >Parallel mode](#) page to enable [Parallel mode](#) on APP. Please refer to section 7.2.3.

3. About breakers:

DC breaker on battery side $\geq 80A$

AC breaker on critical load side $\geq 40A$

AC breaker on inverter side $\geq 40A$

The specifications of main breaker and normal load breaker depend on household loads.



DANGER

Ensure that the inverter and all cables to be installed have been completely powered off during the whole process of installation and connection. Otherwise, high voltage may result in fatal injury.

Parallel connection mode-Scheme B ($2 < N \leq 9$)

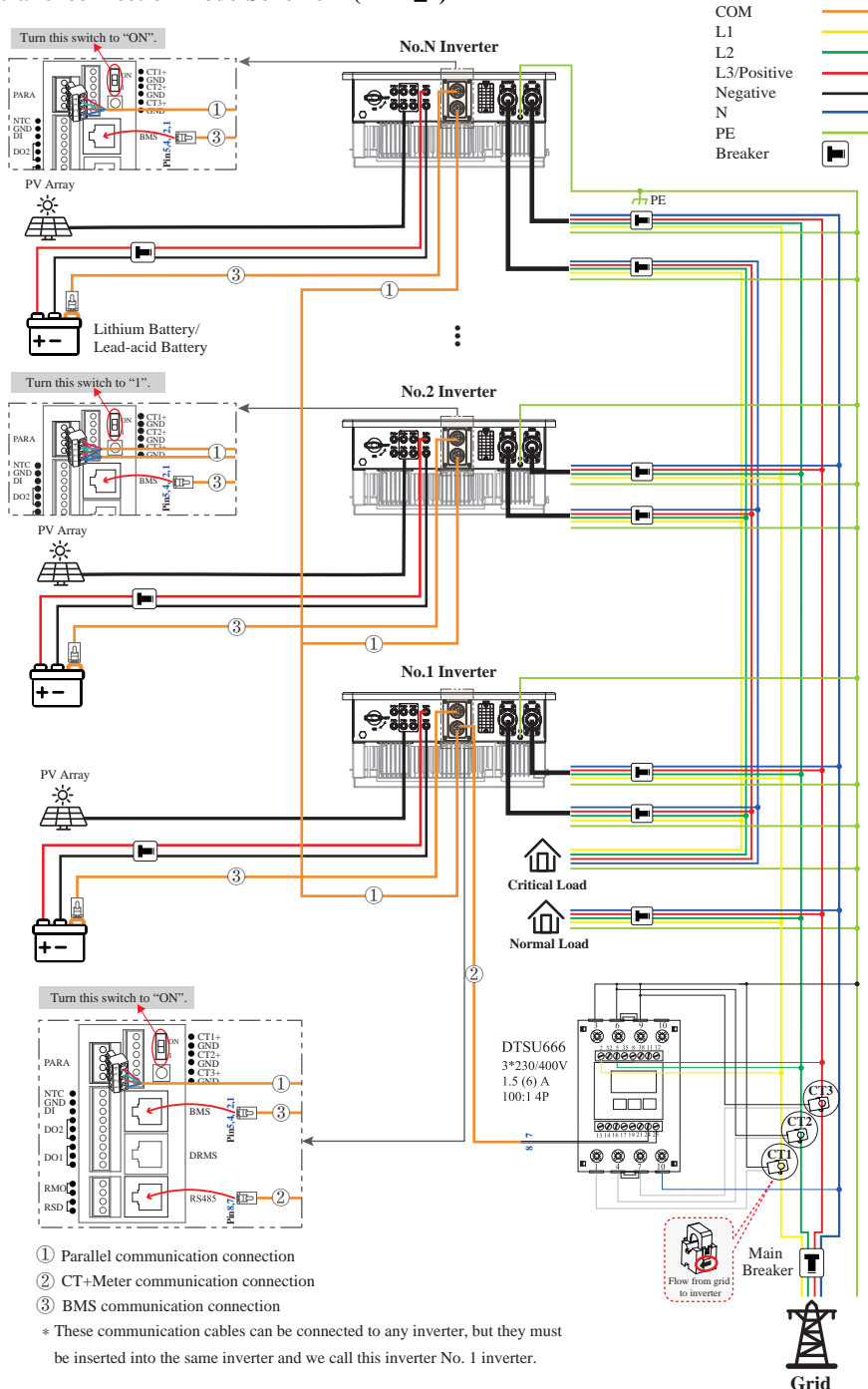

Note for Scheme B:

1. BMS communication connection is only for lithium battery.
2. It is necessary to turn the matched resistance switch of No. 1 inverter and No. N inverter to “ON” and turn others to “1” in parallel connection mode.
3. With parallel connection mode, it is necessary to connect APP to one of inverters and then go to [Console > Hybrid Setting> Other >Parallel mode](#) page to enable [Parallel mode](#) on APP. Please refer to section 7.2.3.
4. About breakers:
 DC breaker on battery side $\geq 80A$
 AC breaker on critical load side $\geq 40A$
 AC breaker on inverter side $\geq 40A$
 The specifications of main breaker and normal load breaker depend on household loads.

 DANGER	<p>Ensure that the inverter and all cables to be installed have been completely powered off during the whole process of installation and connection. Otherwise, high voltage may result in fatal injury.</p>
---	--

4.1 Grounding

A protective earth (PE) terminal is equipped at the side of the inverter. Please be sure to connect this PE terminal to the PE bar for reliable grounding. AWG 10 yellow green lines are recommended.

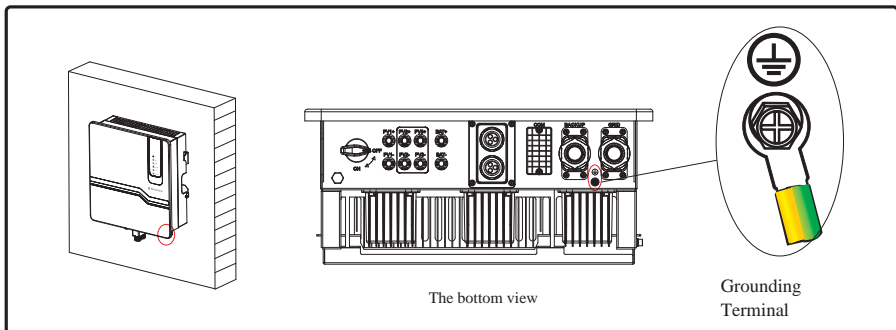

 WARNING	<p>The inverter must be grounded; otherwise, there may be electric shock risk.</p>
--	--

 CAUTION	<p>If the positive pole or negative pole of the PV array is required to be grounded, then the inverter output (to AC grid) must be isolated by transformer in accordance with IEC62109-1, -2 standards.</p>
--	---

4.2 GRID/BACKUP Connection

If necessary, please refer to below to disassemble the GRID/BACKUP terminal.

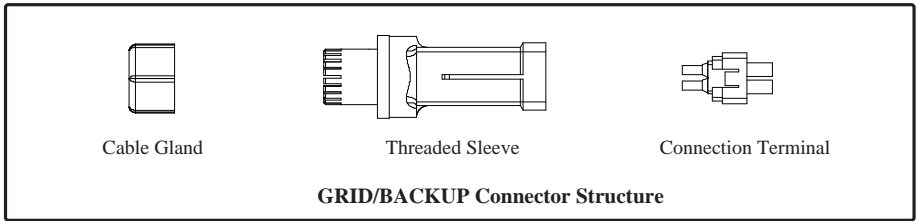
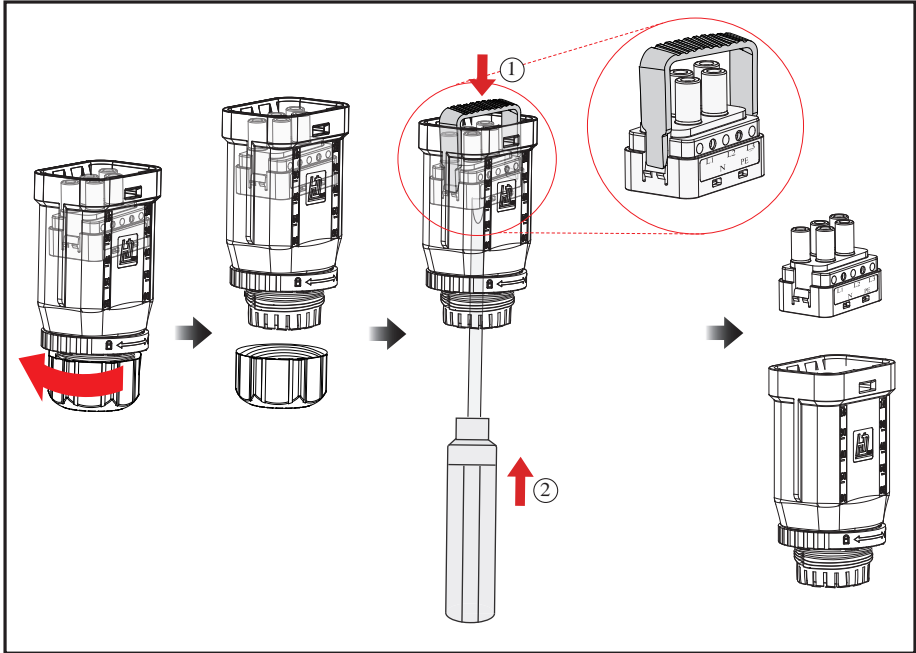

Before connecting the GRID/BACKUP terminal, ensure that both the AC terminal and the DC terminal are powered off and the PV switch is OFF. Otherwise there is a risk of high voltage shock.

GRID/BACKUP connection please refer to below.

Step 1: Assemble the AC connector.

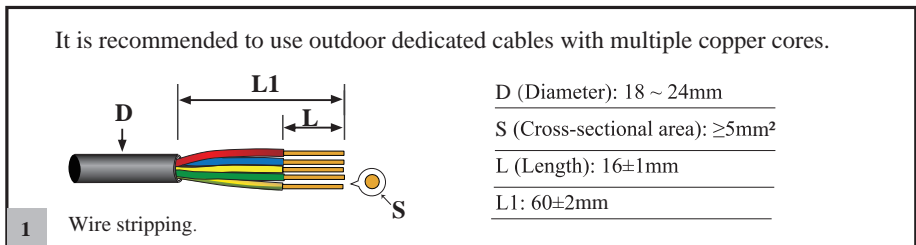

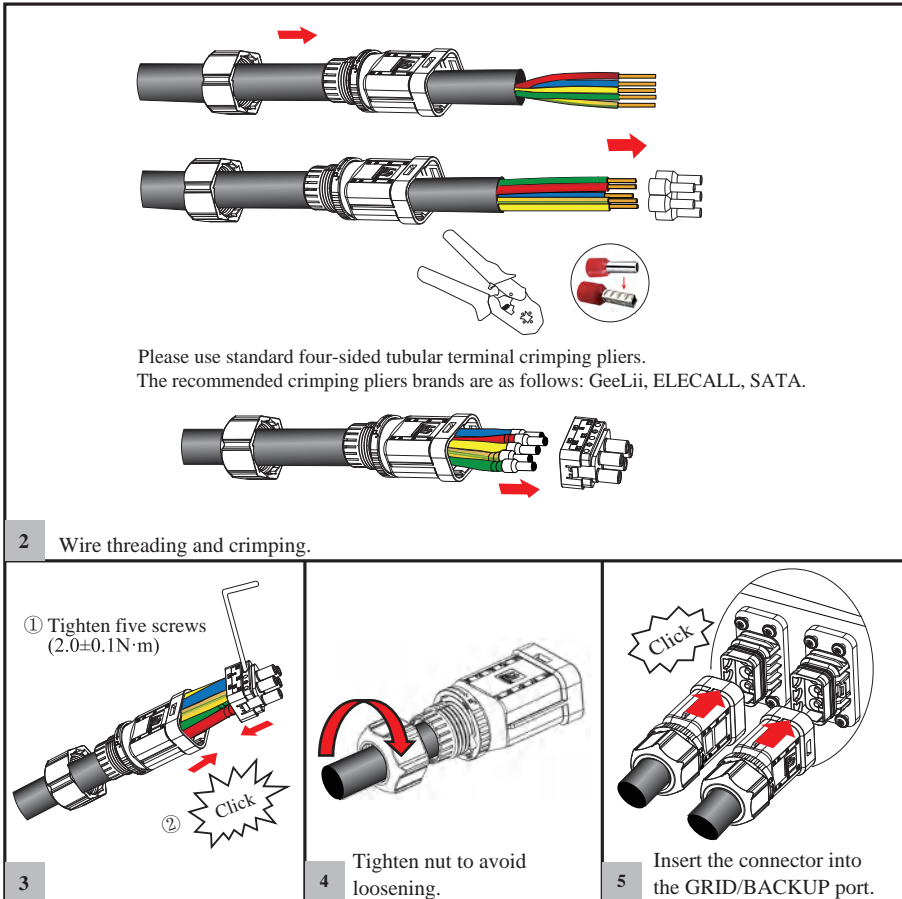

Step 2: Connect the AC connector.

An AC breaker ($\geq 40\text{A}$) should be installed between inverter and the GRID/BACKUP.

- Before connecting the AC cable from inverter to AC breaker, you should confirm the AC breaker is working normally. Turn off the AC breaker and keep the status.
- Connect the PE conductor to grounding electrode, and connect the N and L conductors to AC breaker.
- Connect the AC breakers to the GRID/BACKUP.



NOTICE

- Multiple inverters are not allowed to share a circuit breaker.
- Load is not allowed to connect between the grid and the AC breaker.

4.3 Battery Connection

Three phase ESS inverter now only supports the lithium / lead-acid battery. The recommended lithium battery brands are as follows: Weco, Pylon tech, UZ energy series.

This part in this manual only describe the battery connection on inverter side. If you need more detailed connection information about the battery side, please refer to the manual of the battery you are using.

Before connecting to battery, please install a separate DC breaker between inverter and battery.

This ensures the inverter can be securely disconnected during maintenance.

Using crimping tool to stitch. Red-circled area can't be crimped. **Click**

Positive Connector

Negative Connector

Diameter 5.5~7.5mm

8mm

8mm

+

-

Pay attention to the difference between the battery terminal and the PV terminal to avoid confusion.

a Cross-sectional area of the battery cable: 8~10mm² (recommended).
Length of the battery cable should be less than or equal to 3m.

DC Breaker 80A

Positive Connector

Negative Connector

Click

BAT+

BAT-

b This product is not equipped with DC breakers.

c Warning!
Reverse polarity will damage the inverter!

 <p>WARNING</p>	<ul style="list-style-type: none"> • Reverse polarity will damage the inverter! • Be careful of electric shock and chemical hazards! • To reduce risk of injury, please use the suitable recommended cable size.
---	---

Battery Communication Connection

If the battery type is lithium battery which need communication between the inverter and battery management system (BMS), the connection must be installed. Please refer to section 4.6.1 for details.

NTC connection for lead-acid battery

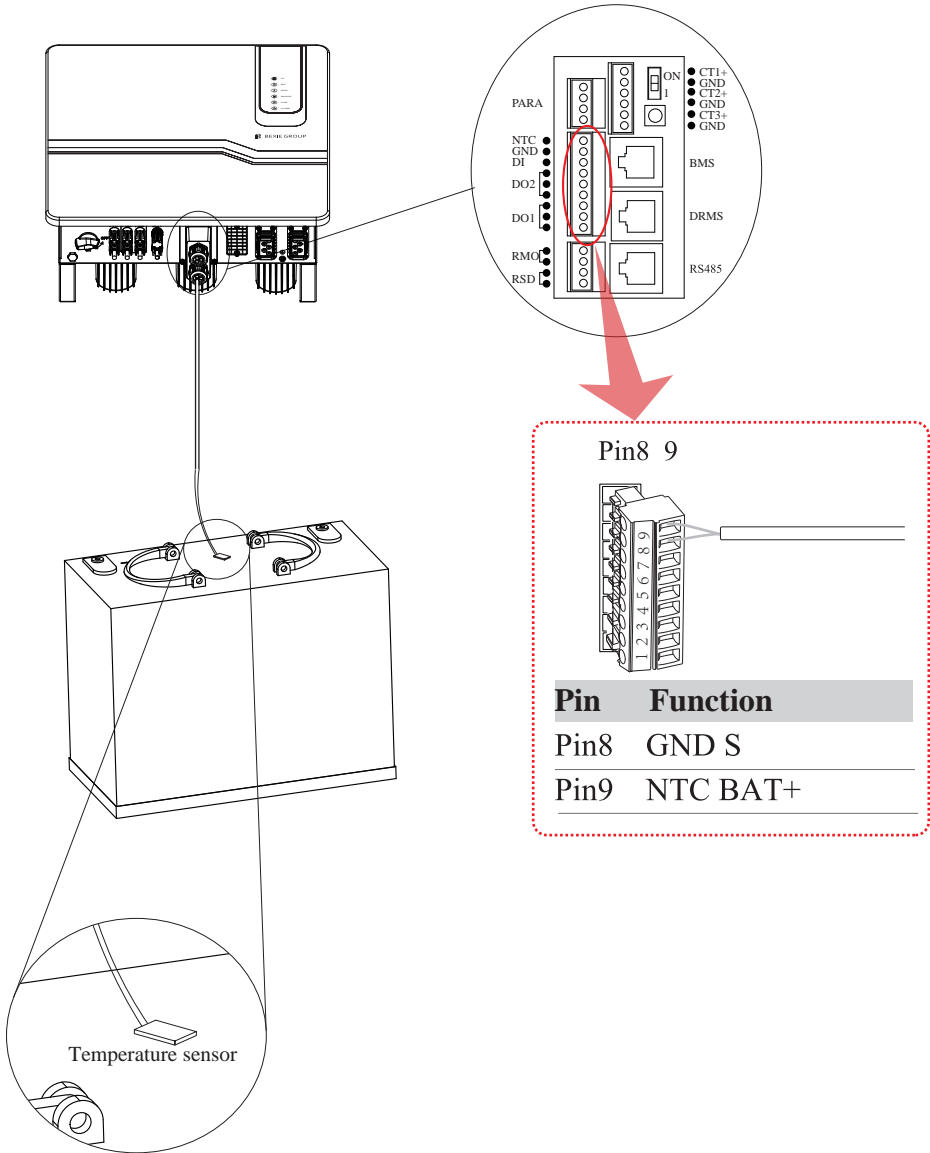

4.4 PV Connection

PV connection please refer to below.

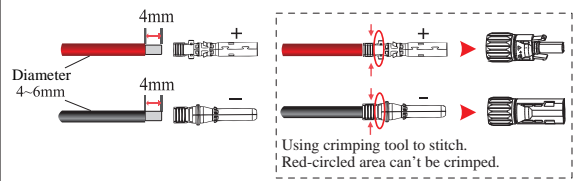
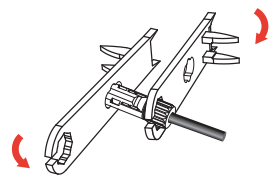
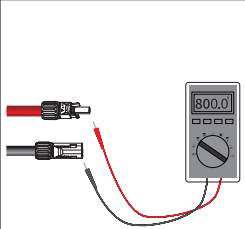
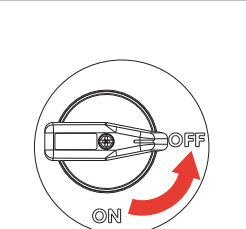
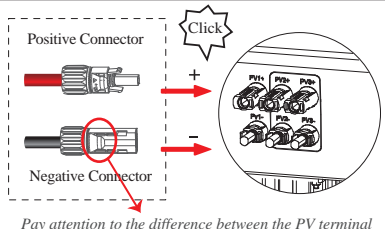
 <p>Note: DC cable should be dedicated PV cable (suggesting using 4-6mm² PV1-F cable).</p>		 <p>Tighten the waterproof nuts on each connector with a tool to avoid loosening.</p>
<p>1 Wires making and crimping.</p>	<p>2</p>	
 <p>Test string voltage and confirm string polarity.</p>	 <p>Ensure that the PV switch is OFF.</p>	 <p>Insert the positive and negative connectors into the PV+/PV- ports until a "click" sound is heard.</p>
<p>3</p>	<p>4</p>	<p>5</p>

 <p>NOTICE</p>	<ul style="list-style-type: none"> • Before connecting the PV panels, make sure the plug connector have the correct polarity. Incorrect polarity could permanently damage the inverter. • PV array shouldn't be connected to the grounding conductor. • The minimum insulation resistance to ground of the PV panels must exceed 33.3kΩ, there is a risk of shock hazard if the requirement of minimum resistance is not met.
---	--

 <p>WARNING</p>	<p>Please check polarity of PV connectors!</p> <p>If polarity reversed, do not try to disconnect any PV connector until the irradiance declines and the DC currents fall below 0.5 A! Only then disconnect the PV plugs and correct the polarity before reconnecting.</p>
---	---

4.5 Meter/CT Connection (Direct connect)

You can monitor usage with a meter or a CT.

4.5.1 Meter Connection

This section is applicable to non-parallel connection mode only.

Three phase ESS inverter supports the meter CHINT-DTSU666 meter by default.

The meter is optional.

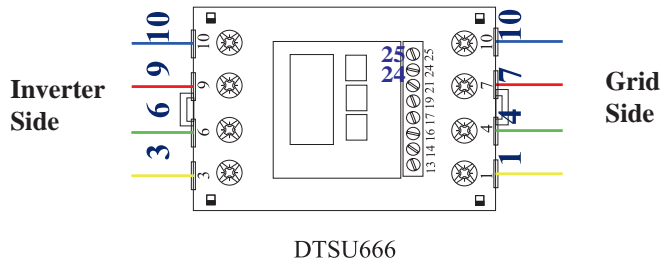

Before connecting to Grid, please install a separate AC breaker ($\geq 40A$; not equipped) between meter and Grid. This ensures the inverter can be securely disconnected during maintenance.

The connection diagram of power cable of meter is as shown in the figure below:

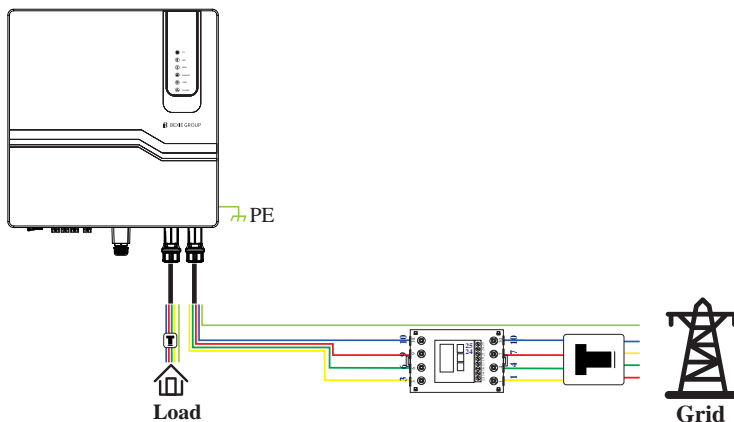

Please refer to the meter instruction manual for details.

4.5.2 CT Connection

Before connecting to Grid, please install a separate AC breaker ($\geq 40A$; not equipped) between CT and Grid. This ensures the inverter can be securely disconnected during maintenance.

The connection diagram of power cable of CT is as shown in the figure below:

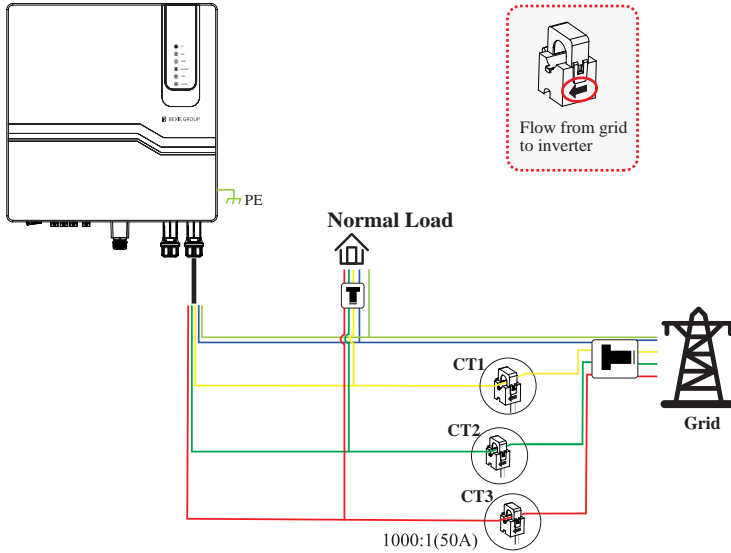

Please pay attention to the Current transformer (CT) connection. The arrow on the CT indicates the current flow from grid to inverter. And lead the live line through the detection hole of CT.

 NOTE	<p>The current direction from grid to inverter is defined as positive and current direction from inverter to grid is defined as negative.</p>
---	---

4.6 Communication Connection

There are communication interfaces in the communication port on the bottom of the inverter as show below :

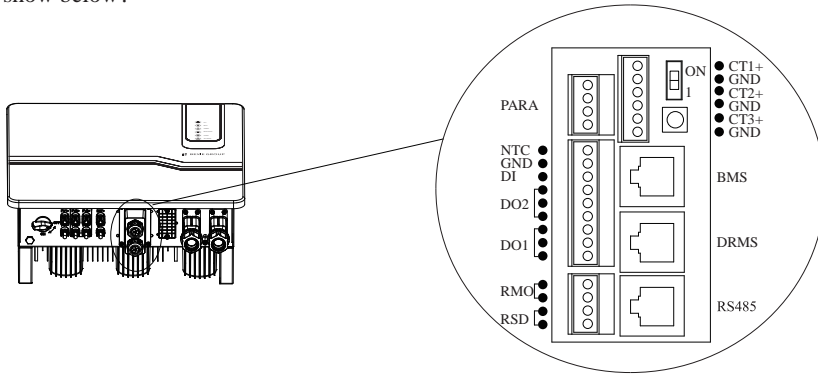

Interface		Descriptions
PARA		4-Pin interface for parallel communication
		A matched resistance switch for parallel communication
RS485		RS485 communication (Monitoring/Meter)
DRMs		Demand response mode for Australia application
CT		6-Pin interface for grid/load current sensor.
BMS		Lithium battery communication interface
9-Pin	NTC	Temperature sensor terminal of lead-acid battery
	DRY	DI/DO control
RSD/RMO		RSD control power and remote off
COM		For WIFI/LAN communication.

4.6.1 BMS Connection (Only for Lithium Battery)

RJ45 Terminal Configuration of Battery Communication at Inverter Side



NOTE

This manual ONLY illustrates the pinout sequence of BMS at INVERTER SIDE. For details about the pinout sequence at battery side, see the user manual of the battery you use, and the following pinout diagram of battery side is only for illustration.

Standard RJ45 Pinout

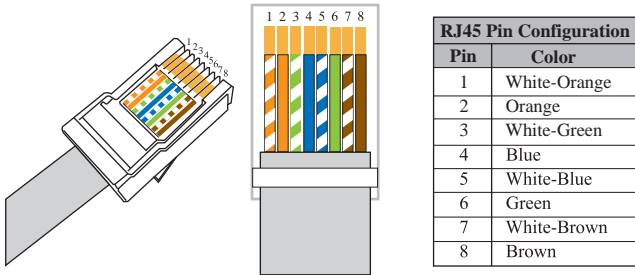

Always face the flat side of the terminal, and count the pin slots from left to right correspond to 1 to 8. Read the pin definitions of both the battery and inverter carefully.

Pin definition of terminal

INVERTER:

Inverter	
Pin	Definition
1	RS485_A
2	RS485_B
3	GND
4	CAN_H
5	CAN_L
6	/
7	/
8	/

BATTERY:

An example of the battery's pin configuration is as following.

Battery (example)	
Pin	Definition
1	NC
2	NC
3	GND_S
4	CAN_H
5	CAN_L
6	GND_S
7	NC
8	NC

CAN BUS connection principle:

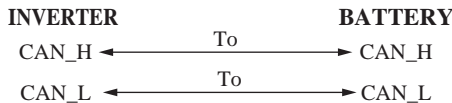

BMS communication cable prepare.

- ① Prepare RJ45 terminals and strip appropriate length of COM cables.
- ② According to pin definitions and cable order, assemble the RJ45 terminals and crimp communication wires. There are two methods to assemble the RJ45 terminals.
- ③ Then label the RJ45 terminals (BAT or INV) to avoid confusion.
- ④ After finishing wire-making, use a multimeter or other specific tool to determine if your cable is good, bad, or wired incorrectly.

Method 1: Use the INVERTER RJ45 pinout as the standard pinout to crimp wires, then the battery side will be a non-standard one (special pinout). Cut off the other no-used wires (1/2/3/6/7/8) for the battery RJ45 terminal.



Method 2: Use the BATTERY RJ45 pinout as the standard pinout to crimp wires, then the inverter side will be a non-standard one (special pinout). Cut off the other no-used wires (1/2/3/6/7/8) for the inverter RJ45 terminal.



BMS communication cable connection.

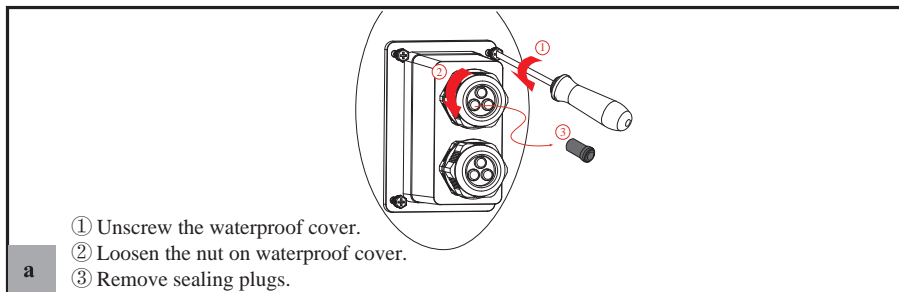

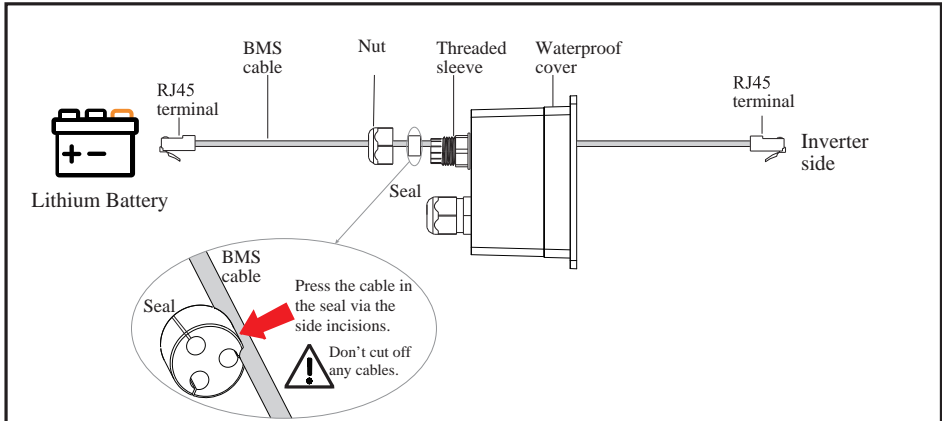

b Lead the BMS cable through the nut, seal and waterproof cover in turn.

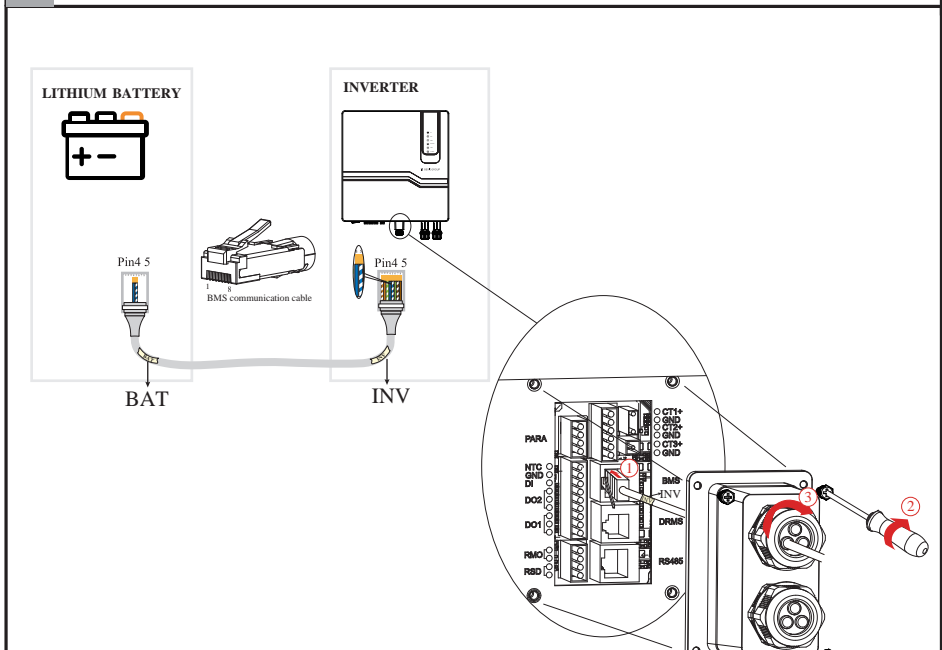

- ① Insert the RJ45 terminal into the corresponding port.
- ② Screw the waterproof cover back to inverter firmly with 4 x M4 screws(1.2N·m).
- ③ Install the seal into the threaded sleeve, fasten the nut.

c

4.6.2 DRMs Connection

DRMs is a shortened form for “inverter demand response modes”. It is a compulsory requirement for inverters in Australia.

Note: With DRMs connection, it is necessary to connect APP to inverter and then go to [Console > Other Setting](#) page to enable [DRM function](#) on APP. Please refer to section 7.2.3.

RJ45 Terminal Configuration of DRMs

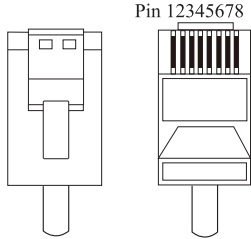

DRMs

PIN	1	2	3	4	5	6	7	8
Function Description	DRMs1/5	DRMs2/6	DRMs3/7	DRMs4/8	REF	GND	/	/

Refer to the following steps:

a

- ① Unscrew the waterproof cover.
- ② Loosen the nut on waterproof cover.
- ③ Remove sealing plugs.

c

- ① Insert the RJ45 terminal into the corresponding port.
- ② Screw the waterproof cover back to inverter firmly with 4 x M4 screws (1.2N·m).
- ③ Install the seal into the threaded sleeve, fasten the nut.

b Make the RJ45 terminal according to above function description of each Pin definition.
Lead the DRMs/RCR cable through the nut, seal and waterproof cover in turn.

⚠ Don't cut off any communication cables.

Press the DRMs cable in the seal via the side incisions.

4.6.3 RS485 Communication (Monitoring/Meter Connection)

RJ45 Terminal Configuration of Monitoring/Meter Communication

Pin 12345678

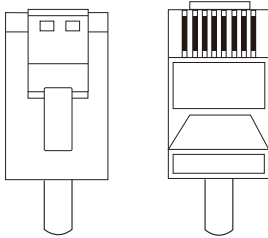

PIN	1	2	3	4	5	6	7	8
Function Description	RS485_A	RS485_B	/	/	/	/	RS485_A	RS485_B

Inverter	Meter
Pin7(RS485_A)	Pin24
Pin8(RS485_B)	Pin25

Inverter	Monitoring
Pin1(RS485_A)	RS485_A
Pin2(RS485_B)	RS485_B

Meter cable connection overview

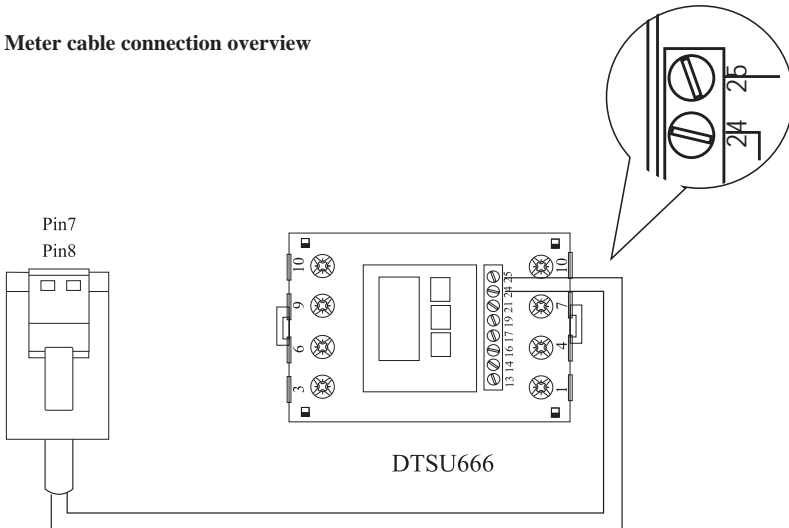

Connect meter. Refer to the following steps:

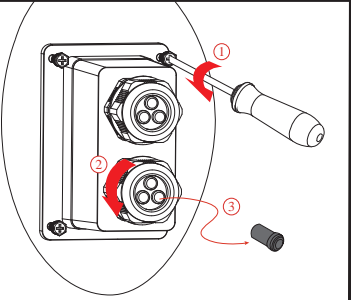

a

- ① Unscrew the waterproof cover.
- ② Loosen the nut on waterproof cover.
- ③ Remove sealing plugs.

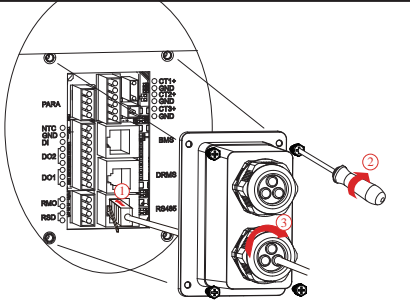

c

- ① Insert the RJ45 terminal into the corresponding port.
- ② Screw the waterproof cover back to inverter firmly with 4 x M4 screws (1.2N·m).
- ③ Install the seal into the threaded sleeve, fasten the nut.

b Make the RJ45 terminal according to above function description of each Pin definition.
Lead the meter communication cable through the nut, seal and waterproof cover in turn.

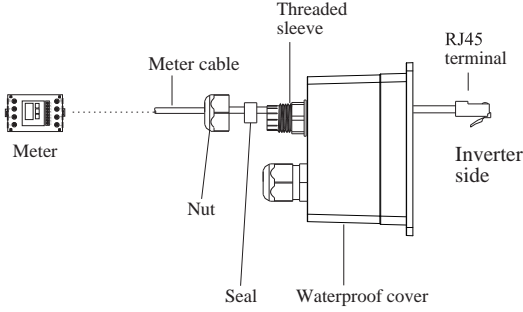

Meter

Meter cable

Nut

Threaded sleeve

Waterproof cover

Seal

RJ45 terminal

Inverter side



Don't cut off any communication cables.

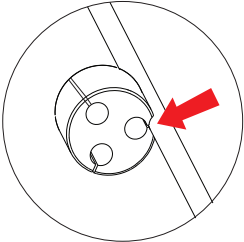

Press the meter cable in the seal via the side incisions.

4.6.4 CT Connection

CT cable connection overview

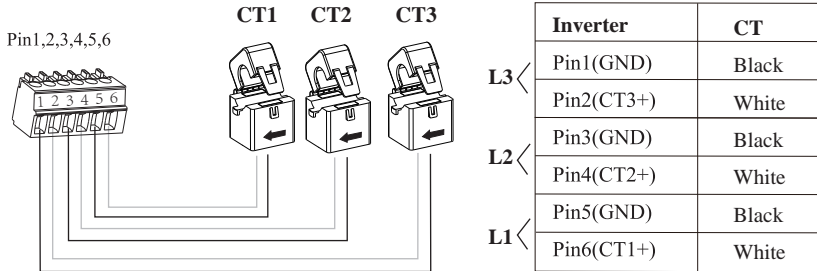

Connect CT. Refer to the following steps:

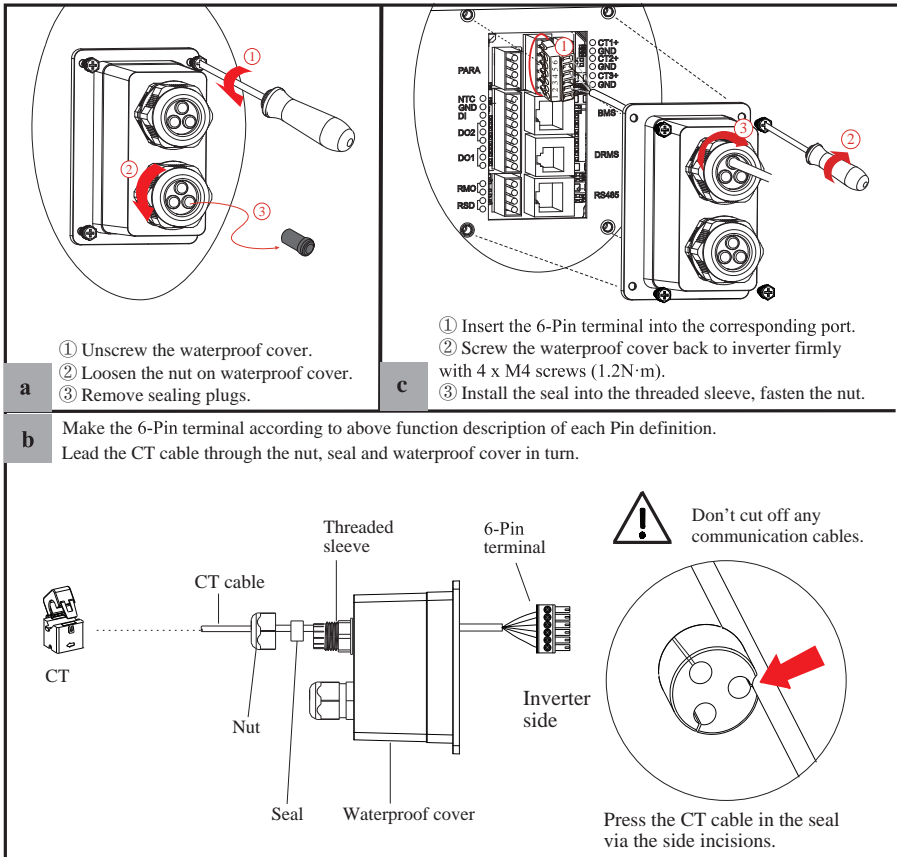

4.6.5 Parallel Communication Connection

4-Pin Terminal Configuration of parallel Communication



PIN	1	2	3	4
Function Description	GND_S	PARA_SYNC	CAN_L	CAN_H

Parallel communication cable connection overview

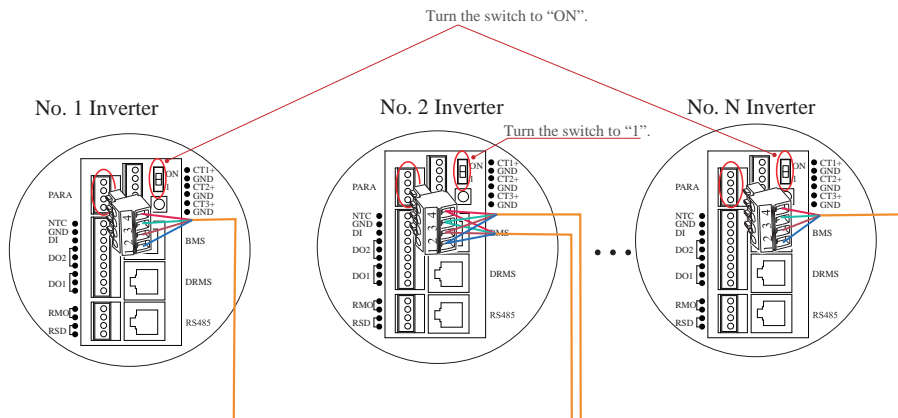

It is necessary to turn the matched resistance switch of No. 1 inverter and No. N inverter to "ON" and turn the matched resistance switch of others to "1" in parallel connection mode.

No. 1 Inverter	No. 2 Inverter	No. N Inverter
Pin4(CAN_H)	Pin4(CAN_H)		Pin4(CAN_H)
Pin3(CAN_L)	Pin3(CAN_L)		Pin3(CAN_L)
Pin2(PARA_SYNC)	Pin2(PARA_SYNC)		Pin2(PARA_SYNC)
Pin1(GND_S)	Pin1(GND_S)		Pin1(GND_S)

Refer to the following steps:

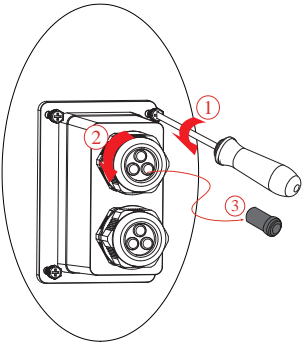

- ① Unscrew the waterproof cover.
- ② Loosen the nut on waterproof cover.
- ③ Remove sealing plugs.

a

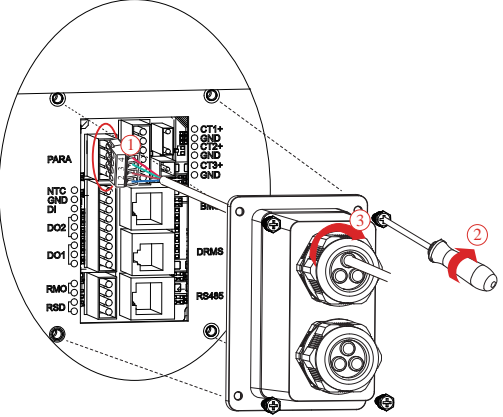

- ① Insert the 4-Pin terminal into the corresponding port.
- ② Screw the waterproof cover back to inverter firmly with 4 x M4 screws(1.2N·m).
- ③ Install the seal into the threaded sleeve, fasten the nut.

c

b Make the 4-Pin terminal according to above function description of each Pin definition.
Lead the Parallel cable through the nut, seal and waterproof cover in turn.

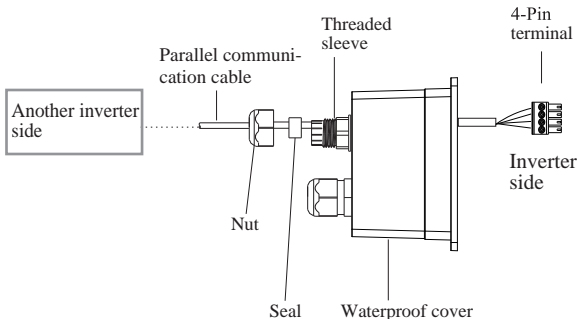



Don't cut off any communication cables.

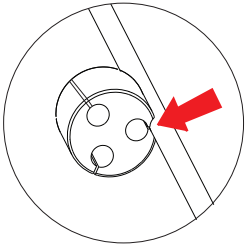

Press the Parallel communication cable in the seal via the side incisions.

4.6.6 NTC/DI/DO Connection(s)

9-Pin Terminal Configuration of Auxiliary Communication

Pin 123456789

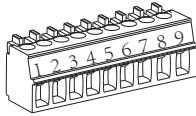

PIN	Function Description
1	NO (Normal Open)
2	COM
3	NC (Normal Close)
4	NO (Normal Open)
5	COM
6	NC (Normal Close)
7	DI
8	GND S
9	NTC BAT+

Refer to the following steps:

a

- ① Unscrew the waterproof cover.
- ② Loosen the nut on waterproof cover.
- ③ Remove sealing plugs.

b

Make the 9-Pin terminal according to above function description of each Pin definition for the auxiliary port you want to use.

Lead the NTC/DI/DO cable(s) through the nut, seal and waterproof cover in turn.

Don't cut off any communication cables.

Press the NTC/DI/DO cable(s) in the seal via the side incisions.

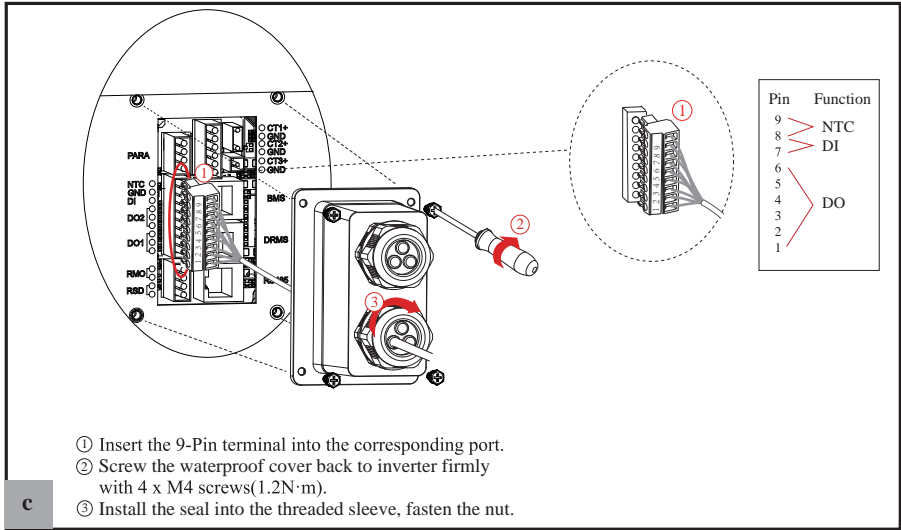

4.6.7 RSD/RMO Connection(s)

4-Pin Terminal Configuration of RSD/RMO Communication

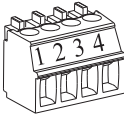

PIN	1	2	3	4
Function Description	+12V	GND	GND	REMOTE OFF

Refer to the following steps:

① Unscrew the waterproof cover.
② Loosen the nut on waterproof cover.
③ Remove sealing plugs.

a

① Insert the 4-Pin terminal into the corresponding port.
② Screw the waterproof cover back to inverter firmly with 4 x M4 screws(1.2N·m).
③ Install the seal into the threaded sleeve, fasten the nut.

c

b Make the 4-Pin terminal according to above function description of each Pin definition.
Lead the RSD/RMO cable through the nut, seal and waterproof cover in turn.

Another inverter side

RSD/RMO communication cable

Nut

Seal

Threaded sleeve

Waterproof cover

4-Pin terminal

Inverter side

Don't cut off any communication cables.

Press the RSD/RMO communication cable in the seal via the side incisions.

4.6.8 WiFi/LAN Module Connection (Optional)

For details, please refer to the corresponding Module Installation Guide in the packing.

The appearance of modules may be slightly different. The figure shown here is only for illustration.

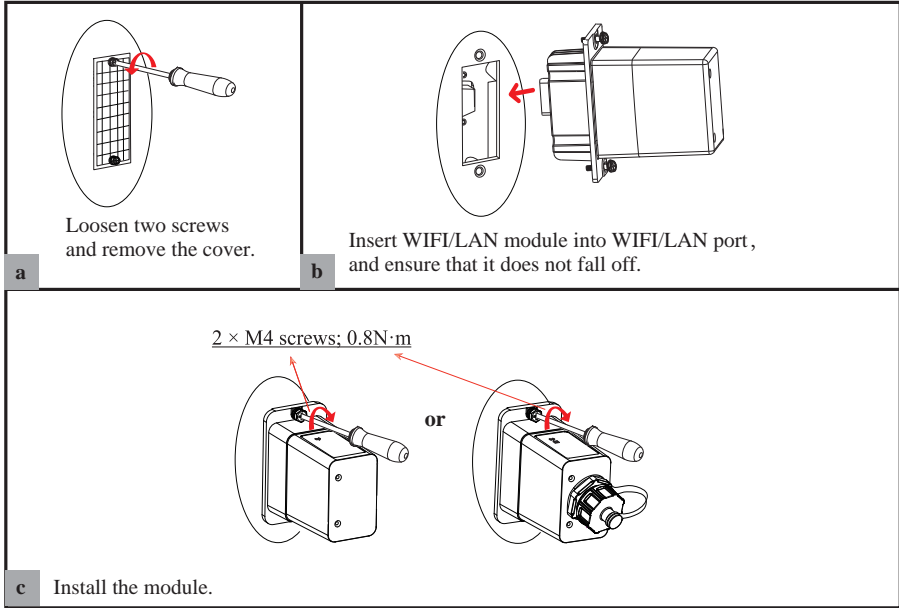

5. System Operation

5.1 Inverter Working Mode

The inverter supports several different working modes.

5.1.1 Self-consumption Mode

Go to [Console > Hybrid Setting > Work mode](#) page, and select [Self-consumption mode](#).

Under Self-consumption mode, the priority of PV energy consumption will be Load > Battery > Grid, that means the energy produced by PV gives priority to powering local loads, the excess energy is used to charge the battery and the remaining energy is fed into the grid.

This is the default mode to increase self-consumption rate. There are several situations of Self-consumption working mode based on PV energy.

a) Wealthy PV Energy

When PV energy is wealthy, the PV energy will be first consumed by loads, the excess energy will be used to charge the battery and then the remaining energy will be fed into the grid.

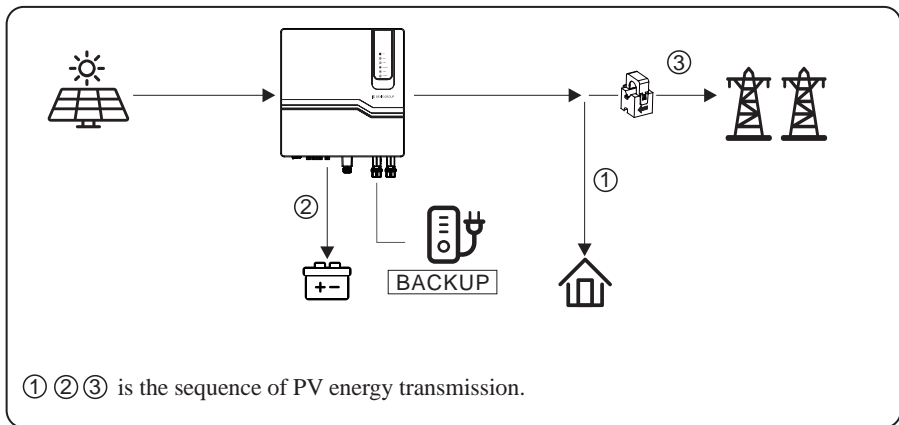

b) Limited PV power

When the PV energy is not enough to cover all consumption, the PV energy will be entirely used by loads, and the insufficient part will be supplied by battery. Then still insufficient parts will be supplied by grid.

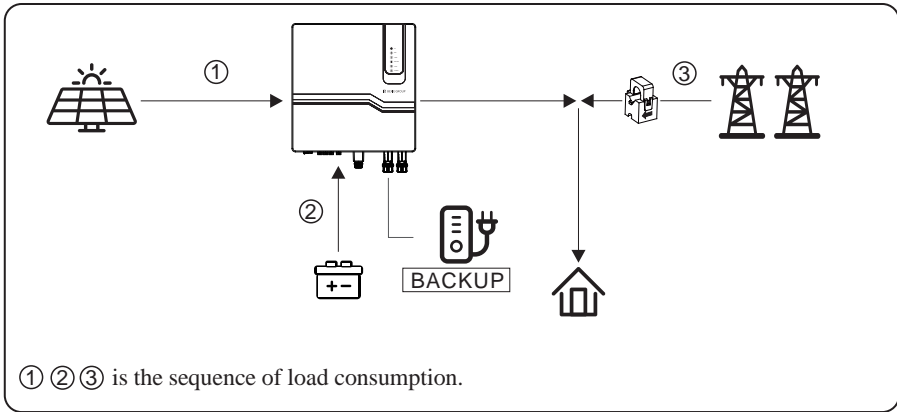

c) No PV Input

The inverter will first discharge the battery energy for home load consuming when no PV input (such as in the evening or some cloudy or rainy days). If the demand is not met, the loads will consume grid energy.

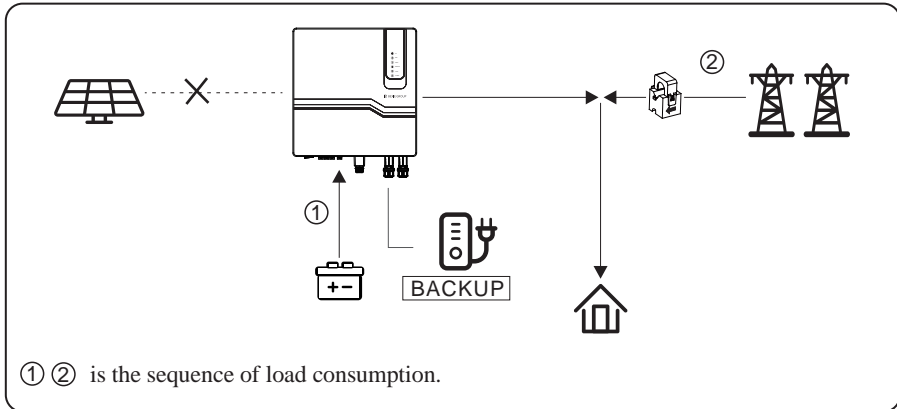

5.1.2 Feed-in Priority Mode

Go to [Console > Hybrid Setting > Work mode](#) page, and select [Feed-in priority mode](#).

Under this mode, the priority of PV energy consumption will be Load > Grid > Battery, that means the energy produced by PV gives priority to powering local loads, the excess energy is fed into the grid, and the remaining energy is used to charge the battery.

a) Wealthy PV Energy

When PV energy is wealthy, the PV energy will be first consumed by loads. If there is excess PV power, the power will be fed into grid. If there is still PV energy left after load consuming and grid feeding, then the remaining PV power will be used to charge the battery.

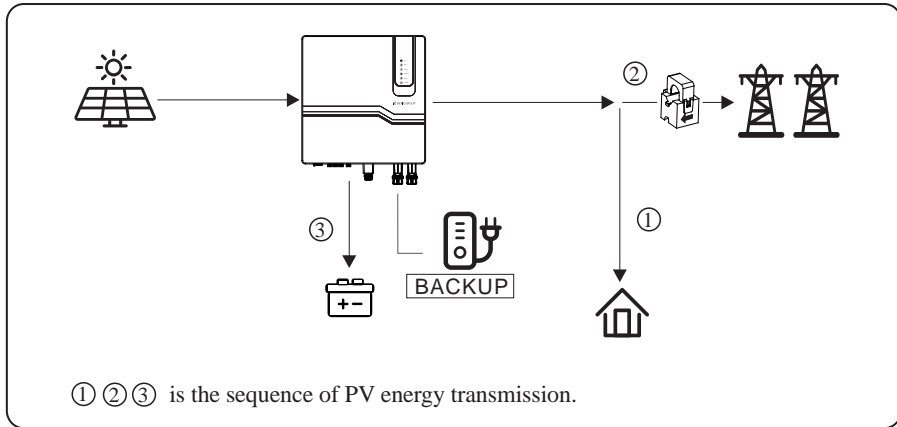

b) Limited PV Energy

When PV energy is limited and can not meet the feed-in grid power, the battery will discharge to meet it.

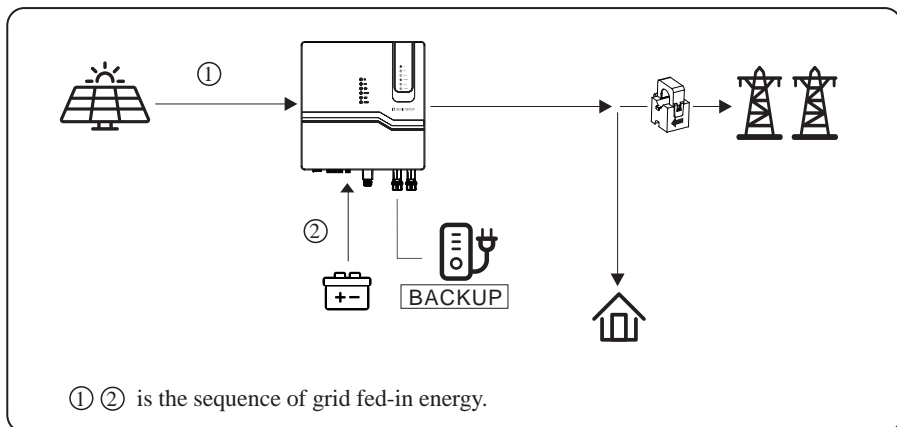

c) No PV Input

The inverter will first discharge the battery energy for home load consuming when no PV input (such as in the evening or some cloudy or rainy days). If the demand is not met, the loads will consume the grid energy.

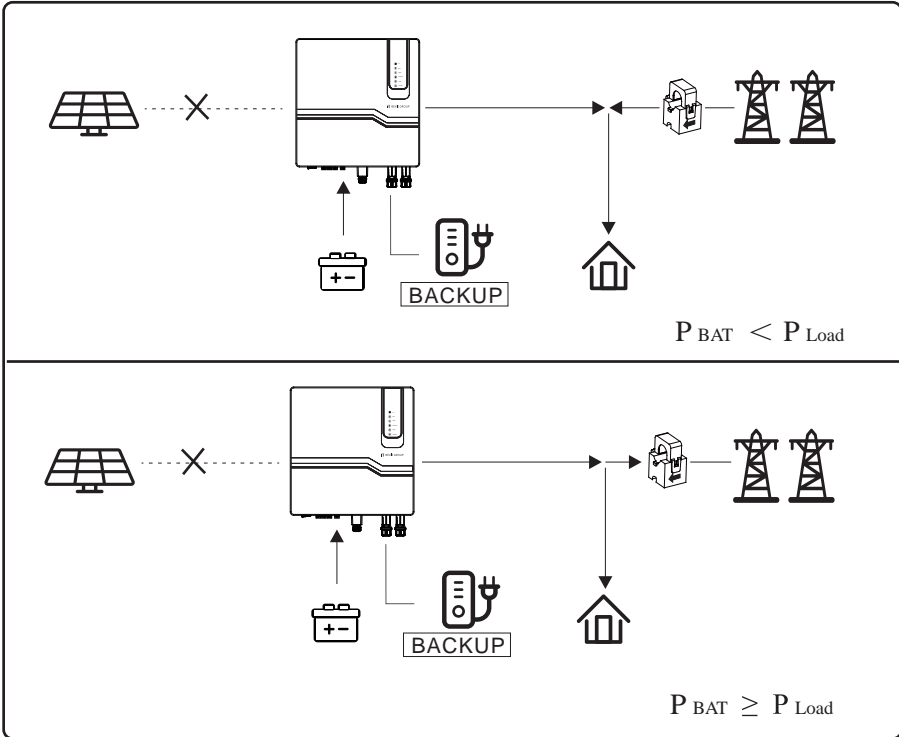

5.1.3 Back-up Mode

Go to [Console > Hybrid Setting > Work mode](#) page, and select [Back-up mode](#).

Under this mode, the priority of PV energy consumption will be Battery > Load > Grid. This mode aims at charging the battery quickly, and at the same time, you can choose whether to allow AC to charge the battery.

Forbid AC charging

In this mode, the battery can be charged only with PV power, and the charging power varies with PV power.

a) Wealthy PV power

When PV energy is wealthy, PV charges the battery first, then meets the load, and the rest is fed into the grid.

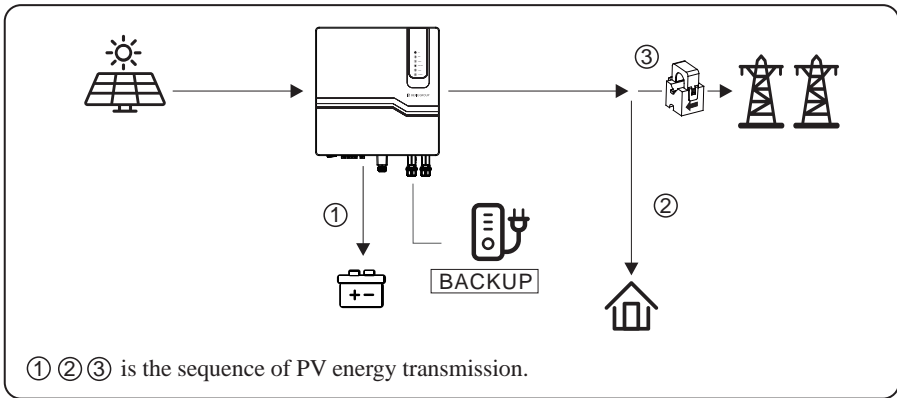

b) Limited PV power

When PV energy is limited, PV gives priority to charging the battery, and the grid directly meet the load demand.

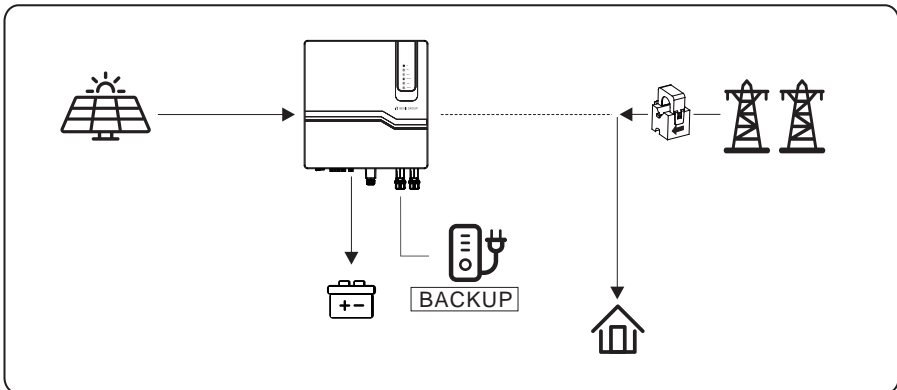

Allow AC charging

In this situation, the battery can be charged both with PV and AC.

a) Wealthy PV power

When PV energy is wealthy, PV charges the battery first, then meets the load, and the rest is fed into the grid.

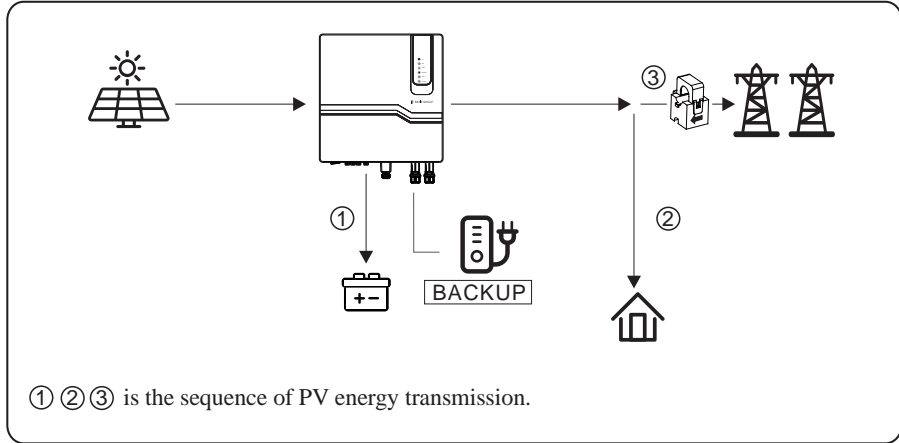

b) Limited PV power

When the PV energy is not enough to charge the battery, the grid energy will charge the battery as supplement. Meanwhile, the grid energy is consumed by loads.

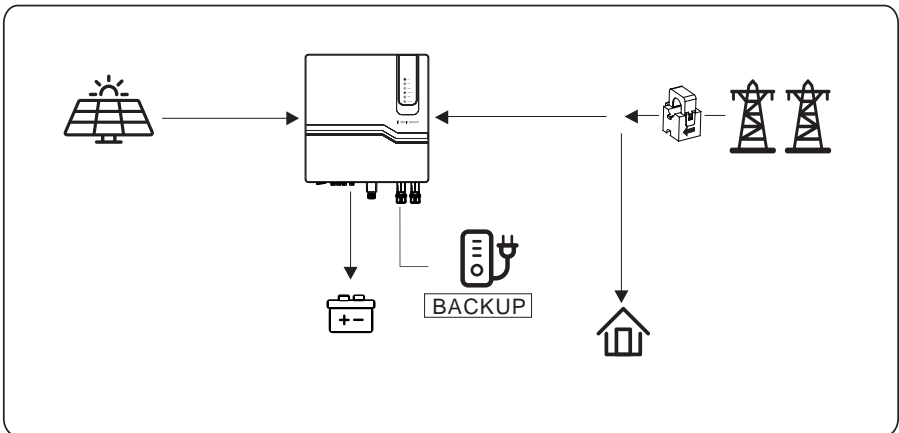

5.1.4 Forced Charge/Discharge Function

According to the demands of application, the user can set the inverter to work on forced charge/discharge the battery in any working mode.

Please go to [Console > Hybrid Setting > Work mode](#) to enable [Time-based Control](#) on APP. There are three time periods in which you can set this function. Outside of the set periods, the inverter returns to its original working mode. The forced charge/discharge function has the highest priority. For setting details, refer to [Work mode](#) in **Console** section.

The relationship between the forced charge/discharge function and working mode shown as below.

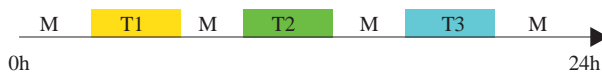

M : Self Use Mode/Feed-in Priority Mode/Back-up Mode

T1: Time period 1 for forced charge/discharge parameter setting

T2: Time period 2 for forced charge/discharge parameter setting

T3: Time period 3 for forced charge/discharge parameter setting

T1, T2, and T3 priority to M.

5.1.5 Off Grid Mode

When the power grid is cut off, the system automatically switches to Off Grid mode. Under off-grid mode, only critical loads are supplied to ensure that important loads continue to work without power failure.

Under this mode, the inverter can't work without the battery.

a) Wealthy PV power

When PV energy is wealthy, the PV power will be first consumed by critical load, then charge the battery.

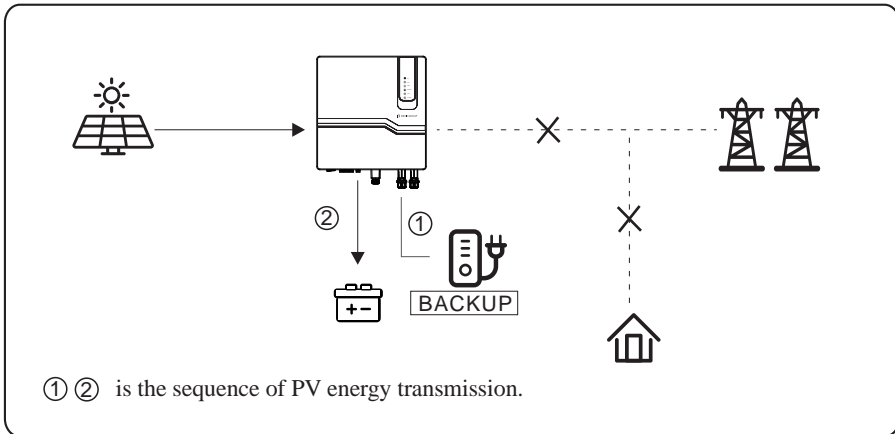

b) Limited PV power

When PV energy is limited, BACKUP loads are first powered by PV and then supplemented by battery.

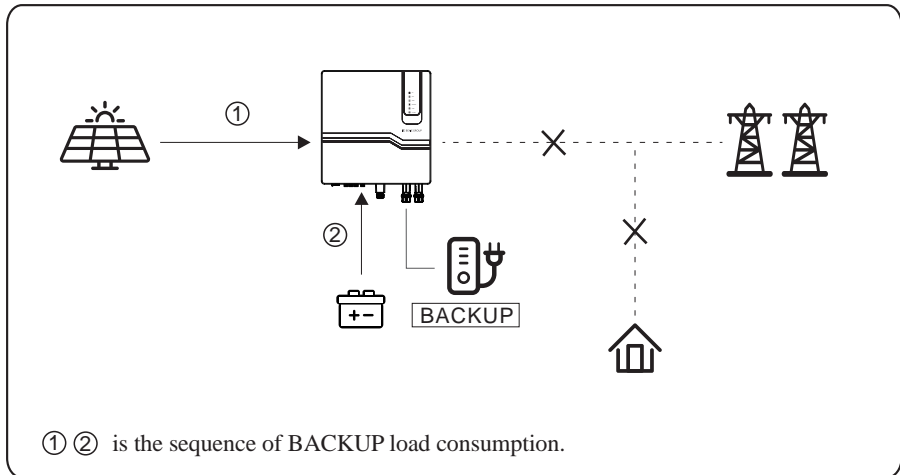

NOTICE

- Under this mode, please complete the output voltage and frequency settings.
- It is better to choose the battery with a capacity larger than 100Ah to ensure BACKUP function work normally.
- If BACKUP output loads are inductive or capacitive loads, to make sure the stability and reliability of system, it is recommended to configure the power of these loads to be within 50% BACKUP output power range.

5.1.6 On-grid Unbalanced Output

- 1) The normal load is single phase.
- 2) The three phases of normal load are the same or unbalanced.

This is the best scheme to meet your needs.

On-grid Unbalanced Output

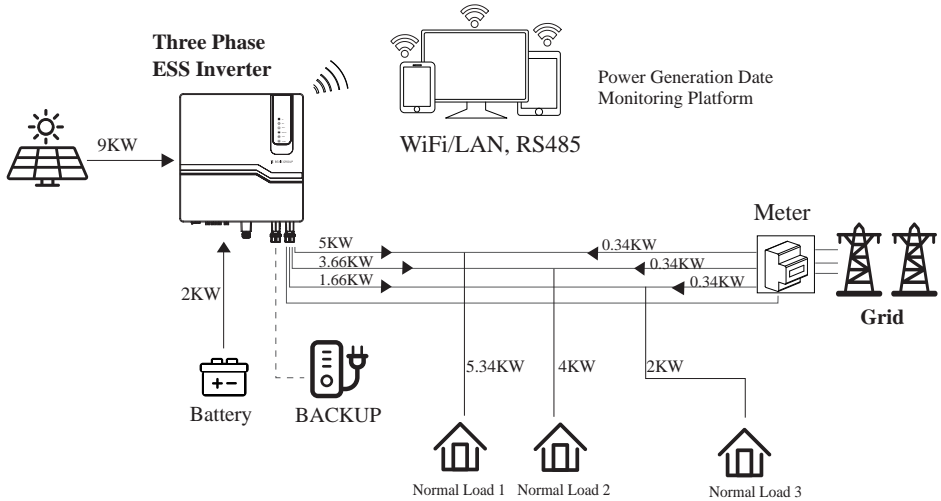

5.1.7 Back-up Unbalanced Output

- 1) The critical load is single phase.
- 2) The three phases of critical load are the same or unbalanced.

This is the best scheme to meet your needs.

Back-up Unbalanced Output

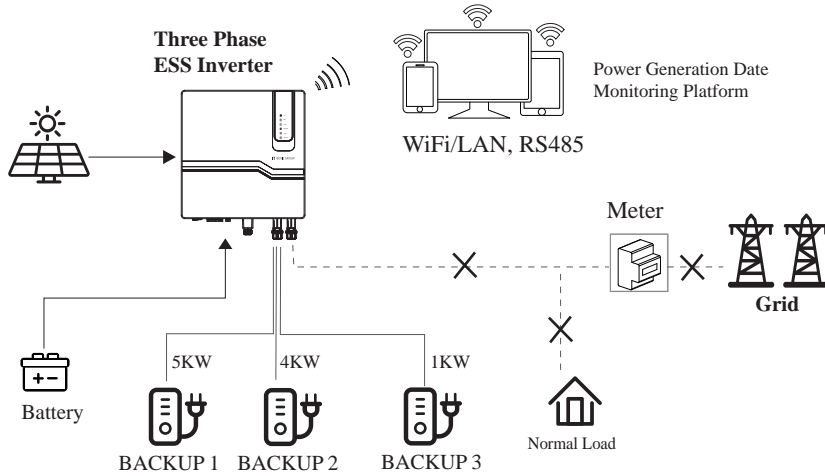

5.2 Startup/Shutdown Procedure

5.2.1 Startup Procedure

Check and confirm the installation is secure and strong enough and that the system grounding is OK. Then confirm the connections of AC, battery, PV etc. are correct. Confirm the parameters and configurations conform to relevant requirements.

AC Frequency	50/60Hz	PV Voltage	160~950V
Battery Voltage	150~600V	Grid AC Voltage	180~270V(311~467V)

Startup Procedure

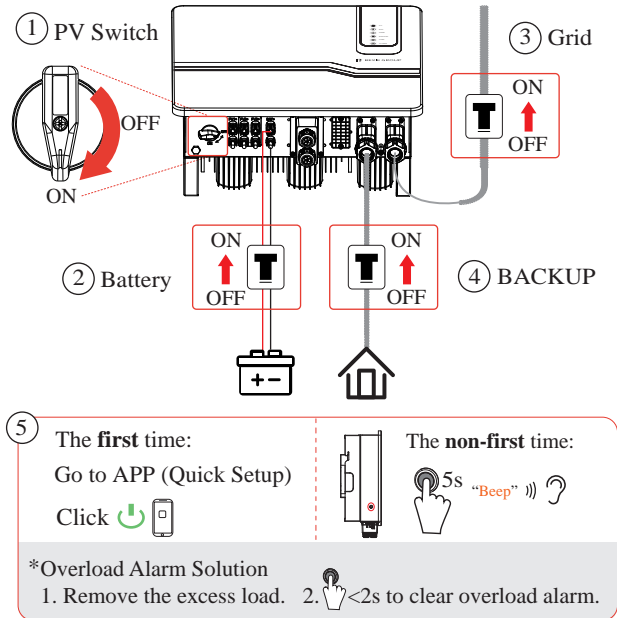

* To act the non-first-time startup, press and hold down the button on the left side of the inverter for about 5 seconds, until you hear the “beep” sound.

Shutdown Procedure

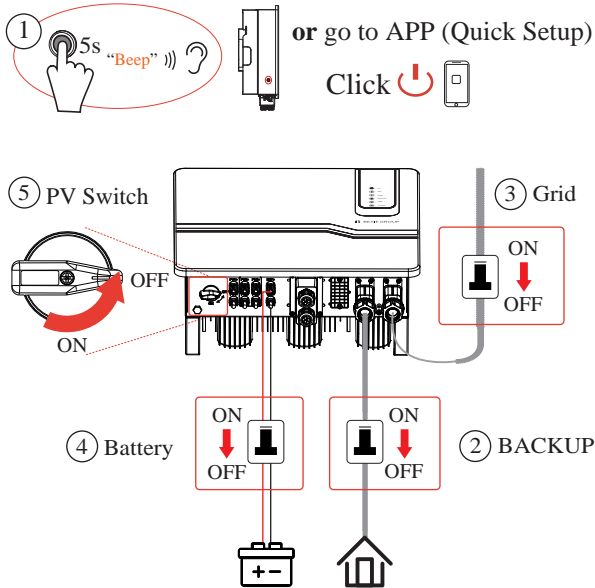

After the inverter is powered off, the remaining electricity and heat may still cause electric shock and body burns. If need to disconnect the inverter cables, please wait at least 10 minutes before touching these parts of inverter.

6. Commissioning

It is necessary to make a complete commissioning of the inverter system. This will essentially protect the system from fire, electric shock or other damages or injuries.

6.1 Inspection

Before commissioning, the operator or installer (qualified personnel) must inspect the system carefully and make sure:

- 1) The system is firmly installed correctly following the contents and notifications of this manual, and there are enough spaces for operation, maintenance and ventilation.
- 2) All the terminals and cables are in good status without any damages.
- 3) No items are left on the inverter or within the required clearance section.
- 4) The PV, battery pack is working normally, and grid is normal.

6.2 Commissioning Procedure

After the inspection and make sure status is right, then start the commissioning of the system.

- 1) Power on the system by referring to the **Startup Procedure** section 5.2.1.
- 2) Setting the parameters on the App according to user's requirement.
- 3) Finish commissioning.

7. User Interface

7.1 LED

This section describes the LED panel. LED indicator includes PV, BAT, GRID, BACKUP, COM, ALARM indicators.

It includes the explanation of indicator states and summary of indicator states under the running state of the machine.



LED Indicator	Status	Description
PV	On	PV input is normal.
	Blink	PV input is abnormal.
	Off	PV is unavailable.
BAT	On	Battery is charging.
	Blink	Battery is discharging (light on 2s and off 2s). Battery is abnormal (light on 1s and off 1s).
	Off	Battery is unavailable.
GRID	On	GRID is available and normal.
	Blink	GRID is abnormal.
	Off	GRID is unavailable.
BACKUP	On	BACKUP power is available.
	Blink	BACKUP output is abnormal.
	Off	BACKUP power is unavailable.
COM	Blink	Data are communicating.
	Off	No data transmission
ALARM	On	Fault has occurred and inverter shuts down.
	Blink	Alarms has occurred but inverter doesn't shut down.
	Off	No fault.

Details	Code	PV LED	Grid LED	BAT LED	BACKUP LED	COM LED	ALARM LED
PV normal		●	⊙	⊙	⊙	⊙	○
No PV		○	⊙	⊙	⊙	⊙	○
PV over voltage	B0						
PV under voltage	B4						
PV irradiation weak	B5	★	⊙	⊙	⊙	⊙	○
PV string reverse	B7						
PV string abnormal	B3						
On grid							
Bypass output		⊙	●	⊙	⊙	⊙	○
Grid over voltage	A0						
Grid under voltage	A1						
Grid absent	A2						
Grid over frequency	A3	⊙	★	⊙	⊙	⊙	○
Grid under frequency	A4						
Grid abnormal	A6						
Grid over mean voltage	A7						
Neutral live wire reversed	A8						
Battery in charger		⊙	⊙	●	⊙	⊙	○
Battery absent	D1	⊙	⊙	○	⊙	⊙	○
Battery in discharge		⊙	⊙	★★	⊙	⊙	○
Battery under voltage	D3						
Battery over voltage	D2						
Battery discharge over current	D4	⊙	⊙	★	⊙	⊙	○
Battery over temperature	D5						
Battery under temperature	D6						
Communication loss (Inverter - BMS)	D8						
BACKUP output active		⊙	⊙	⊙	●	⊙	⊙
BACKUP output inactive		⊙	⊙	⊙	○	⊙	⊙
BACKUP short circuit	DB						
BACKUP over load	DC						
BACKUP output voltage abnormal	D7	⊙	⊙	⊙	★	⊙	○
BACKUP over dc-bias voltage	CP						

Details	Code	PV LED	Grid LED	BAT LED	BACKUP LED	COM LED	ALARM LED
RS485/DB9/BLE/USB		⊙	⊙	⊙	⊙	★	⊙
Inverter over temperature	C5						
Fan abnormal	C8						
Inverter in power limit state	CL						
Data logger lost	CH	⊙	⊙	⊙	⊙	⊙	★
Meter lost	CJ						
Remote off	CN						
PV insulation abnormal	B1						
Leakage current abnormal	B2						
Internal power supply abnormal	C0						
Inverter over dc-bias current	C2						
Inverter relay abnormal	C3						
GFCI abnormal	C6						
System type error	C7						
Unbalance Dc-link voltage	C9						
Dc-link over voltage	CA	⊙	⊙	⊙	⊙	⊙	●
Internal communication error	CB						
Internal communication loss(E-M)	D9						
Internal communication loss(M-D)	DA						
Software incompatibility	CC						
Internal storage error	CD						
Data inconsistency	CE						
Inverter abnormal	CF						
Boost abnormal	CG						
Dc-dc abnormal	CU						

Remark: ● Light on ○ Light off ⊙ Keep original status
 ★ Light on 1s and off 1s ★★ Light on 2s and off 2s

7.2 App Setting Guide

7.2.1 App Architecture

It contains “Cloud Login” and “Local Login”.

- Cloud login: APP read data from cloud server through API and display inverter parameter
- Local login: APP read data from inverter through Bluetooth connection with Modbus protocol to display and configure inverter parameter.

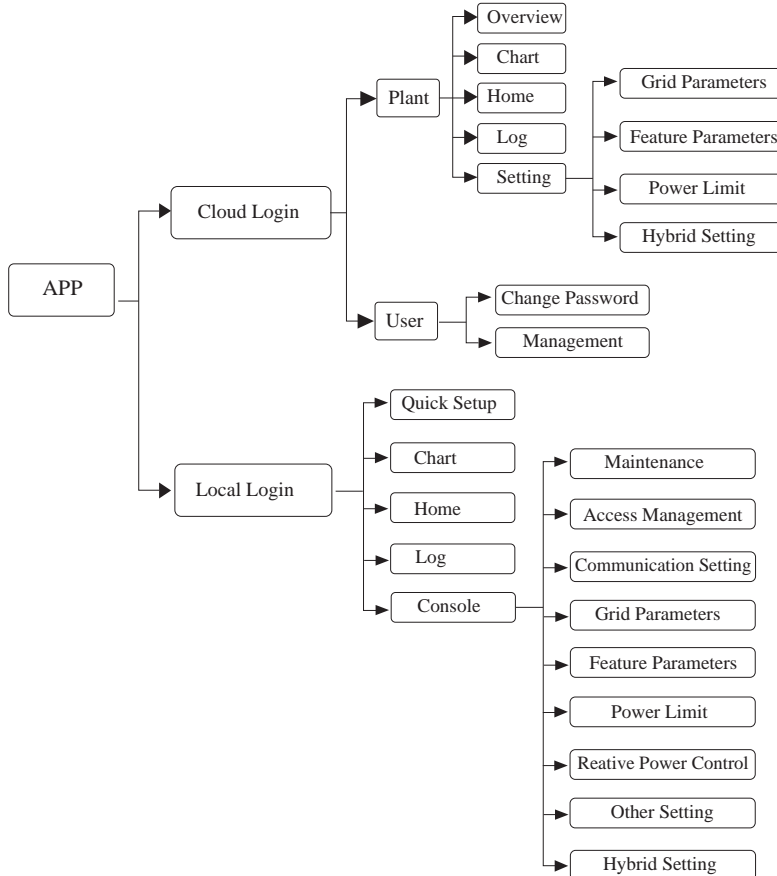

7.2.2 Download App

- Scan the QR code on the inverter to download the APP.
- Download APP from the App Store or Google Play.

 Note:

The APP should access some permissions such as the device’s location. You need to grant all access rights in all pop-up windows when installing the APP or setting your phone.

7.2.3 Local Login

Step 1. Open the Bluetooth on your own phone and the APP, then click the **Bluetooth Connection**.

Step 2. To connect the inverter, please choose one of the following three ways:

- Scan machine SN barcode
- Enter SN
- Manual connection

Step 3. Click **OK**.

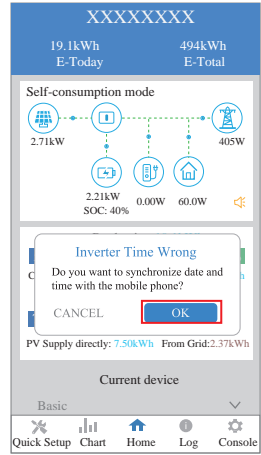
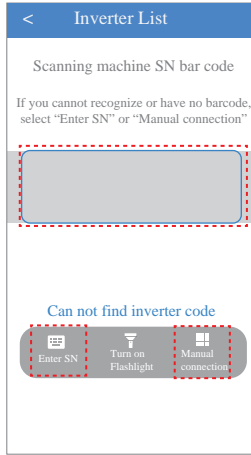
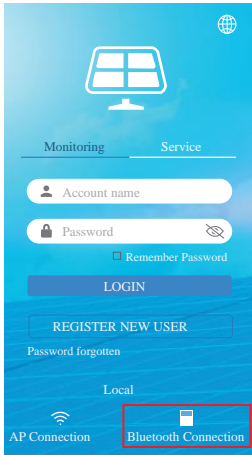

▪ **Quick Setup**

The quick setup is required for the first local login.

Step 1. Click the **Quick Setup**.

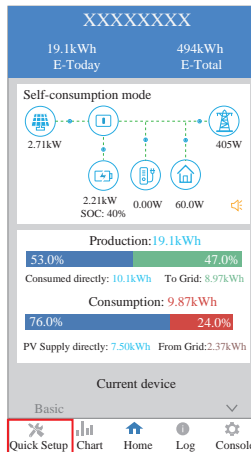

Step 2. Firstly please read tips on the screen carefully. Secondly choose the WiFi SSID and enter the WiFi password. Then click the **START THE CONFIGURATION** button and wait for WiFi router loading successfully. Finally click the **Next**.

 Note:

Please use the 2.4G network frequency band for configuration.

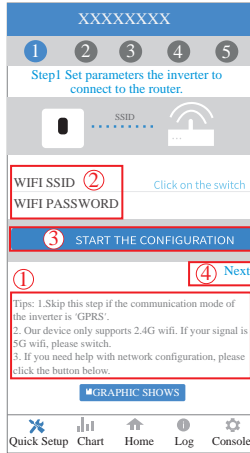

Step 3. Set **Standard Code** and **Date and Time** parameters. Then click the **Next**.

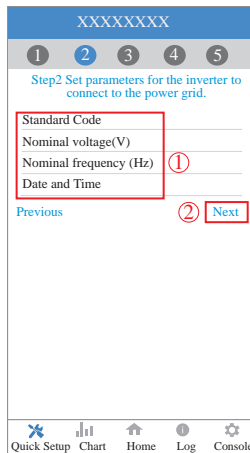

Step 4. Set parameters for the inverter to connect to the power limit. Then click the **Next**.

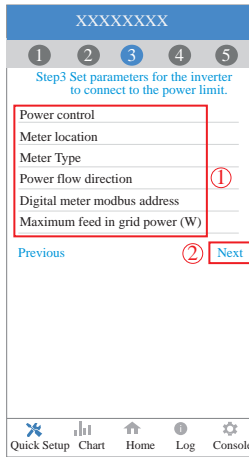

Step 5. Set parameters for the inverter to connect to the work mode and battery type. Then click the **Next**.

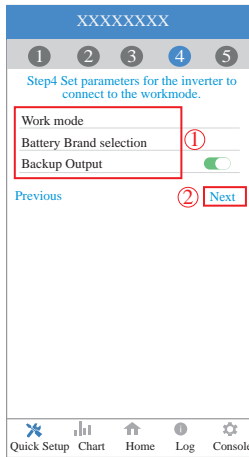

Step 6. Please click the button to turn on the inverter.

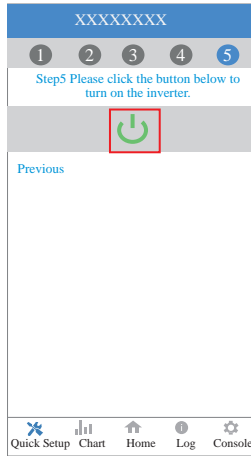

▪ **Chart**

The power chart is showed by Day, Month and Year in our APP. Data curves in the following figures are only for illustration.

Query Daily Data

Go to [Chart > Day](#) page. It will show the Daily Production or Consumption Curve in this page. You can click anywhere on the graph to see the energy value of any time.



The above combination day chart shows the energy flow:

- PV generation power (Blue)
- battery discharge and charge power (Red)
- grid power and feed-in grid power (Purple)
- load consumption power (Orange)

Query Monthly Data

Go to [Chart](#) > [Month](#) page. It will show the Monthly Production or Consumption Curve in this page. You can click anywhere on the graph to see the energy value of any month.

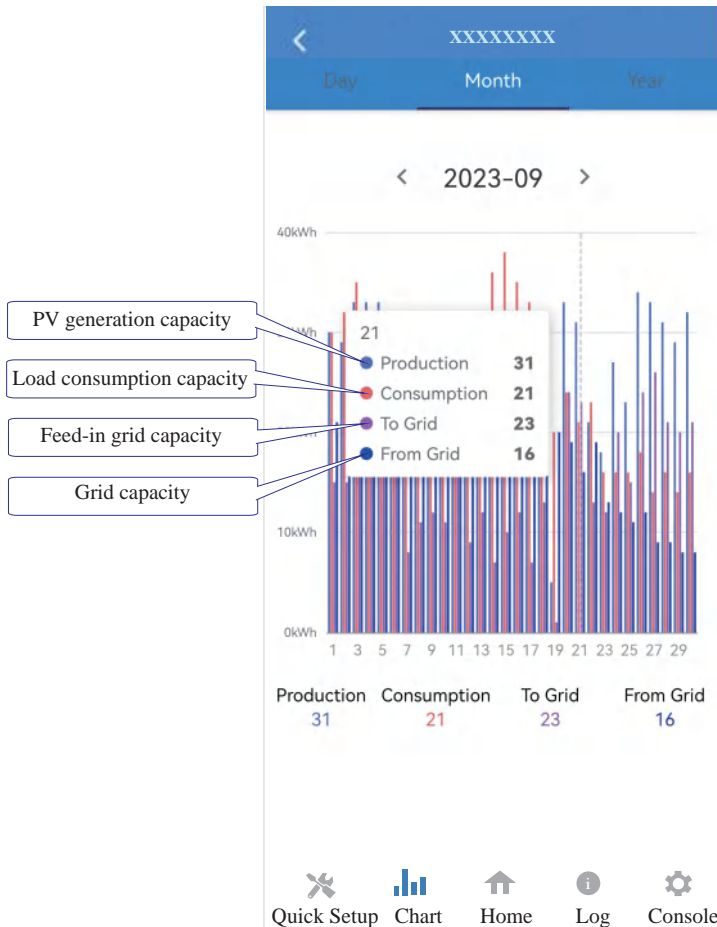

The above combination month chart shows the the energy flow:

- PV generation capacity (Blue)
- load consumption capacity (Red)
- feed-in grid capacity (Purple)
- grid capacity (Mazarine)

Query Yearly Data

Go to **Chart > Year** page. It will show the Annually Production or Consumption Curve in this page. You can click anywhere on the graph to see the energy value of any year.

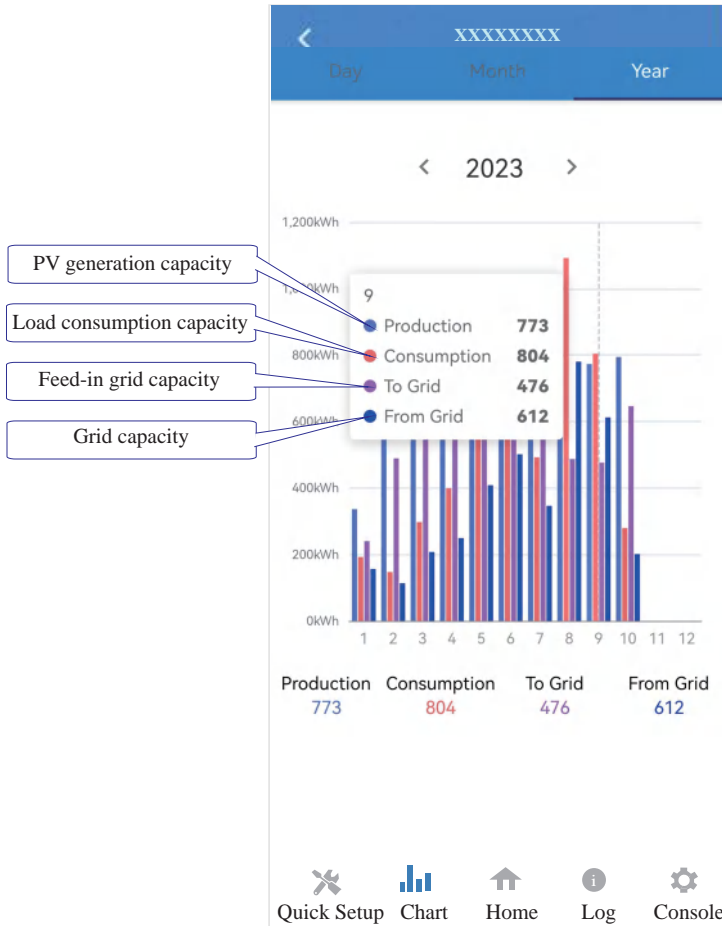

The above combination year chart shows the the energy flow:

- PV generation capacity (Blue)
- load consumption capacity (Red)
- feed-in grid capacity (Purple)
- grid capacity (Mazarine)

▪ **Home**

In this page, you can view the basic information of inverter.
Click  to display the warning message.

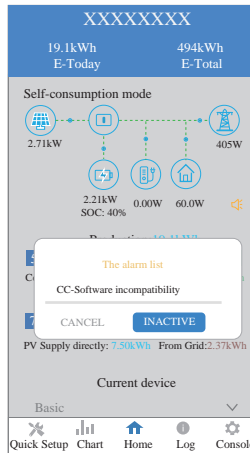
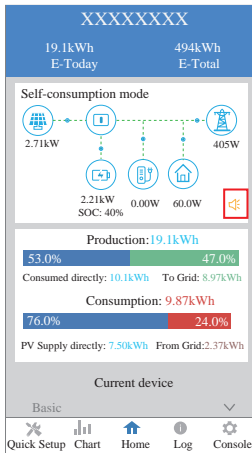

▪ **Log**

Press **Log** at the bottom and then go to the history log page (as shown below). It contains all the logs for the inverter.

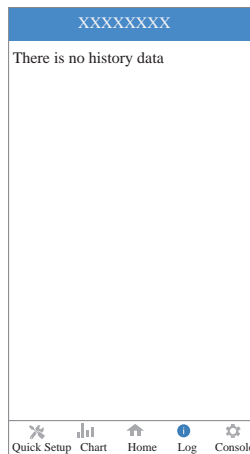
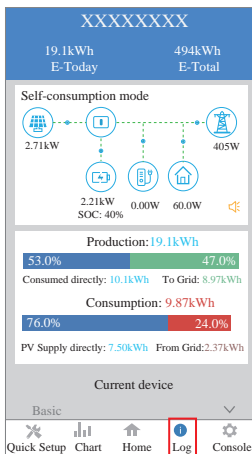

▪ **Console**

In this page, you can view the basic information like some version information, do some maintaining operations like turn off/on the inverter and manage data.

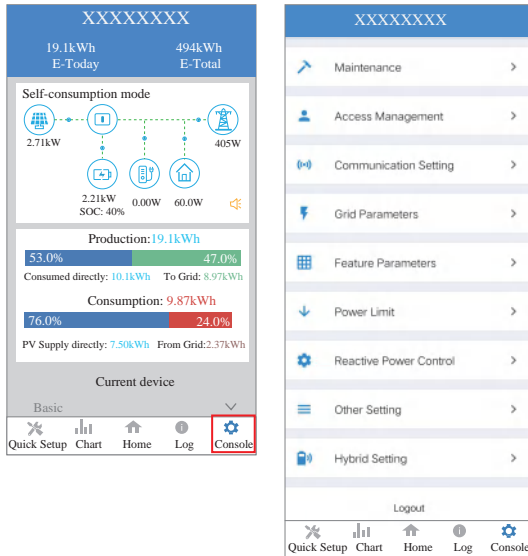

Maintenance

In this page, you can do some maintaining operations like turn off/on the inverter and manage data.

In [Console](#) page, click [Maintenance](#).

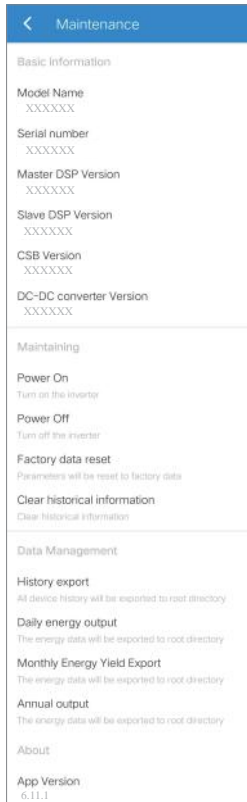

Access Management

In this page, you can switch the login permission.

In [Console](#) page, click [Access Management](#) > [Change User](#) page.

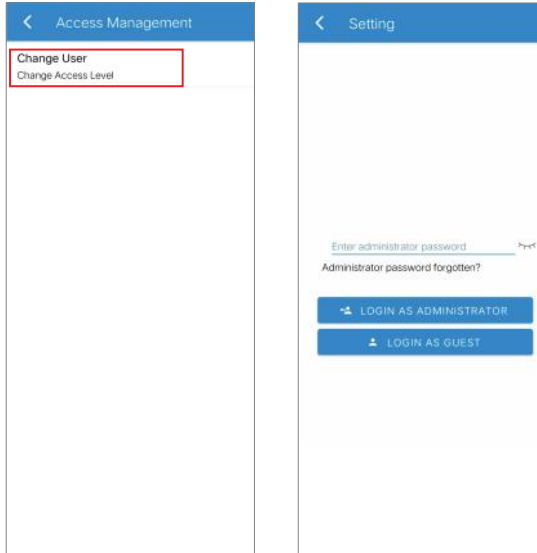

Communication Setting

In this page, you can set or change the parameters of communication settings: WiFi Setting, RS485 Setting and Ethernet Setting.

In [Console](#) page, click [Communication Setting](#).

 Note:

Setting/modifying these parameters requires logging into an administrator account.



Grid Parameters

In this page, you can set or change the parameters of Grid side.

In [Console](#) page, click [Grid Parameters](#).

 Note:

Setting/modifying these parameters requires logging into an administrator account.

<
Grid Parameters

Standard Code	IN (IEC61727)
First Connect Delay Time(s)	60
Reconnect Delay Time (s)	60
First Connect Power Gradient(%/min)	100
Reconnect Power Gradient(%/min)	100
Frequency High Loss Level_1(Hz)	51
Frequency Low loss Level_1(Hz)	49
Voltage High Loss Level_1(V)	253
Voltage Low Loss Level_1(V)	195.5
Frequency High Loss Time Level_1(ms)	100
Frequency Low loss Time Level_1(ms)	100
Voltage High Loss Time Level_1(ms)	200
Voltage Low Loss Time Level_1(ms)	200
Frequency High Loss Level_2(Hz)	99.9
Frequency Low Loss Level_2 (Hz)	10
Voltage High Loss Level_2(V)	310.5
Voltage Low Loss Level_2(V)	115
Frequency High Loss Time Level_2(ms)	65535
Frequency Low Loss Time Level_2(ms)	65535
Voltage High Loss Time Level_2(ms)	50
Voltage Low Loss Time Level_2(ms)	100
Over Frequency Derating Function	<input checked="" type="checkbox"/>
Over Frequency Power Reduction Droop(%)	5
Grid Over Frequency de-rating Start Point(Hz)	50.2
Over Frequency Derating Reference Power	base on current power
Over Voltage Derating	<input type="checkbox"/>

Feature Parameters

In this page, you can set or change the feature parameters, as shown in the figure.

In [Console](#) page, click [Feature Parameters](#).



Note:

Setting/modifying these parameters requires logging into an administrator account.



Power Limit

In this page, you can set or change the parameters of power limit.

In [Console](#) page, click [Power Limit](#) page.



Note:

Setting/modifying these parameters requires logging into an administrator account.



Reactive Power Control

In this page, you can set or change the Reactive Power Control parameters.

In [Console](#) page, click [Reactive Power Control](#).

 Note:

Setting/modifying these parameters requires logging into an administrator account.



How to Autotest?

Step 1. In **Console** page, click **Grid Parameters > Standard Code**, then select the IT (CEI 0-21) or IT (CEI O-21 ACEA).

Step 2. Back to **Console** page. Refresh the page and enter the **Autotest** page to click **START**.

Step 3. Then the inverter is autotesting. Wait for about 10 minutes, the autotest process will be finished.

Step 4. You can click the **DOWNLOAD** to save the data file if necessary.

 Note: If the **Autotest** option can't be turned out after the refresh in step 2. Please re-connect after logout. And then go to **Console > Autotest** page to click **START**.

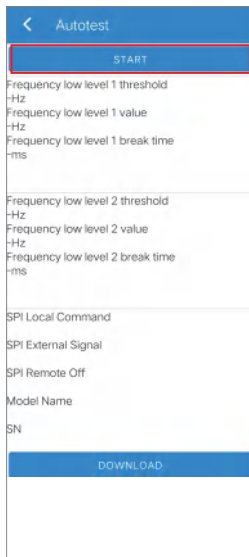
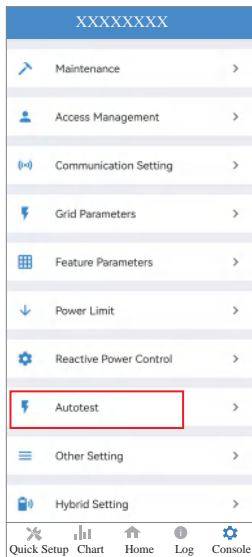
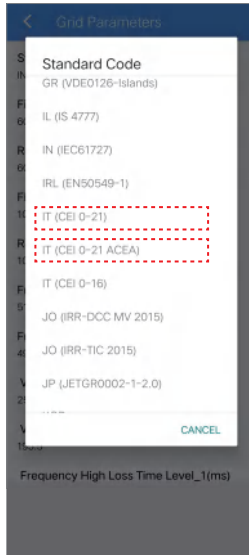

Other Setting

In this page, you can set other setting parameters.

In [Console](#) page, click [Other Setting](#).



Enable [DRM Function](#)
When the DRMs set up.

Hybrid Setting

In this page, you can set Hybrid Setting parameters.

In [Console](#) page, click [Hybrid Setting](#).

 Note:

Setting/modifying these parameters requires logging into an administrator account.



- Work mode

- Work mode: In [Work mode](#) page, there are several work modes are available.

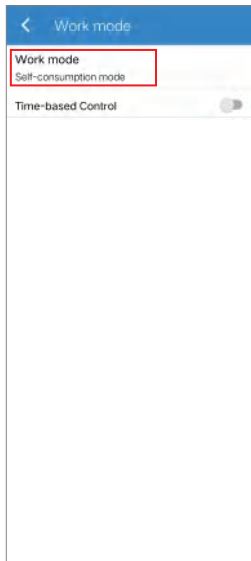

►Time-based Control setting: In **Work mode** page, you can also find time-based control function. This function is designed to control the time setting of charging and discharging the inverter. You can set the following parameters based on your requirements:

- Charge and discharge frequency: one time or daily
- Charging start time: 0 to 24 hours
- Charging end time: 0 to 24 hours
- Discharge start time: 0 to 24 hours
- Discharge end time: 0 to 24 hours

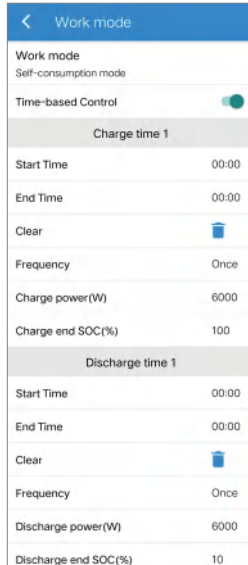
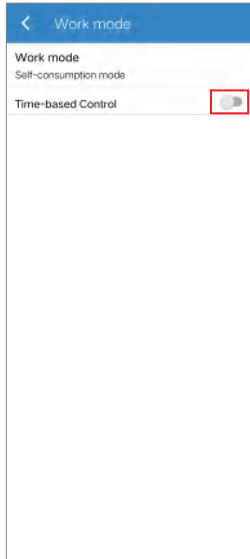

- Battery

In **Battery** page, information including battery parameters, charging and discharging management and grid will be listed. Enter corresponding information if necessary.

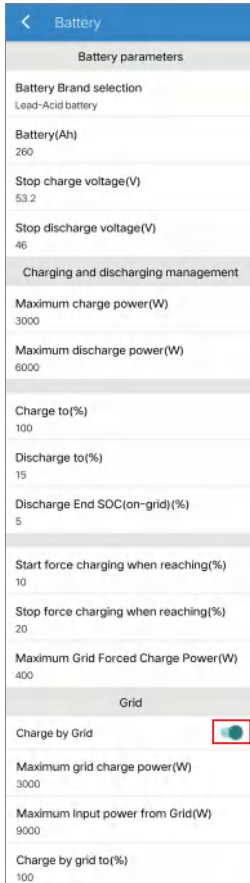

Battery parameters	
Battery Brand selection	Lead-Acid battery
Battery(Ah)	260
Stop charge voltage(V)	53.2
Stop discharge voltage(V)	46
Charging and discharging management	
Maximum charge power(W)	3000
Maximum discharge power(W)	6000
Charge to(%)	100
Discharge to(%)	15
Discharge End SOC(on-grid)(%)	5
Start force charging when reaching(%)	10
Stop force charging when reaching(%)	20
Maximum Grid Forced Charge Power(W)	400
Grid	
Charge by Grid	<input checked="" type="checkbox"/>
Maximum grid charge power(W)	3000
Maximum input power from Grid(W)	9000
Charge by grid to(%)	100

Choose whether to allow the grid to charge the battery, which is prohibited by default. When the battery capacity or voltage reaches the set value, the grid will stop charging the battery.

User Interface

- Backup Load

In **Backup Load** page, if enabling Backup Output, you can set parameters including the range of backup output voltage and Min. initiation/startup battery capacity when off-grid.

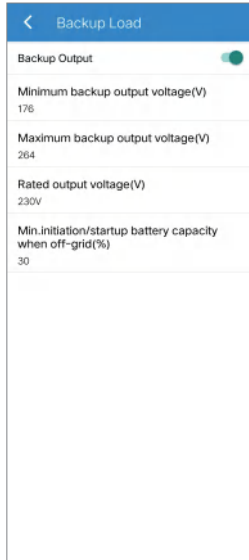

- Other

In **Other** page, options including Parallel mode, Buzzer ON, Support Normal Load are listed. Enable them when necessary.

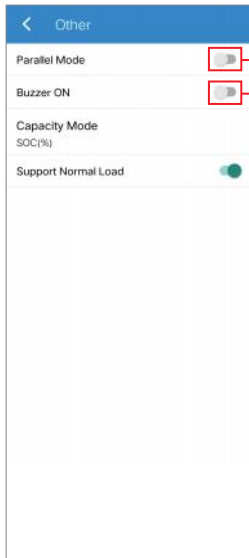

Enable **Parallel mode** when the parallel system set up.

Enable **Buzzer On** to open the Buzzer function.

8. Maintenance

 CAUTION	<p>Before maintaining and commissioning inverter and its peripheral distribution unit, switch off all the charged terminals of the inverter and wait at least 10 minutes after the inverter is powered off.</p>
--	---

8.1 Routine Maintenance

Items	Check Content	Maintain Content	Maintenance Interval
Inverter output status	Statistically maintain the status of electrical yield, and remotely monitor its abnormal status.	N/A	Weekly
Inverter cleaning	Check periodically that the heat sink is free from dust and blockage.	Clean periodically the heat sink.	Yearly
Inverter running status	Check that the inverter is not damaged or deformed. Check for normal sound emitted during inverter operation. Check and ensure that all inverter communications is running well.	If there is any abnormal phenomenon, replace the relevant parts.	Monthly
Inverter electrical connections	Check that all AC, DC and communication cables are securely connected; Check that PGND cables are securely connected; Check that all cables are intact and free from aging.	If there is any abnormal phenomenon, replace the cable or re-connect it.	Semiannually

8.2 Inverter Troubleshooting

When the inverter has an exception, its basic common warning and exception handling methods are shown below.

Code	Alarm Information	Suggestions
A0	Grid over voltage	<ol style="list-style-type: none"> 1. If the alarm occurs occasionally, possibly the power grid voltage is abnormal for a short time, and no action is required. 2. If the alarm occurs repeatedly, contact the local power station. After receiving approval of the local power bureau, revise the electrical protection parameters settings on the inverter through the App. 3. If the alarm persists for along time, check whether the AC circuit breaker /AC terminals is disconnected or not, or if the grid has a power outage.
A1	Grid under voltage	
A3	Grid over frequency	
A4	Grid under frequency	
A2	Grid absent	Wait till power is restored.
B0	PV over voltage	Check whether the maximum voltage of a single string of input PV modules is greater than the allowable voltage. If the maximum voltage is higher than the standard voltage, modify the number of pv module connection strings.
B1	PV insulation abnormal	<ol style="list-style-type: none"> 1. Check the insulation resistance against the ground for the PV strings. If a short circuit has occurred, rectify the fault. 2. If the insulation resistance against the ground is less than the default value in a rainy environment, set insulation resistance protection on the App.
B2	Leakage current abnormal	<ol style="list-style-type: none"> 1. If the alarm occurs occasionally, the inverter can be automatically recovered to the normal operating status after the fault is rectified. 2. If the alarm occurs repeatedly, contact your dealer for technical support.
B4	PV under voltage	<ol style="list-style-type: none"> 1. If the alarm occurs occasionally, possibly the external circuits are abnormal accidentally. The inverter automatically recovers to the normal operating status after the fault is rectified. 2. If the alarm occurs repeatedly or last a long time, check whether the insulation resistance against the ground of PV strings is too low.
C0	Internal power supply abnormal	<ol style="list-style-type: none"> 1. If the alarm occurs occasionally, the inverter can be automatically restored, no action required. 2. If the alarm occurs repeatedly, pls. contact the customer service center.

C2	Inverter over dc-bias current	<ol style="list-style-type: none"> 1. If the alarm occurs occasionally, possibly the power grid voltage is abnormal for a short time, and no action is required. 2. If the alarm occurs repeatedly, and the inverter fails to generate power, contact the customer service center.
C3	Inverter relay abnormal	<ol style="list-style-type: none"> 1. If the alarm occurs occasionally, possibly the power grid voltage is abnormal for a short time, and no action is required. 2. If the alarm occurs repeatedly, pls. refer to the suggestions or measures of Grid over voltage. and the inverter fails to generate power, contact the customer service center. If there is no abnormality on the grid side, the machine fault can be determined. (If you open the cover and find traces of damage to the relay, it can be concluded that the machine is faulty.) And pls. contact the customer service center.
CN	Remote off	<ol style="list-style-type: none"> 1. Local manual shutdown is performed in APP. 2. The monitor executed the remote shutdown instruction. 3. Remove the communication module and confirm whether the alarm disappears. If it does, replace the communication module. Otherwise, please contact the customer service center.
C5	Inverter over temperature	<ol style="list-style-type: none"> 1. If the alarm occurs occasionally, the inverter can be automatically restored, no action required. 2. If the alarm occurs repeatedly, pls. check the installation site for direct sunlight, good ventilation, and high ambient temperature (Such as installed on the parapet). If the ambient temperature is lower than 45 ° C and the heat dissipation is good, contact the customer service center.
C6	GFCI abnormal	<ol style="list-style-type: none"> 1. If the alarm occurs occasionally, it could have been an occasional exception to the external wiring, the inverter can be automatically recovered, no action required. 2. If it occurs repeatedly or cannot be recovered for a long time, pls. contact customer service to report repair.
B7	PV string reverse	Check and modify the positive and negative polarity of the input of the circuit string.
C8	Fan abnormal	<ol style="list-style-type: none"> 1. If the alarm occurs occasionally, pls. restart the inverter. 2. If it occurs repeatedly or cannot be recovered for a long time, check whether the external fan is blocked by foreign objects. Otherwise, contact customer service.
C9	Unbalance Dc-link voltage	1. If the alarm occurs occasionally, the inverter can be automatically recovered and no action is required.
CA	Dc-link over voltage	2. If the alarm occurs repeatedly, the inverter cannot work properly. Pls. contact the customer service center.

CB	Internal communication error	<ol style="list-style-type: none"> 1. If the alarm occurs occasionally, the inverter can be automatically recovered and no action is required. 2. If the alarm occurs repeatedly, the inverter cannot work properly. Pls. contact the customer service center.
CC	Software incompatibility	<ol style="list-style-type: none"> 1. If the alarm occurs occasionally, the inverter can be automatically recovered and no action is required. 2. If the alarm occurs repeatedly, the inverter cannot work properly. Pls. contact the customer service center.
CD	Internal storage error	<ol style="list-style-type: none"> 1. If the alarm occurs occasionally, the inverter can be automatically recovered and no action is required. 2. If the alarm occurs repeatedly, the inverter cannot work properly. Pls. contact the customer service center.
CE	Data inconsistency	<ol style="list-style-type: none"> 1. If the alarm occurs occasionally, the inverter can be automatically recovered and no action is required. 2. If the alarm occurs repeatedly, the inverter cannot work properly. Pls. contact the customer service center.
CF	Inverter abnormal	<ol style="list-style-type: none"> 1. If the alarm occurs occasionally, the inverter can be automatically recovered and no action is required. 2. If the alarm occurs repeatedly, the inverter cannot work properly. Pls. contact the customer service center.
CG	Boost abnormal	<ol style="list-style-type: none"> 1. If the alarm occurs occasionally, the inverter can be automatically recovered and no action is required. 2. If the alarm occurs repeatedly, the inverter cannot work properly. Pls. contact the customer service center.
CJ	Meter lost	<ol style="list-style-type: none"> 1. Check the meter parameter Settings 2. Local APP checks that the communication address of the inverter is consistent with that of the electricity meter 3. The communication line is connected incorrectly or in bad contact 4. electricity meter failure. 5. Exclude the above, if the alarm continues to occur, please contact the customer service center.

D2	Battery over voltage	<ol style="list-style-type: none"> 1. If the alarm occurs occasionally, the inverter can be automatically recovered and no action is required. 2. Check that the battery overvoltage protection value is improperly set. 3. The battery is abnormal. 4. If exclude the above, the alarm continues to occur, please contact the customer service center.
D3	Battery under voltage	<ol style="list-style-type: none"> 1. If the alarm occurs occasionally, the inverter can be automatically recovered and no action is required. 2. Check the communication line connection between BMS and inverter (lithium battery). 3. The battery is empty or the battery voltage is lower than the SOC cut-off voltage. 4. The battery undervoltage protection value is improperly set. 5. The battery is abnormal. 6. If exclude the above, the alarm continues to occur, please contact the customer service center.
D4	Battery discharger over current	<ol style="list-style-type: none"> 1. Check whether the battery parameters are correctly set. 2. Battery undervoltage. 3. Check whether a separate battery is loaded and the discharge current exceeds the battery specifications. 4. The battery is abnormal. 5. If exclude the above, the alarm continues to occur, please contact the customer service center.
D5	Battery over temperature	<ol style="list-style-type: none"> 1. If the alarm occurs repeatedly, please check whether the installation site is in direct sunlight and whether the ambient temperature is too high (such as in a closed room).
D6	Battery under temperature	<ol style="list-style-type: none"> 2. If the battery is abnormal, replace it with a new one. 3. If exclude the above, the alarm continues to occur, please contact the customer service center.
D7	BACKUP output voltage abnormal	<ol style="list-style-type: none"> 1. Check whether the BACKUP voltage and frequency Settings are within the specified range. 2. Check whether the BACKUP port is overloaded. 3. When not connected to the power grid, check whether output is normal. 4. If exclude the above, the alarm continues to occur, please contact the customer service center.
D8	Communication error (Inverter-BMS)	<ol style="list-style-type: none"> 1. Check whether the battery is disconnected. 2. Check whether the battery is well connected with the inverter. 3. Confirm that the battery is compatible with the inverter. It is recommended to use CAN communication. 4. Check whether the communication cable or port between the battery and the inverter is faulty. 5. If exclude the above, the alarm continues to occur, please contact the customer service center.



D9	Internal communication loss(E-M)	1. Check whether the communication cables between BACKUP, electricity meter and inverter are well connected and whether the wiring is correct 2. Check whether the communication distance is within the specification range
DA	Internal communication loss(M-D)	3. Disconnect the external communication and restart the electricity meter and inverter. 4. If exclude the above, the alarm continues to occur, please contact the customer service center.
CU	Dcdc abnormal	1. If the alarm occurs occasionally, the inverter can be automatically recovered and no action is required. 2. If the alarm occurs repeatedly, please check: 1) Check whether the MC4 terminal on the PV side is securely connected. 2) Check whether the voltage at the PV side is open circuit, ground to ground, etc. If exclude the above, the alarm continues to occur, please contact the customer service center.
CP	BACKUP over dc-bias voltage	1. If the alarm occurs occasionally, the inverter can be automatically recovered and no action is required. 2. If the alarm occurs repeatedly, the inverter cannot work properly. Pls. contact the customer service center.
DB	BACKUP short circuit	1. Check whether the live line and null line of BACKUP output are short-circuited. 2. If it is confirmed that the output is not short-circuited or an alarm, please contact customer service to report for repair. (After the troubleshooting of alarm problems, BACKUP switch needs to be manually turned on during normal use.)
DC	BACKUP over load	1. Disconnect the BACKUP load and check whether the alarm is cleared 2. If the load is disconnected and the alarm is generated, please contact the customer service. (After the alarm is cleared, the BACKUP switch needs to be manually turned on for normal use.)

8.3 Removing the Inverter

 WARNING	Before removing DC input connector, double check DC input switch is turned to OFF to avoid inverter damage and personal injury.
--	---

Perform the following procedures to remove the inverter:

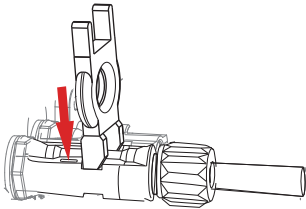
Step 1. Disconnect all cables from the inverter, including communications cables, DC input power cables, AC output power cables, and PGND cable, as shown below.

<p>PV Connectors Removing Detail</p> 	<p> NOTE</p> <p>To remove the PV connectors, insert the removal tool into the bayonet according to the position indicated in the drawing, press inward, and then take out the connector outward.</p>
---	--

GRID/BACKUP Connectors Removing Detail

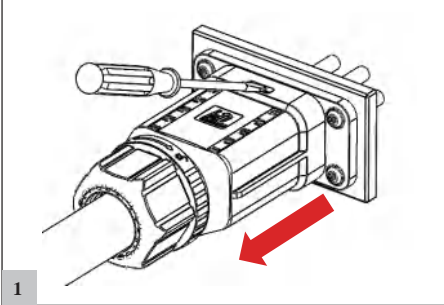
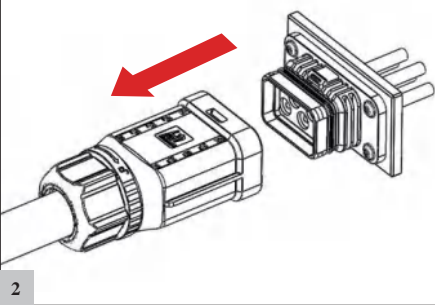
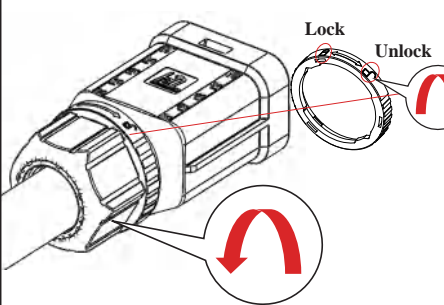
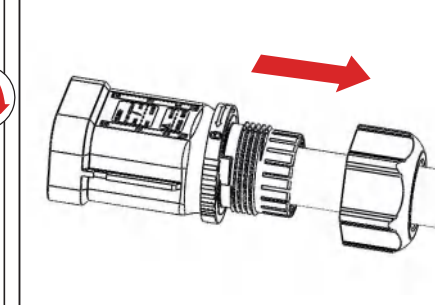
 <p>1</p>	 <p>2</p>
 <p>Lock Unlock</p> <p>Hold the unlocking button with one hand and turn the nut in the Unlock direction with the other hand.</p> <p>3</p>	 <p>4</p> <p>Remove the nut.</p>

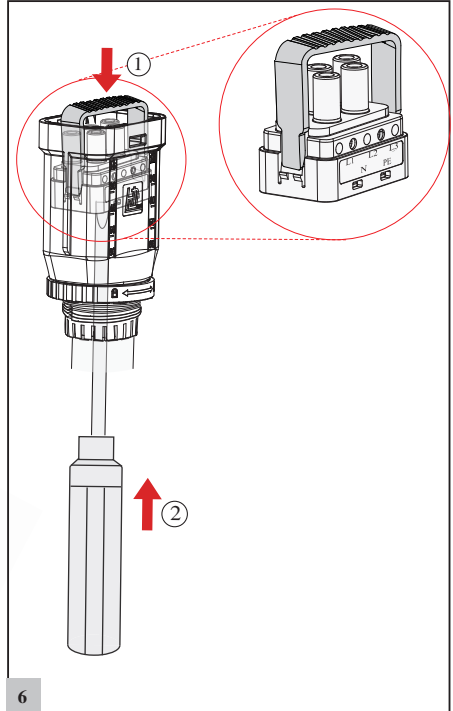
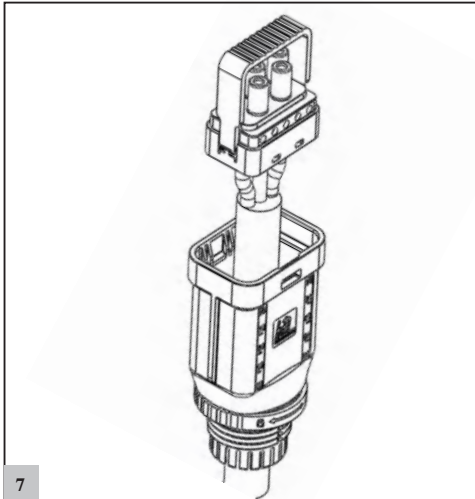
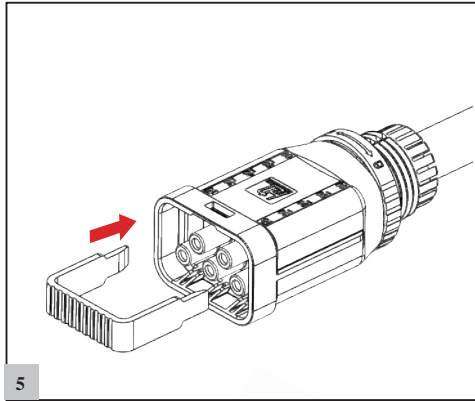

Step 2. Remove the inverter from the mounting bracket.

Step 3. Remove the mounting bracket.

9. Technical Specification

Model	5K	6K	8K	10K
Input (PV)				
Max. Input Voltage	1000V			
MPPT Operating Voltage Range	160-950V			
Max. Input Power	9000W	9000W	15000W	15000W
Max. Input Current	15A/15A	15A/15A	20A/30A	20A/30A
Max. Short Circuit Current	20A/20A	20A/20A	30A/40A	30A/40A
Max. Number of PV Strings	2(1/1)		3(1/2)	
No. of MPPTs	2			
Input (Battery)				
Compatible battery type	Lithium-ion/Lead-acid			
Battery voltage range	150-600V			
Nominal battery voltage (Full load)	250-600V			
Max. charge/discharge current	25A/25A	25A/25A	50A/50A	50A/50A
Max. charge/discharge power	9000W/5800W	9000W/7000W	15000W/9100W	15000W/11300W
Lithium battery charge curve	Self-adaption to BMS			
Output (On Grid)				
Rated Grid voltage	380V/400V/415V 3W+N+PE			
Rated Grid Frequency	50Hz/60Hz			
Grid Frequency Range**	45Hz-55Hz/55Hz-65Hz			
Nom. Power (Output)	5000W	6000W	8000W	10000W
Maximum Power (Output)	5500W	6600W	8800W	11000W
Apparent Power (Output)	5500VA	6600VA	8800VA	11000VA
Maximum Current (Output)	3*8.3A	3*10A	3*13.3A	3*16.7A/3*16A ^①
Maximum Current (Input)	3*25A	3*25A	3*25A	3*25A
THDI	< 5% (according to different on-Grid regulation)			
DC Current Injection	< 0.5% In			
Power Factor	> 0.99 Rated power (Adjustable 0.8 Leading - 0.8Lagging)			
Output (Backup)				
Nom. power	5000VA	6000VA	8000VA	10000VA
Maximum power(5min)	6000VA	7200VA	9600VA	12000VA
Maximum power(10s)	7500VA	9000VA	12000VA	15000VA
Rated voltage	380V/400V/415V 3W+N+PE			
Backup switch time	10ms(typical), 20ms(max)			
THDV	< 3% (R Load) ,8% (RCD Load)			
Efficiency				
Max. Efficiency (PV to Grid)*	98.2%	98.2%	98.4%	98.4%
European Efficiency (PV to Grid)*	97.2%	97.2%	97.9%	97.9%
Max. Charge Efficiency (PV to Battery)*	98%	98%	98%	98%
Max. Charge/Discharge Efficiency (Grid to Battery)*	98%	98%	98%	98%

①: The specification of “3*16A” is only for British Market.

Protection		
DC switch	Support	
Anti-islanding protection	Support	
AC overcurrent protection	Support	
AC short circuit protection	Support	
AC over-voltage protection	Support	
SPD	DC Type2, AC Type2	
GFCI	Support	
AFCI	Optional	
RSD	Optional (Tigo/APS)	
Insulation detection	Support	
General		
Topology	Transformerless	
IP Rating	IP65	
Cooling	Natural cooling	
Operating Temperature Range	-25°C-60°C	
Relative Humidity Range	0-100%	
Max. Operating Altitude	4000m(>2000m derating)	
Noise	<30dB(Measured at 1m)	
Dimensions (W*H*D)	530*550*213mm	
Weight	29.6KG	32KG
HMI & COM		
Display	APP +LED	
Communication	WiFi/GPRS/4G/Ethernet(optional);	
	BMS(CAN/RS485)	
	DRM	
	1*DI	
	2*DO	
	METER(RS485)	
	RS485	
Certification		
Safety	IEC 62109-1/2 ,IEC 62040,IEC 62477	
EMC	IEC/EN 61000-6-3, IEC 61000-3-11, IEC 61000-3-12, IEC/EN 61000-6-2	
Grid Code	IEC 61727, IEC 62116, EN 50549-1, VDE 4105, AS 4777,CEI 0-21.G98	
Warranty	5 Years/10 Years (Optional)	

Remarks :

- *Not yet test ;
- **The range of output voltage and frequency may vary depending upon different grid codes.
- Specifications are subject to change without advance notice.