

Version: EN-UM-1.1



# USER MANUAL

---

## Single-phase ESS Inverter

## HISTORY

VERSION	ISSUED	COMMENTS
1.0	17-Mar.-23	First release
1.1	26-Jul.-23	Update the DO descriptions in 9-Pin of 4.6 Communication Connection section.
1.2	28-Aug.-23	Update the contents of the CT.

## Preface

### About This Manual

This manual describes the installation, connection, the use of APP, commissioning and maintenance etc. of ESS inverter. Please first read the manual and related documents carefully before using the product and store it in a place where installation, operation and maintenance personnel can access it at any time. The illustration in this user manual is for reference only. This user manual is subject to change without prior notice. (Specific please in kind prevail.)

### Target Group

ESS inverters must be installed by professional electrical engineers who have obtained relevant qualifications.





### Scope

This manual is applicable to the following inverters:

- BE3.6KW-1PH
- BE3.68KW-1PH
- BE4.6KW-1PH
- BE5KW-1PH
- BE6KW-1PH

### Conventions

The following safety instructions and general information are used within this user manual.

 <b>DANGER</b>	Indicates an imminently hazardous situation which, if not correctly followed, will result in serious injury or death.
 <b>WARNING</b>	Indicates a potentially hazardous situation which, if not correctly followed, will result in serious injury or death.
 <b>CAUTION</b>	Indicates a potentially hazardous situation which, if not correctly followed, could result in moderate or minor injury.
 <b>NOTICE</b>	Indicates a potentially hazardous situation which, if not correctly followed, could result in equipment failure to run, or property damage.
 <b>NOTE</b>	Call attention to important information, best practices and tips: supplement additional safety instructions for your better use of the ESS inverter to reduce the waste of you resource.

# CONTENTS

## **Preface**

- About This Manual
- Target Group
- Scope
- Conventions

## **1. Safety**

- 1.1 Symbols Used
- 1.2 Safety Precaution

## **2. Product Introduction**

- 2.1 Overview
- 2.2 Product Appearance
- 2.3 Model Definition

## **3. Installation**

- 3.1 Packing List
- 3.2 Selecting the Mounting Location
- 3.3 Mounting

## **4. Electrical Connection**

- 4.1 Grounding
- 4.2 GRID/BACKUP Connection
- 4.3 Battery Connection
- 4.4 PV Connection
- 4.5 Meter/CT Connection
- 4.6 Communication Connection

## **5. System Operation**

- 5.1 Inverter Working Mode
- 5.2 Startup/Shutdown Procedure

## **6. Commissioning**

- 6.1 Inspection
- 6.2 Commissioning Procedure

## **7. User Interface**

- 7.1 LED
- 7.2 App Setting Guide

## **8. Maintenance**

- 8.1 Routine Maintenance
- 8.2 Inverter Troubleshooting
- 8.3 Removing the Inverter









## **9. Technical Specifications**

# 1. Safety

Before using the inverter, please read all instructions and cautionary markings on the unit and in this manual. Put this manual to a place where you can take it easily.

Our ESS inverter strictly conforms to related safety rules in design and test. Please follow the local laws and regulations during installation, operation and maintenance. Incorrect operation may cause injury or death to the operator or a third party, and damage to the inverter and other properties belonging to the operator or a third party.

## 1.1 Symbols Used

Safety Symbol	Description
	Danger of high voltage! Only qualified personnel may perform work on the inverter.
	Residual voltage exists after the inverter is powered off. It takes 5 minutes for system to discharge to a safe voltage.
	Danger of hot surface
 Do not disconnect under load!	Do not disconnect under load, otherwise there will be a danger of fire.
	Environmental Protection Use Period
	Refer to the operating instructions
	Don't dispose of the inverter with the household waste.
	Grounding terminal

## 1.2 Safety Precaution

- Installation, maintenance and connection of inverters must be performed by qualified personnel, in compliance with local electrical standards, wiring rules and requirements of local power authorities and/or companies.
- The temperature of some parts of the inverter may exceed 60°C during operation. Do not touch the inverter during operation to avoid being burnt.
- Ensure children are kept away from inverters.
- Don't open the front cover of the inverter. Apart from performing work at the wiring terminal (as instructed in this manual), touching or changing components without authorization may cause injury to people, damage to inverters and annulment of the warranty.
- Static electricity may damage electronic components. Appropriate methods must be adopted to prevent such damage to the inverter; otherwise the inverter may be damaged and the warranty annulled.
- Ensure the output voltage of the proposed PV array is lower than the maximum rated input voltage of the inverter; otherwise the inverter may be damaged and the warranty annulled.
- When exposed to sunlight, the PV array generates dangerous high DC voltage. Please operate according to our instructions, or it will result in danger to life.
- PV modules should have an IEC61730 class A rating.
- If the equipment is used in a manner not specified by the manufacturer, the protection provided by the equipment may be impaired.
- Completely isolate the inverter before maintaining. Completely isolate the inverter should: turn off the PV switch and disconnect the PV terminal, battery terminal, and AC terminal.
- After the inverter is powered off, the remaining electricity and heat may still cause electric shock and body burns. Do not touch parts of inverter for 10 minutes after disconnection from the power sources.
- Prohibit inserting or pulling the AC and DC terminals when the inverter is running.
- In Australia, the inverter internal switching does not maintain the neutral neutral continuity. And neutral integrity must be addressed by external connection arrangements.
- Don't connect ESS inverter in the following ways:
  - The BACKUP Port should not be connected to the grid;
  - A single PV panel string should not be connected to two or more inverters.

## 2. Product Introduction

### 2.1 Overview

#### Hybrid Inverter

The hybrid inverters are high-quality inverter which can convert solar energy to AC energy and store energy into battery. Typically, an ESS inverter system consists of PV array, ESS inverter, battery, loads and electricity sensor.

The energy generated by inverter can be preferentially supplied to its self-consumption, stored in the battery for future use or fed into public grid.

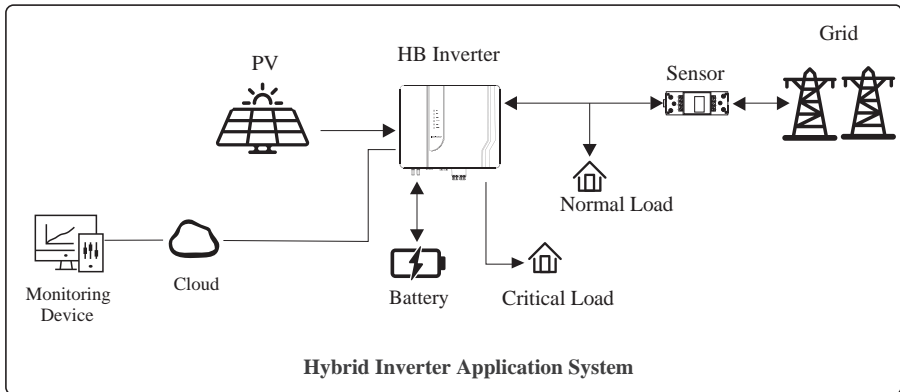

#### AC Couple Inverter

The AC couple inverters are high-quality inverter which can store energy into battery.

The inverter can be used to optimize self consumption, store in the battery for future use or feed into public grid. Work mode depends on the battery and user's preference. It can provide power for emergency use during the grid lost by using the energy from battery.

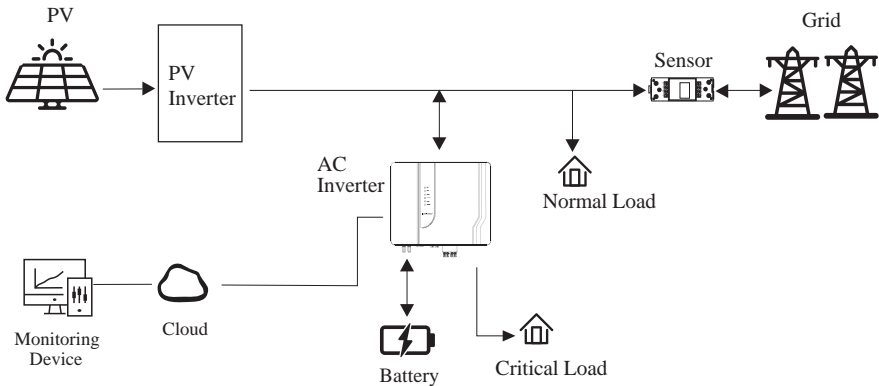

**AC Couple Inverter Application System**

## 2.2 Product Appearance

### 2.2.1 Hybrid Inverter

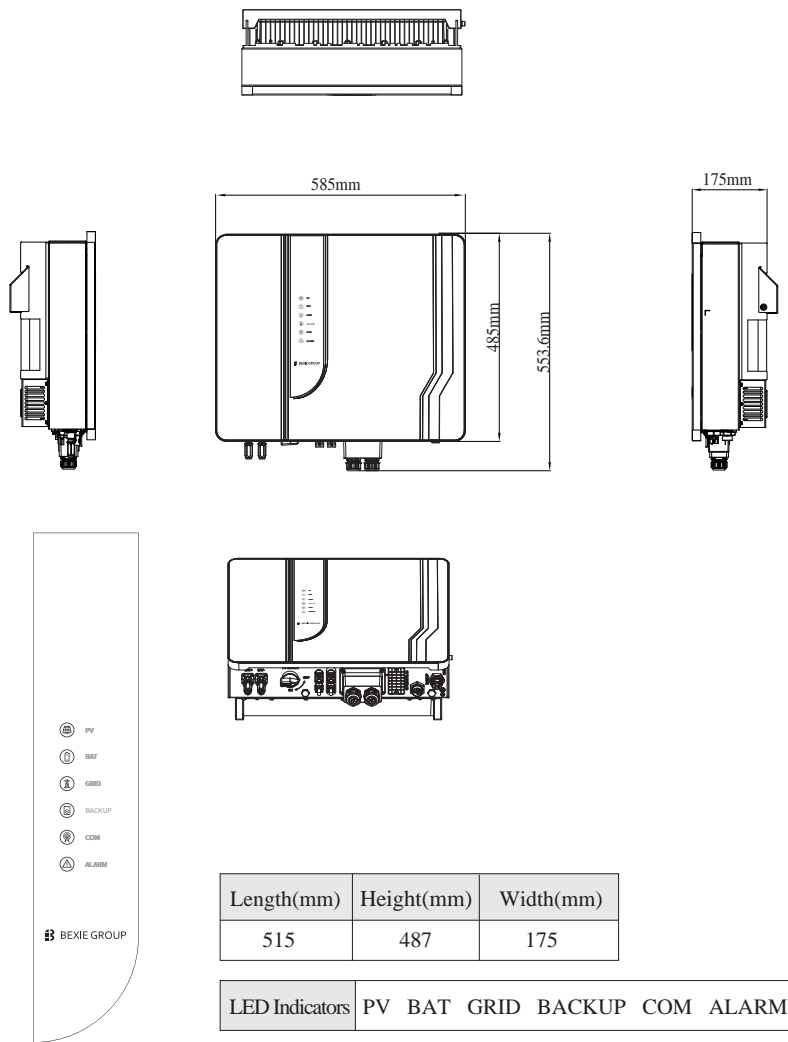

**LED Details**

**The External View of Hybrid Inverter**

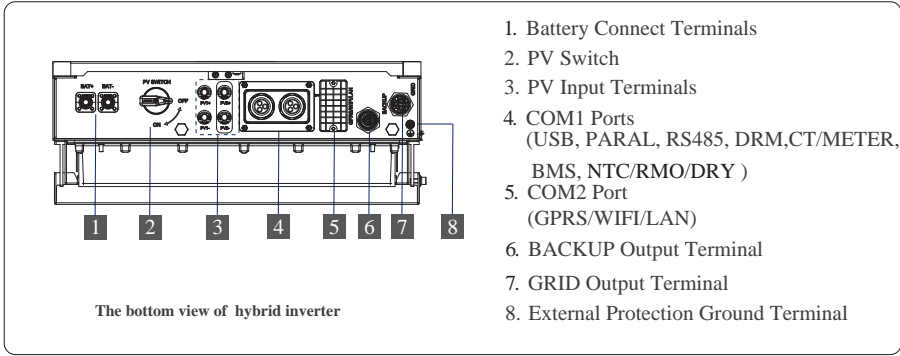

### 2.2.2 AC Couple Inverter

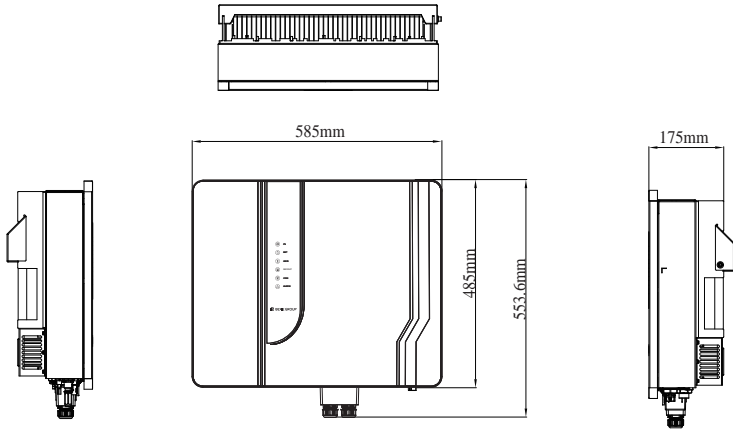

LED Details

Length(mm)	Height(mm)	Width(mm)
515	487	175

LED Indicators	BAT	GRID	BACKUP	COM	ALARM
----------------	-----	------	--------	-----	-------

The External View of AC Couple Inverter

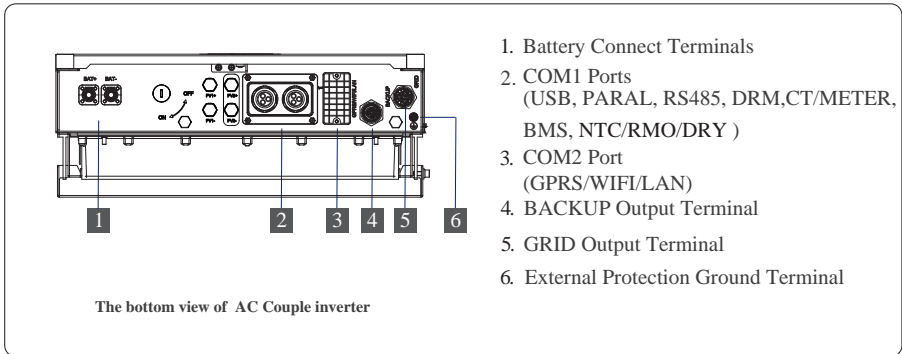

Note: The appearances of hybrid inverter and AC couple inverter are presented in detail in this section. The following chapters are only illustrated by hybrid inverter.

### 2.3 Model Definition

The letters in the product model have the specific informations.  
 (Take BE5KW-1PH as examples.)

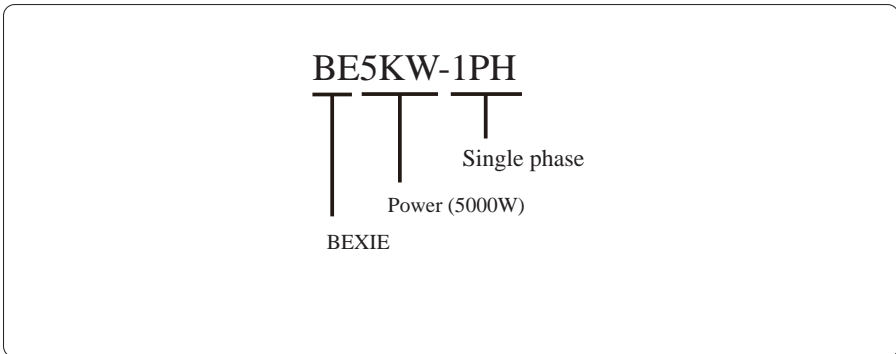

### 3. Installation

#### 3.1 Packing List

After unpacking, please check the following packing list carefully for any damage or missing parts. If any damage or missing parts occurs, contact the supplier for help.

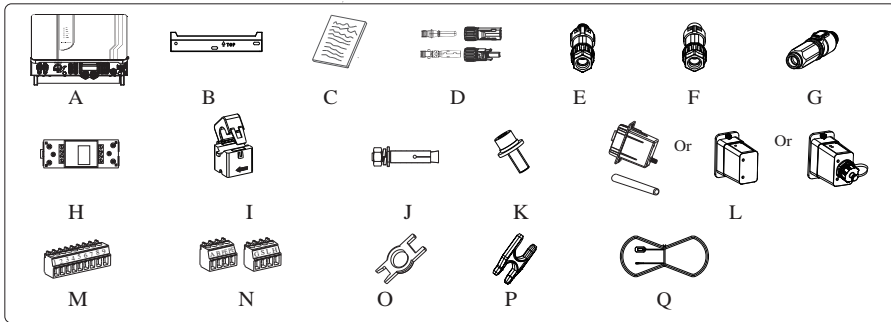

Number	Quantity	Description
A	1	Inverter
B	1	Mounting bracket
C	1	File package
D	2/2	PV terminal connector group (PV+/PV-); N/A for AC Couple
E	1	BACKUP connector
F	1	GRID connector
G	2	Battery connector
H	1	Meter (Optional)
I	1	CT
J	3	M12 Expansion screws
K	1	M6 Security screw
L	1	GPRS/WIFI/LAN module (Optional)
M	1	9-Pin terminal
N	2	4-Pin terminal
O	1	Removal tool for PV connector
P	1	Removal tool for GRID/BACKUP connector
Q	1	Battery Temperature sensor (Optional)

### 3.2 Selecting the Mounting Location

#### 3.2.1 Installation Environment Requirements

- a. With an IP65 protection rating, the inverter can be mounted indoors or outdoors.
- b. The mounting location must be inaccessible to unrelated personnel since the enclosure and heat sinks are extremely hot during operation.
- c. Do not install the inverter in areas containing highly flammable materials or gases.
- d. To ensure optimum operation and long service life, the ambient temperature must be below 50°C.
- e. The inverter must be mounted in a well-ventilated environment to ensure good heat dissipation.
- f. To ensure long service life, the inverter must not be exposed to direct solar irradiation, rain, or snow. It is recommended that the inverter be mounted in a sheltered place.
- g. The carrier where the inverter is mounted must be fire-proof. Do not mount the inverter on flammable building materials.
- h. Do not install the inverter in a rest area since it will cause noise during operation.
- i. The installation height should be reasonable, and please make sure it is easy to operate and view the display.
- j. Product label and warning symbols shall be clear to read after installation.
- k. Please avoid direct sunlight, rain exposure, snow cover.

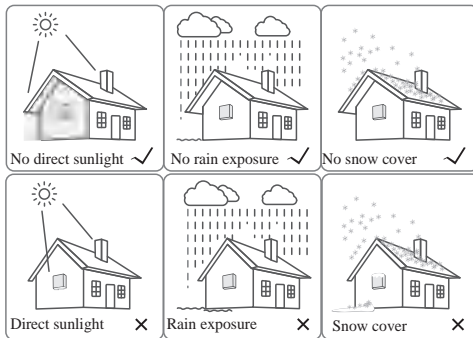

### 3.2.2 Mounting Requirements

Mount the inverter vertically or tilted backward by max 15°. The device can not be installed with a wrong mode and the connection area must point downward.

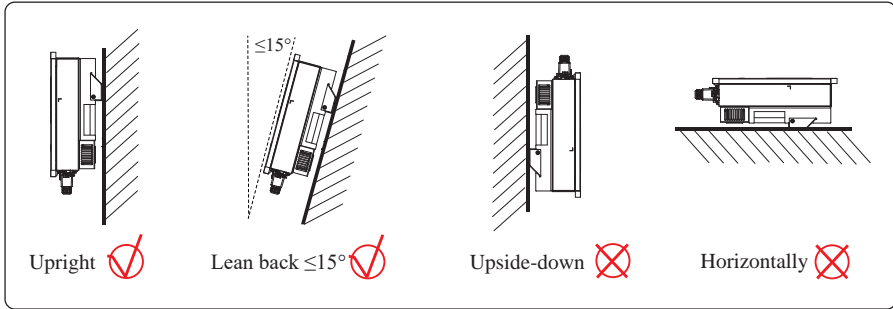

### 3.2.3 Installation Space Requirements

To ensure the inverter normally and easy to operate, there are requirements on available spaces of the inverter, e.g. to keep enough clearance. Refer to the following figures.

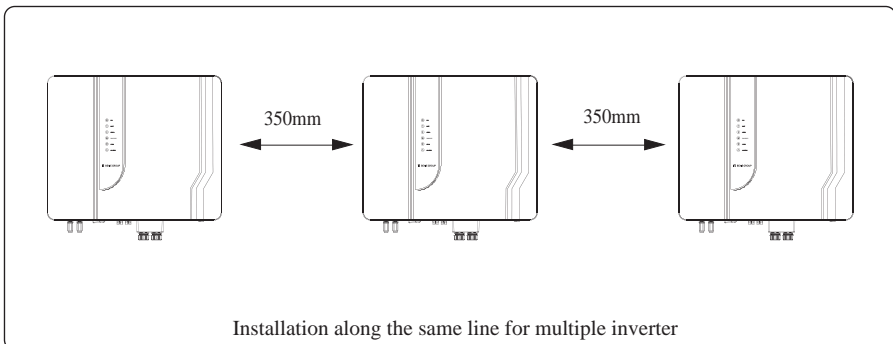
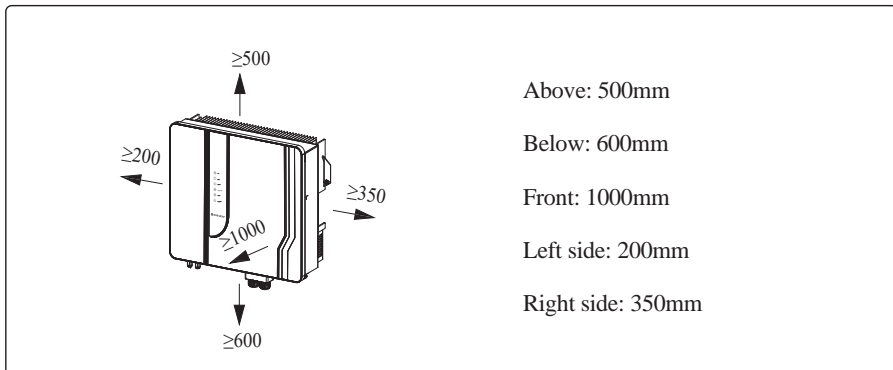

### 3.3 Mounting

Before mounting the inverter, you have to prepare expansion screws and a security screw.

#### Step 1. Install the mounting bracket

1. Use a level ruler to mark the position of the 3 holes on the wall. Refer to Figure a. And drill 3 holes, 16mm in diameter and 55mm in deep. Refer to Figure b.
2. Knock the expansion screw kit into the hole together with a hammer. Refer to Figure c.  
*Note: Do not remove the nut unit in this step.*
3. After tightening 2-3 buckles, the expansion bolts are tight and not loose, and then unscrew the bolts, spring washer, gasket. Refer to Figure c.
4. Install and fix the mounting bracket on the wall. Refer to Figure d.

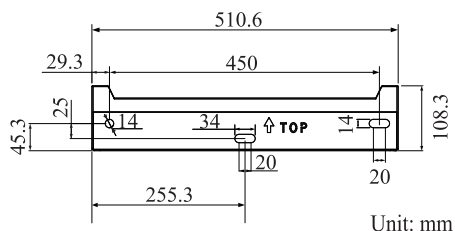

#### Step 2. Install the inverter on the mounting bracket. Then lock the inverter using the security screw. Refer to Figure e, Figure f.

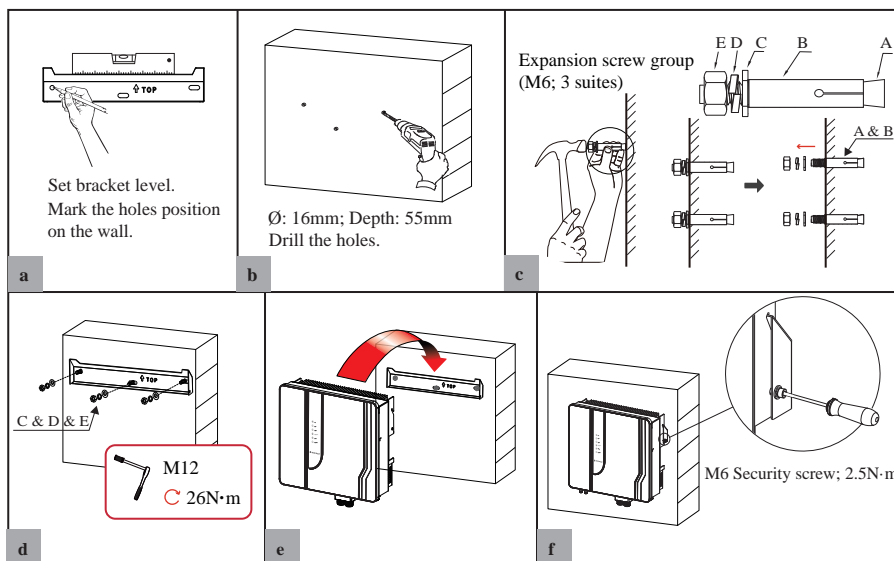

<p><b>DANGER</b></p>	<p>Before frilling the hole on the wall, ensure no damage on the electric wire and/or water pipe inside the wall.</p>
----------------------	---

<p><b>CAUTION</b></p>	<p>To prevent potential damages and injuries from inverter falling down, please hang the inverter on the bracket, do not loosen grip unless confirm the inverter is well mounted.</p>
-----------------------	---

## 4. Electrical Connection

This chapter shows the details connection of ESS inverter. And PV connection is N/A for AC couple inverters. The following illustration only uses the hybrid inverters as an example.

### ESS inverter system connection diagram:

#### Non-parallel connection mode

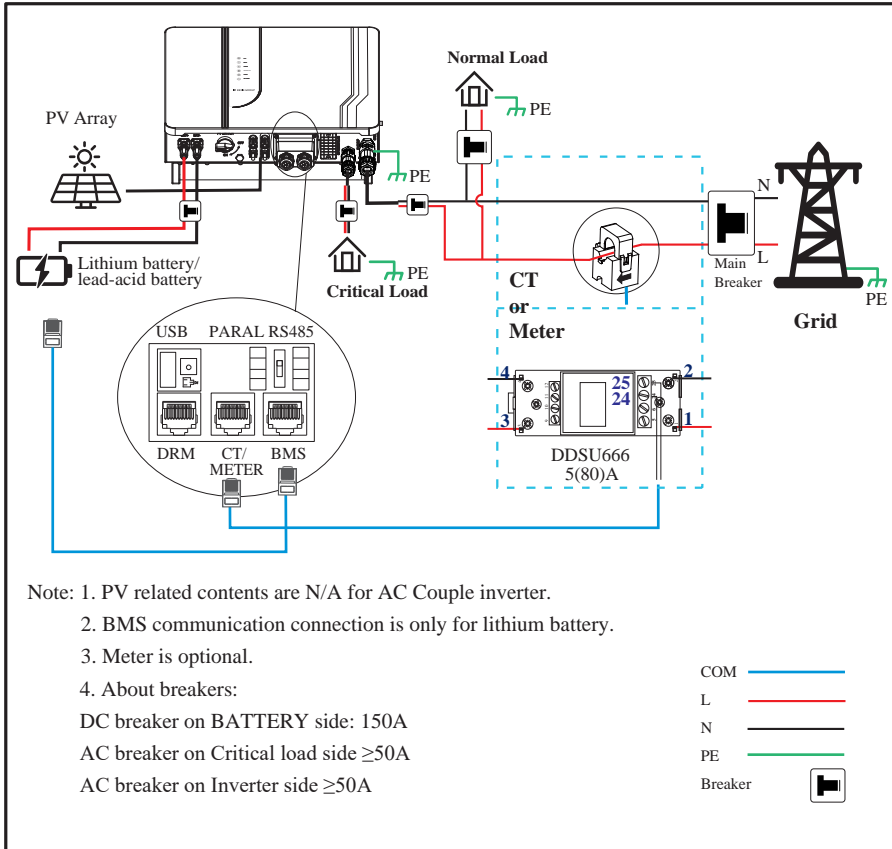

<p><b>DANGER</b></p>	<p>Ensure that the inverter and all cables to be installed have been completely powered off during the whole process of installation and connection. Otherwise, fatal injury could be caused by the high voltage.</p>
----------------------	---

**Single phase parallel connection mode-Scheme A (N≤5)**

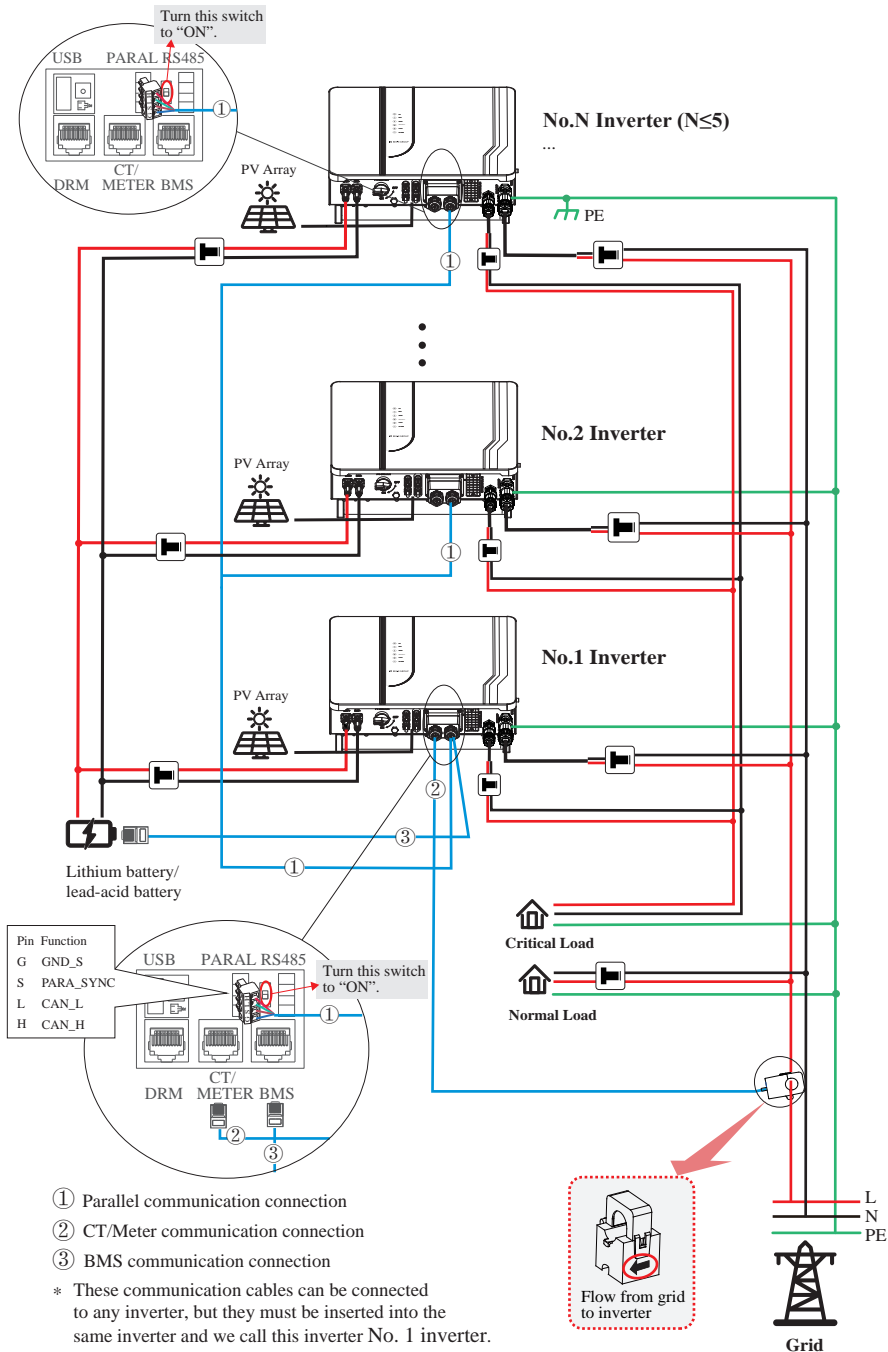

**Note for Scheme A:**

1. PV related contents are N/A for AC Couple inverter.
2. BMS communication connection is only for lithium battery.
3. It is necessary to turn the matched resistance switch of No. 1 inverter and No. N inverter to “ON” in parallel connection mode.
4. With parallel connection mode, it is necessary to connect APP to one of inverters and then go to [Console > Other Setting](#) page to enable [Parallel mode](#) on APP. Please refer to section 7.2.3.
5. About breakers:  
DC breaker on BATTERY side: 150A  
AC breaker on Critical load side  $\geq 50A$   
AC breaker on Inverter side  $\geq 50A$

**DANGER**

Ensure that the inverter and all cables to be installed have been completely powered off during the whole process of installation and connection. Otherwise, fatal injury could be caused by the high voltage.

**Single phase parallel connection mode-Scheme B (N>5)**

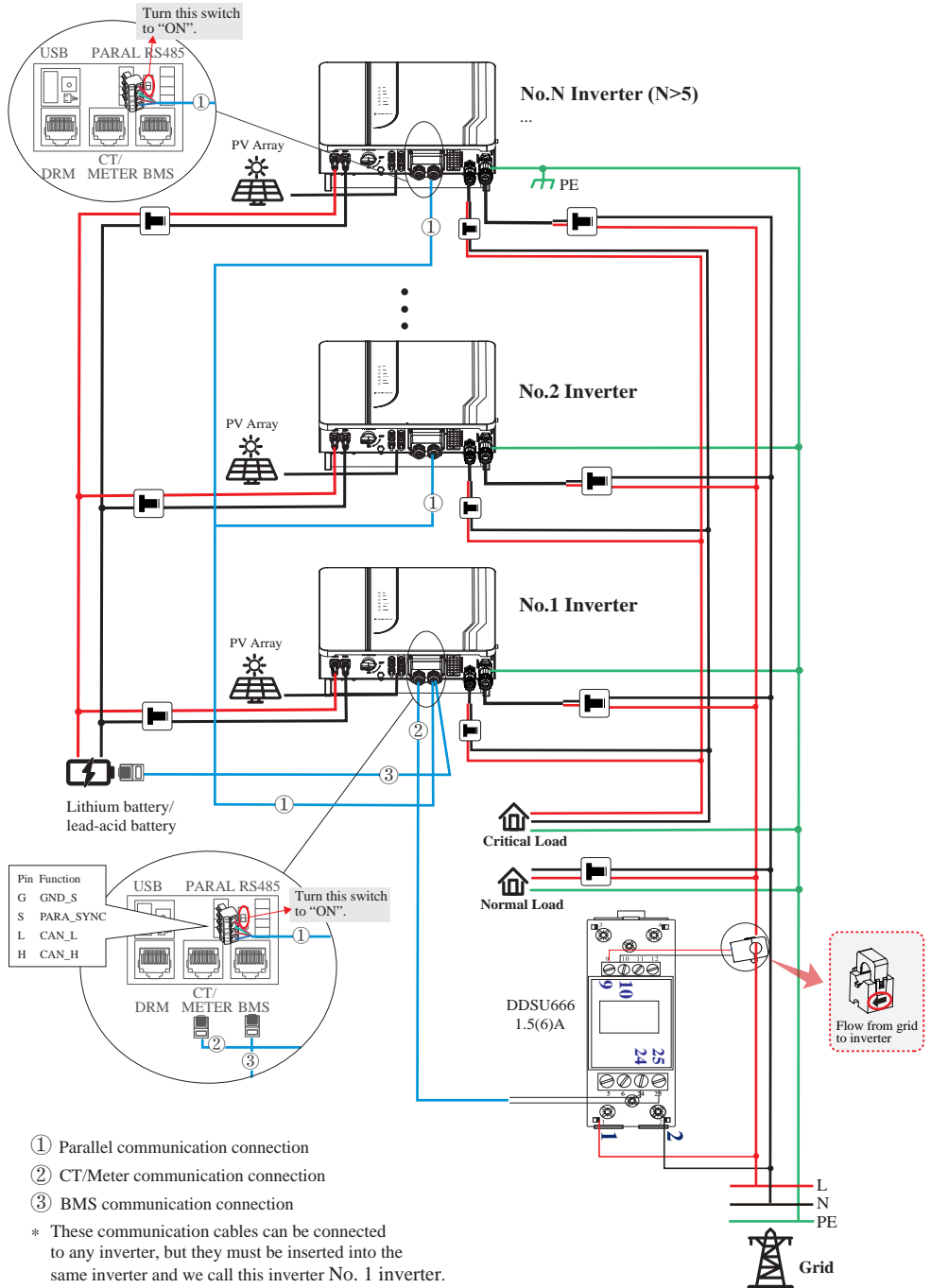

**Note for Scheme B:**

1. PV related contents are N/A for AC Couple inverter.
2. BMS communication connection is only for lithium battery.
3. It is necessary to additionally purchase suitable CT and meter according to the specific requirements in parallel connection mode-Scheme B.
4. It is necessary to turn the matched resistance switch of No. 1 inverter and No. N inverter to “ON” in parallel connection mode.
5. With parallel connection mode, it is necessary to connect APP to one of inverters and then go to [Console > Other Setting](#) page to enable [Parallel mode](#) on APP. Please refer to section 7.2.3.
6. About breakers:  
DC breaker on BATTERY side: 150A  
AC breaker on Critical load side  $\geq 50A$   
AC breaker on Inverter side  $\geq 50A$

**DANGER**

Ensure that the inverter and all cables to be installed have been completely powered off during the whole process of installation and connection. Otherwise, fatal injury could be caused by the high voltage.

### 4.1 Grounding

A protective earth (PE) terminal is equipped at the side of the inverter. Please be sure to connect this PE terminal to the PE bar for reliable grounding. AWG 10 or 12 yellow green lines are recommended.

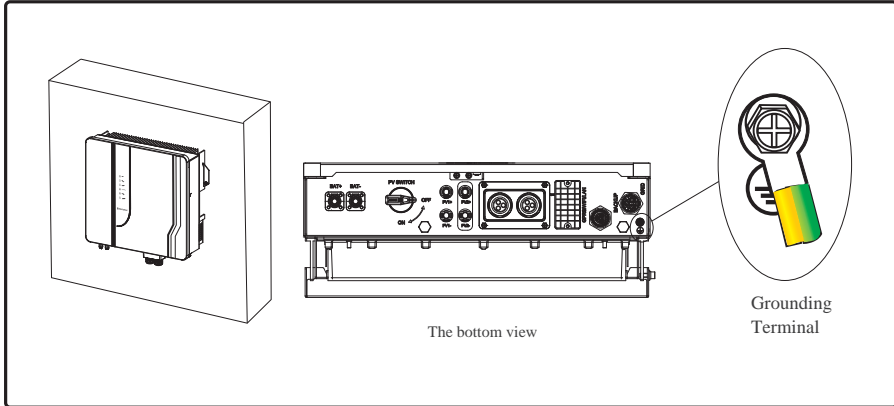

 <b>WARNING</b>	<p>The inverter must be grounded; otherwise, there may be electric shock risk.</p>
--	--

 <b>CAUTION</b>	<p>If the positive pole or negative pole of the PV array is required to be grounded, then the inverter output (to AC grid) must be isolated by transformer in accordance with IEC62109-1, -2 standards.</p>
--	---

## 4.2 GRID/BACKUP Connection

Before connecting the GRID/BACKUP terminal, ensure that both the AC terminal and the DC terminal are powered OFF and the PV switch is OFF. Otherwise there is a risk of high voltage shock.

GRID/BACKUP connection please refer to below.

Step 1: Assemble the AC connector and then insert AC connector into GRID/BACKUP port.

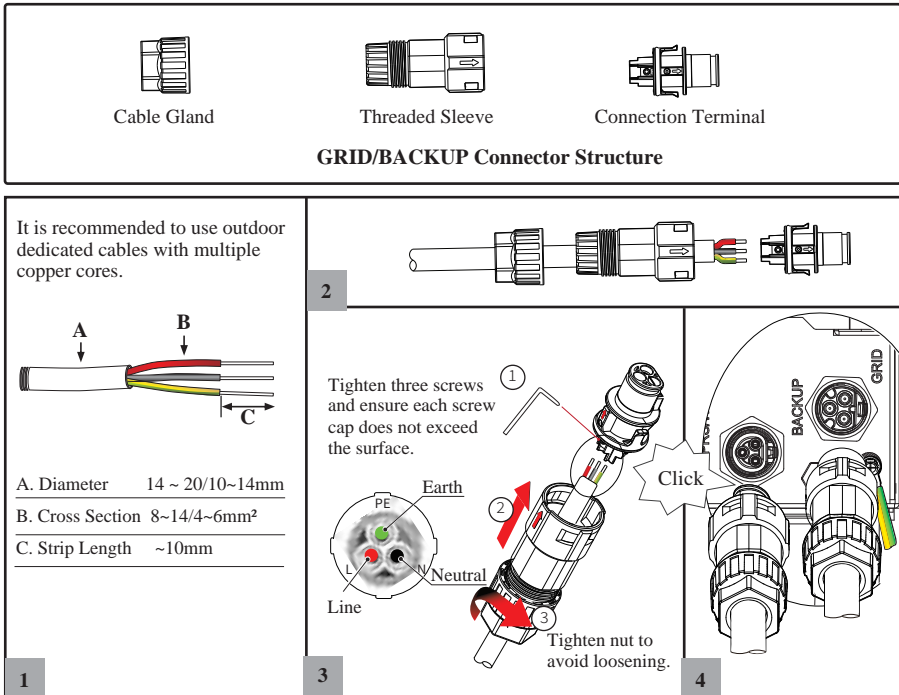

Step 2: Connect the AC breaker.

An AC breaker should be installed between inverter and the GRID/BACKUP.

- a. Before connecting the AC cable from inverter to AC breaker, you should confirm the AC breaker is working normally. Turn off the AC breaker and keep the status.
- b. Connect the PE conductor to grounding electrode, and connect the N and L conductors to AC breaker.
- c. Connect the AC breakers to the GRID/BACKUP.

 <p><b>NOTICE</b></p>	<ul style="list-style-type: none"> <li>Multiple inverters are not allowed to share a circuit breaker.</li> <li>Load is not allowed to connect between the inverter and the AC breaker.</li> </ul>
--	---

To ensure that the inverter can be safely and reliably disconnected from the grid, an AC breaker (≥50A) should be installed only for inverter GRID/BACKUP port..

### 4.3 Battery Connection

ESS inverter now only supports the lithium/lead-acid battery. The recommended lithium battery brands are as follows: PYLON LPF, Aoboet LPF, Dyness LPF, UZENERGY L051100-A.

This part only describes the battery connection on inverter side. If you need more detailed connection information about the battery side, please refer to the manual of the battery you used.

Before connecting to battery, please install a separate DC breaker (150A; not equipped) between inverter and battery. This will ensure the inverter can be securely disconnected during maintenance.

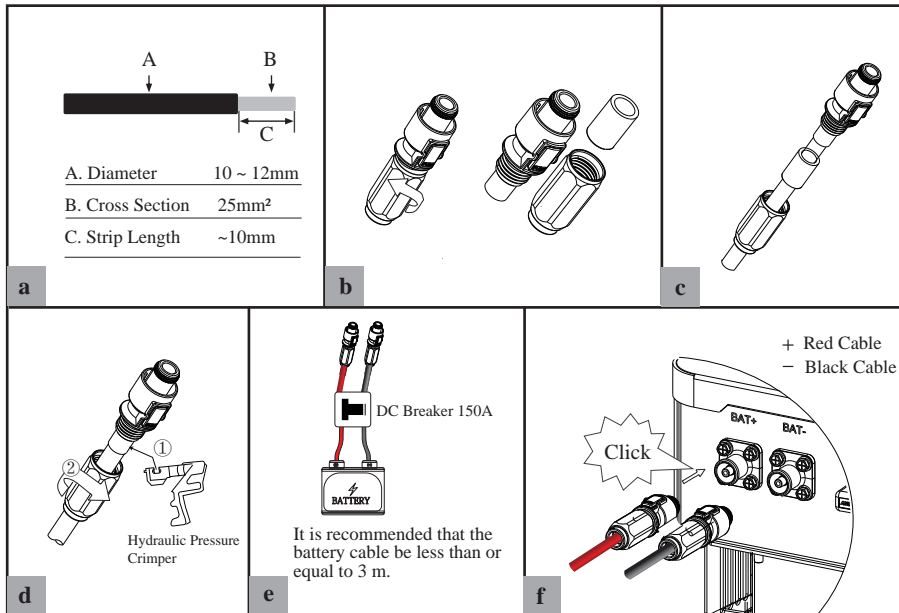

 <p><b>WARNING</b></p>	<ul style="list-style-type: none"> <li>• Polarity reverse will damage the inverter!</li> <li>• Be careful of electric shock and chemical hazards!</li> <li>• To reduce risk of injury, please use the suitable recommended cable size.</li> </ul>
---	---

### Battery Communication Connection

If the battery type is lithium battery which need communication between the inverter and battery management system (BMS), the connection must be installed.

Please refer to section 4.6.1 for details.

### NTC connection for lead-acid battery

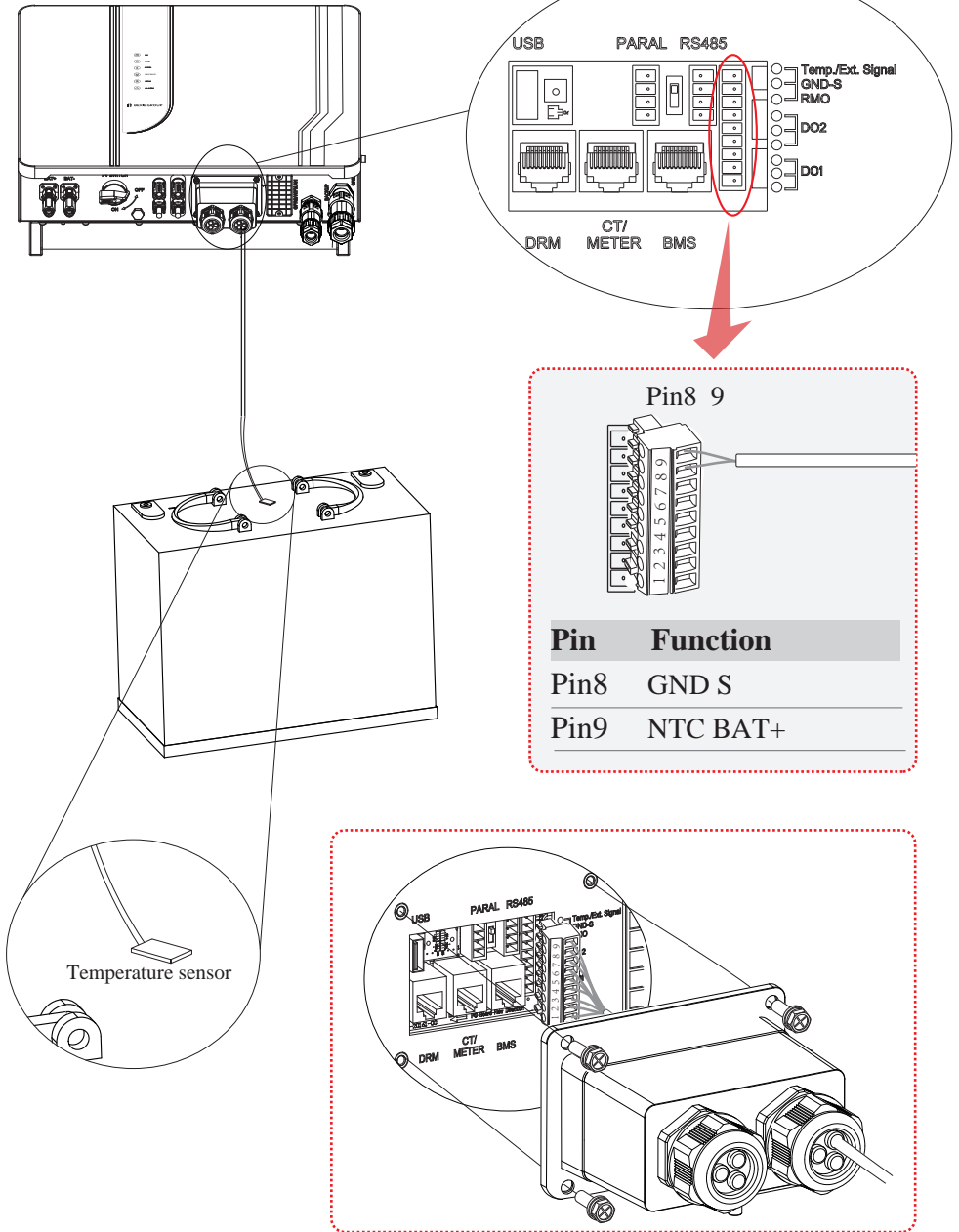

### 4.4 PV Connection (N/A for AC Couple Inverter)

PV connection please refer to below.

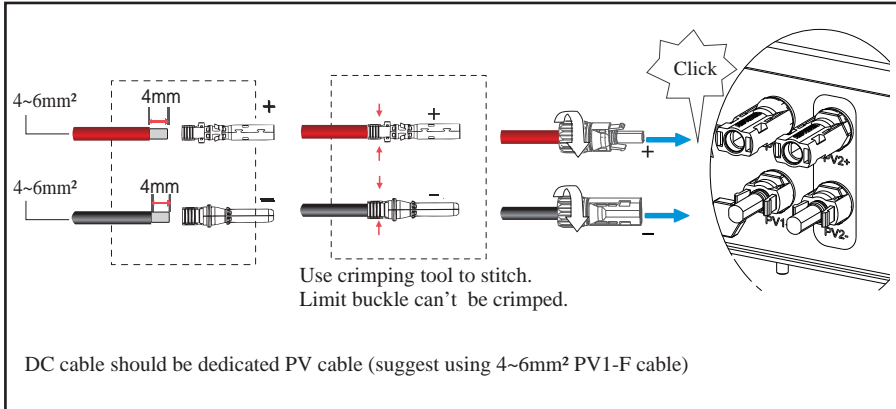

**NOTICE**

- Before connection the PV panels, make sure the plug connector have the correct polarity. Incorrect polarity could permanently damage the inverter.
- PV array shouldn't be connected to the grounding conductor.
- The minimum insulation resistance to ground of the PV panels must exceed 18.33kΩ, there is a risk of shock hazard if the requirement of minimum resistance is not met.

**WARNING**

Please check polarity of PV connectors!  
If polarity reversed, do not try to disconnect any PV connector until the irradiance declines and the DC currents fall below 0.5 A!  
Only then disconnect the PV plugs and correct the polarity before reconnecting.

## 4.5 Meter/CT Connection

You can monitor usage with a meter or a CT.

### 4.5.1 Meter Connection

This section is applicable to non-parallel connection mode only.

ESS inverter supports the meter CHINT-DDSU666 meter by default. The meter is optional.

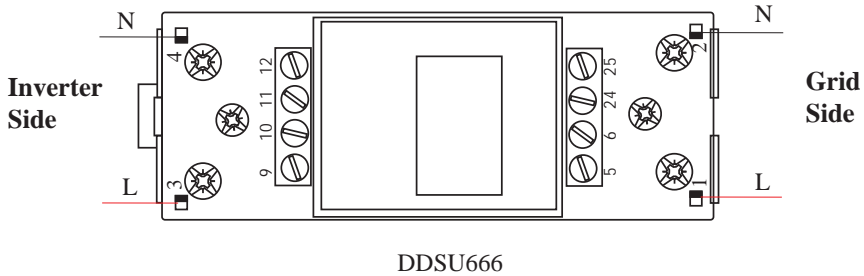

Before connecting to Grid, please install a separate AC breaker (not equipped) between meter and Grid. This ensures that the inverter can be safely disconnected during maintenance.

The connection diagram of power cable of meter is as shown in the figure below:

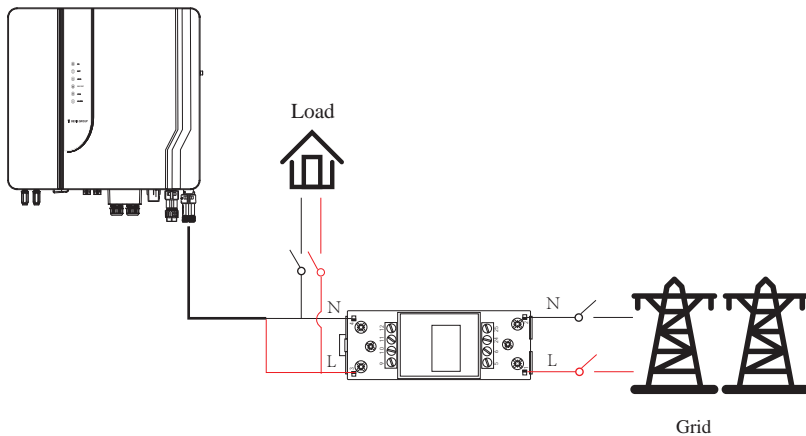

Please refer to the meter instruction manual for details.

### 4.5.2 CT Connection

Before connecting to Grid, please install a separate AC breaker (not equipped) between CT and Grid. This will ensure the inverter can be safely disconnected during maintenance.

The connection diagram of power cable of CT is as shown in the figure below:

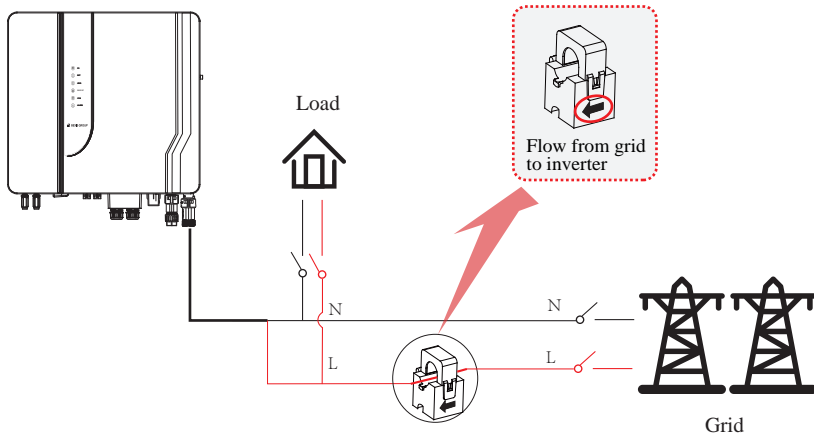

Please attention to the Current measuring transformer (CT) connection. The arrow on the CT indicates the current flow from grid to inverter. And lead the live line through the detection hole of CT.

 <b>NOTE</b>	<p>The current direction from grid to inverter is defined as positive and current direction from inverter to grid is defined as negative.</p>
--	---

### 4.6 Communication Connection

There are communication interfaces in the communication port on the bottom of the inverter as show below :

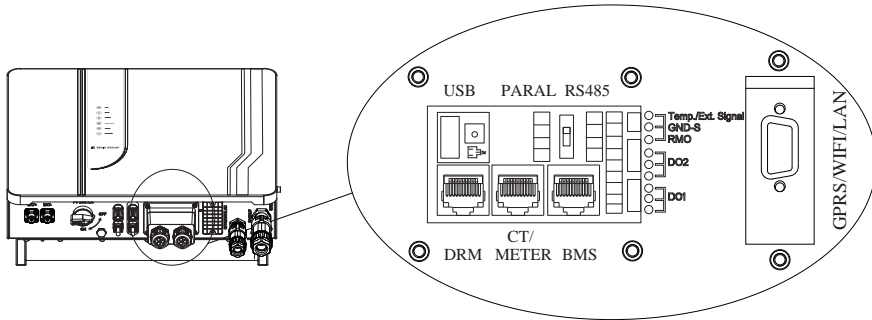

Interface		Descriptions
USB		For fast firmware upgrade.
PARAL		4-Pin interface for parallel communication
		A matched resistance switch for parallel communication
RS485		4-Pin interface for RS485 communication
DRM		Demand response mode for Australia application
CT/METER		For Meter communication or Grid current sense.
BMS		Lithium battery communication interface
9-Pin	DO1	Dry contact control (reserved)
	DO2	Dry contact control (reserved)
	RMO	Remote off control
	Temp./Ext. Signal	Temperature sensor terminal of lead-acid battery/External signal
GPRS/WIFI/LAN		For GPRS/WIFI/LAN communication.

### 4.6.1 BMS Connection (Only for Lithium Battery)

#### RJ45 Terminal Configuration of Battery Communication (BMS)

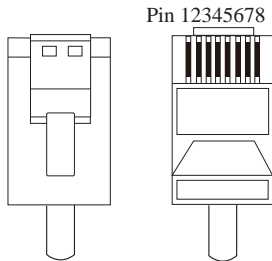

<b>PIN</b>	1	2	3	4
<b>Function Description</b>	RS485_A	RS485_B	GND_S	CAN_H
<b>PIN</b>	5	6	7	8
<b>Function Description</b>	CAN_L	GND_S	CAN_L	CAN_H

This manual describes the cable sequence of the inverter. For details about the cable sequence of the battery, see the manual of the battery you used.

Refer to the following steps:

**a** Unscrew the waterproof cover and loosen the rubber nut on waterproof cover.

**c**

- ① Insert RJ45 terminal into corresponding port.
- ② Screw the waterproof cover back to inverter firmly with 4 x M4 screws(1.2N·m).
- ③ Install the seal into the threaded sleeve, fasten the rubber nut.

**b** Make the RJ45 terminal according to above function description of each Pin definition. Lead the BMS cable through the rubber nut, seal and waterproof cover in turn.

Don't cut off any communication cables.

Press the BMS cable in the seal via the side incisions.

### 4.6.2 DRMs Connection

DRMs is a shortened form for “inverter demand response modes”. It is a compulsory requirements for inverters in Australia.

Note: With DRMs connection, it is necessary to connect APP to inverter and then go to [Console > Other Setting](#) page to enable [DRM function](#) on APP. Please refer to section 7.2.3.

#### RJ45 Terminal Configuration of DRMs

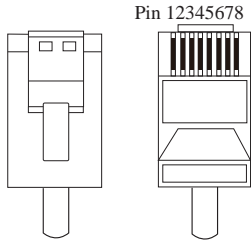

<b>PIN</b>	1	2	3	4
<b>Function Description</b>	DRM1/5	DRM2/6	DRM3/7	DRM4/8
<b>PIN</b>	5	6	7	8
<b>Function Description</b>	REF	DRM 0/COM	NC	NC

Refer to the following steps:

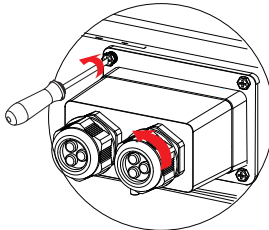

**a** Unscrew the waterproof cover and loosen the rubber nut on waterproof cover.

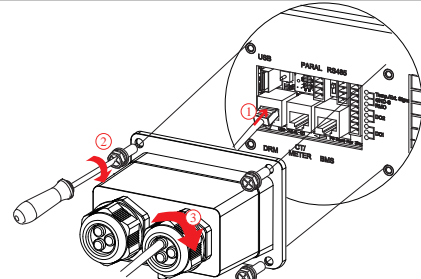

**c**

- ① Insert RJ45 terminal into corresponding port.
- ② Screw the waterproof cover back to inverter firmly with 4 x M4 screws(1.2N·m).
- ③ Install the seal into the threaded sleeve, fasten the rubber nut.

**b** Make the RJ45 terminal according to above function description of each Pin definition. Lead the BMS cable through the rubber nut, seal and waterproof cover in turn.

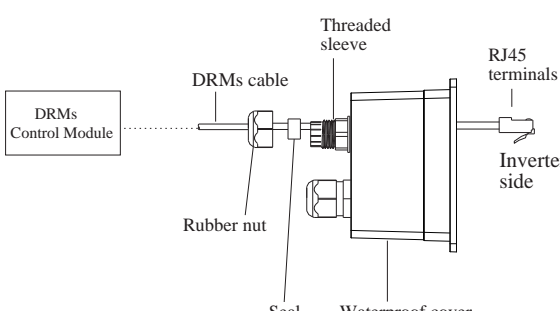

DRMs Control Module

DRMs cable

Rubber nut

Seal

Waterproof cover

Threaded sleeve

RJ45 terminals

Inverter side



Don't cut off any communication cables.

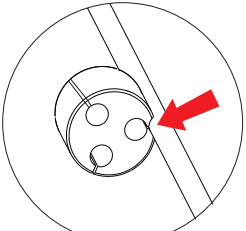

Press the DRMs cable in the seal via the side incisions.

### 4.6.3 Meter/CT Connection

#### RJ45 Terminal Configuration of Meter/CT Communication

Pin 12345678

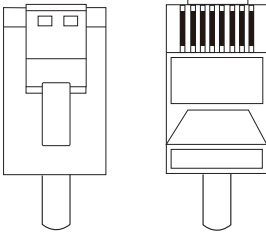

PIN	1	2	3	4	5	6	7	8
<b>Function Description</b>	RS485_A	RS485_B	RS485_A/ Test +	RS485_B	CT-	CT+	Test-	NC

#### 4.6.3.1 Meter Connection

##### Meter cable connection overview

RJ45	Meter
Pin1 or Pin3(RS485_A )	Pin24
Pin2 or Pin4(RS485_B )	Pin25

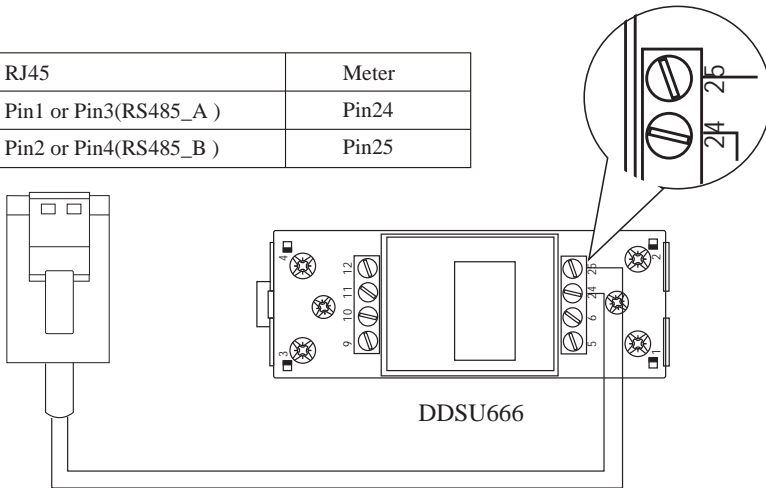

**Connect meter. Refer to the following steps:**

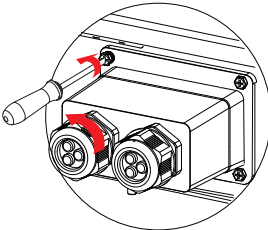

**a** Unscrew the waterproof cover and loosen the rubber nut on waterproof cover.

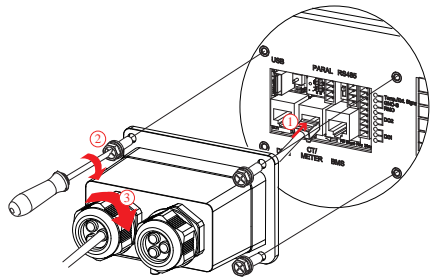

**c**

- ① Insert RJ45 terminal into corresponding port.
- ② Screw the waterproof cover back to inverter firmly with 4 x M4 screws(1.2N·m).
- ③ Install the seal into the threaded sleeve, fasten the rubber nut.

**b** Make the RJ45 terminal according to above function description of each Pin definition.  
Lead the meter communication cable through the rubber nut, seal and waterproof cover in turn.

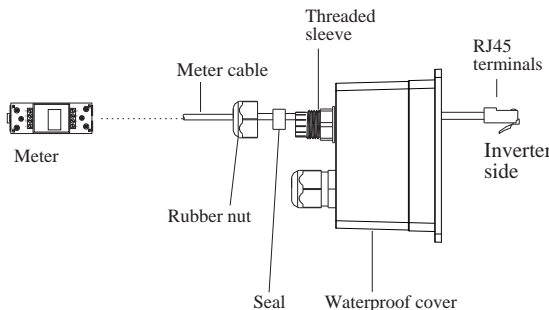



Don't cut off any communication cables.

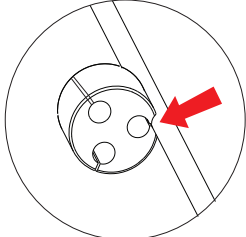

Press the meter cable in the seal via the side incisions.

**4.6.3.2 CT Connection**

This section is applicable to non-parallel connection mode and parallel connection-scheme A only.

**CT cable connection overview**

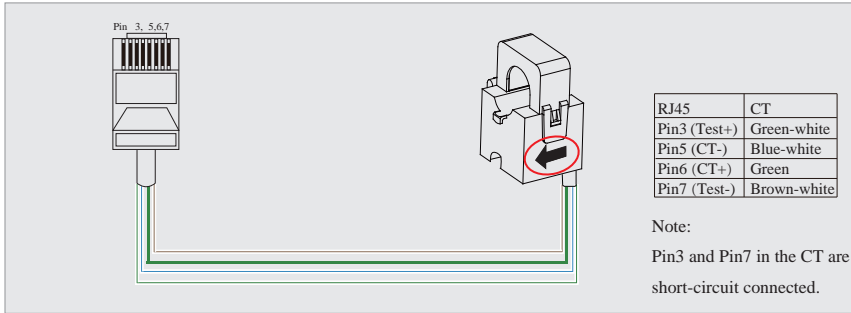

RJ45	CT
Pin3 (Test+)	Green-white
Pin5 (CT-)	Blue-white
Pin6 (CT+)	Green
Pin7 (Test-)	Brown-white

Note:  
Pin3 and Pin7 in the CT are short-circuit connected.

**Connect CT. Refer to the following steps:**

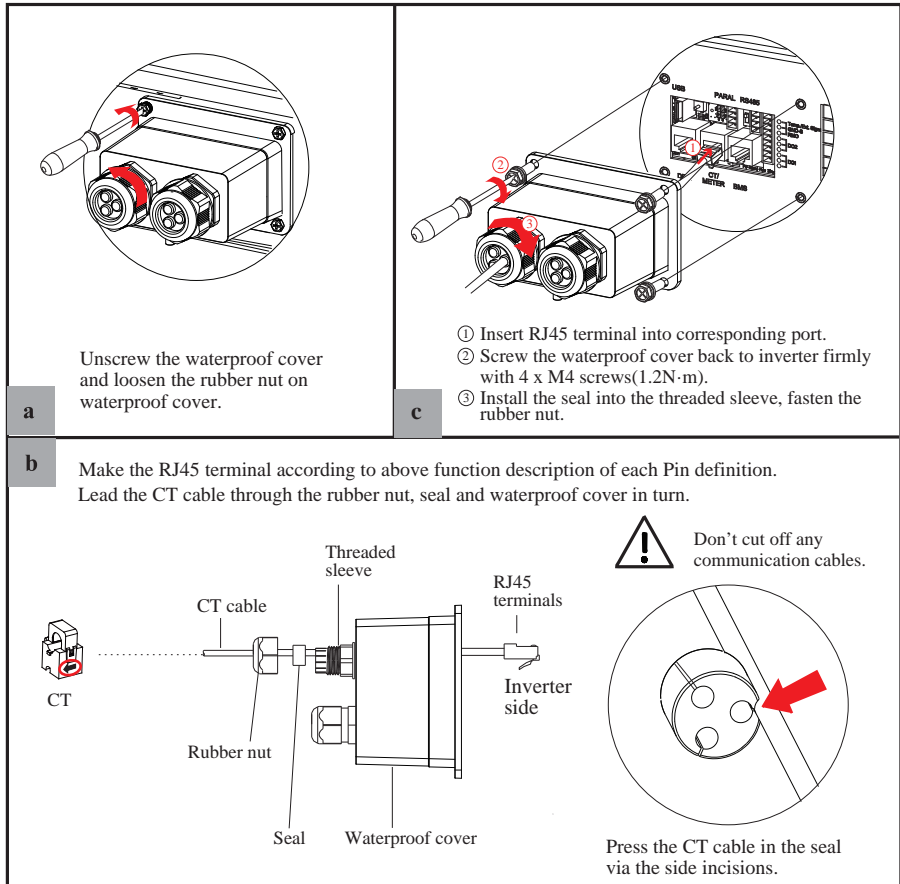

**a**

Unscrew the waterproof cover and loosen the rubber nut on waterproof cover.

**c**

- ① Insert RJ45 terminal into corresponding port.
- ② Screw the waterproof cover back to inverter firmly with 4 x M4 screws(1.2N·m).
- ③ Install the seal into the threaded sleeve, fasten the rubber nut.

**b**

Make the RJ45 terminal according to above function description of each Pin definition. Lead the CT cable through the rubber nut, seal and waterproof cover in turn.

 Don't cut off any communication cables.

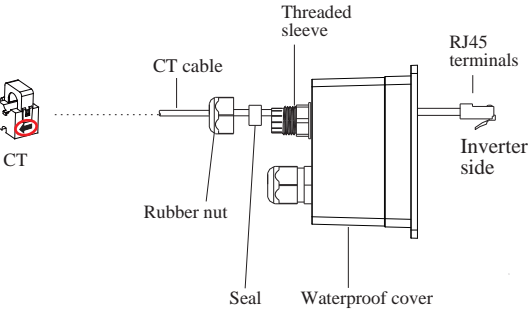

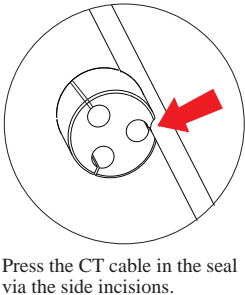
 Press the CT cable in the seal via the side incisions.

### 4.6.4 RS485 Connection

#### 4-Pin Terminal Configuration of RS485 Communication



PIN	A	B	PE	PE
Function Description	RS485_A	RS485_B	PE	PE

Connect RS485. Refer to the following steps:

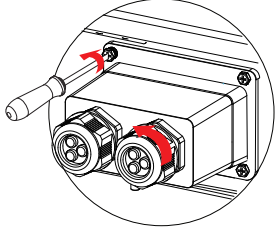

**a** Unscrew the waterproof cover and loosen the rubber nut on waterproof cover.

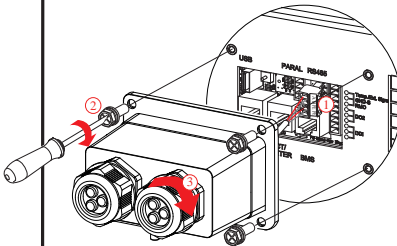
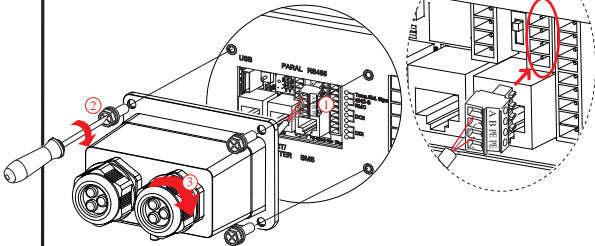



**c**

- ① Insert 4-Pin terminal into corresponding port.
- ② Screw the waterproof cover back to inverter firmly with 4 x M4 screws(1.2N·m).
- ③ Install the seal into the threaded sleeve, fasten the rubber nut.

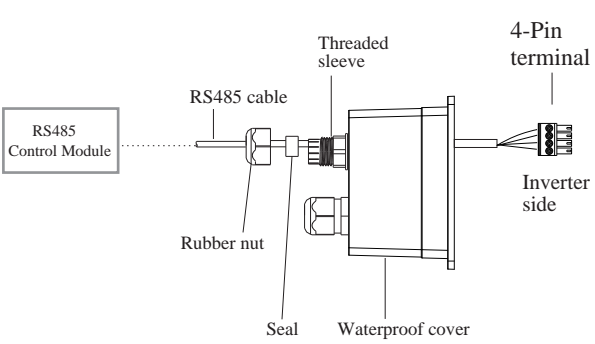
**b** Make the 4-Pin terminal according to above function description of each Pin definition.  
Lead the RS485 cable through the rubber nut, seal and waterproof cover in turn.





Don't cut off any communication cables.

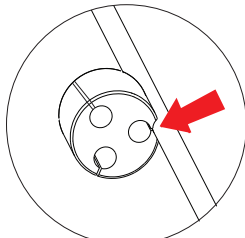

Press the RS485 cable in the seal via the side incisions.

### 4.6.5 Parallel Communication Connection

#### 4-Pin Terminal Configuration of parallel Communication



PIN	G	S	L	H
Function Description	GND_S	PARA_SYNC	CAN_L	CAN_H

#### Parallel communication cable connection overview

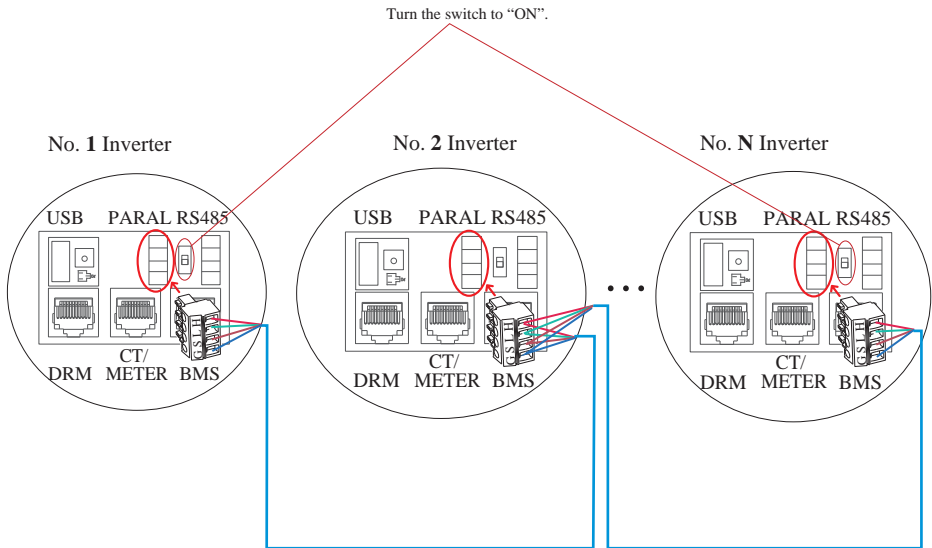

It is necessary to turn the matched resistance switch of No. 1 inverter and No. N inverter to "ON" in parallel connection mode.

No. 1 Inverter	No. 2 Inverter	.....	No. N Inverter
PinH(CAN_H)	PinH(CAN_H)		PinH(CAN_H)
PinL(CAN_L)	PinL(CAN_L)		PinL(CAN_L)
PinS(PARA_SYNC)	PinS(PARA_SYNC)		PinS(PARA_SYNC)
PinG(GND_S)	PinG(GND_S)		PinG(GND_S)

Refer to the following steps:

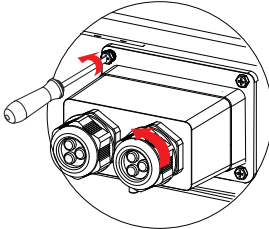

Unscrew the waterproof cover and loosen the rubber nut on waterproof cover.

**a**

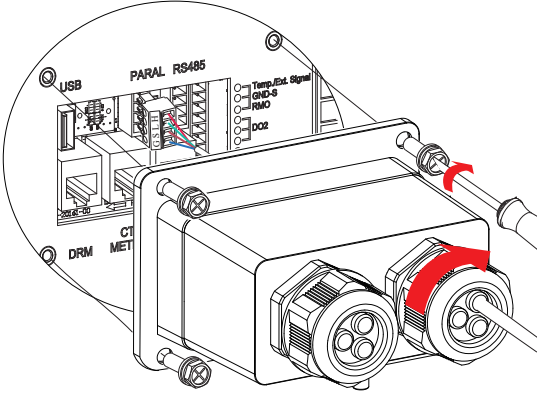

- ① Insert 4-Pin terminal into corresponding port.
- ② Screw the waterproof cover back to inverter firmly with 4 x M4 screws(1.2N·m).
- ③ Install the seal into the threaded sleeve, fasten the rubber nut.

**c**

**b** Make the 4-Pin terminal according to above function description of each Pin definition. Lead the RS485 cable through the rubber nut, seal and waterproof cover in turn.

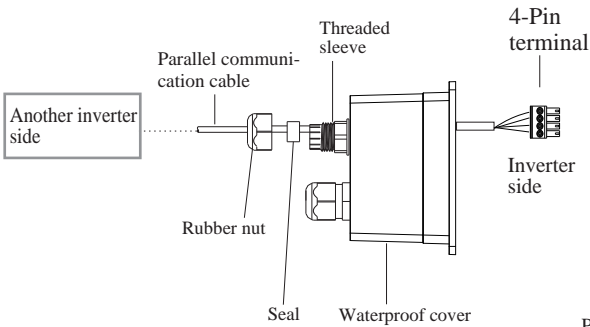



Don't cut off any communication cables.

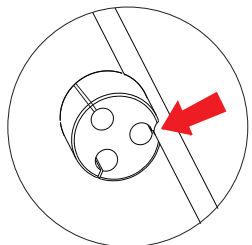

Press the Parallel communication cable in the seal via the side incisions.

**4.6.6 Temp. Ext. Signal/RMO/DRY Connection(s)**

**9-Pin Terminal Configuration of Auxiliary Communication**

Pin123456789

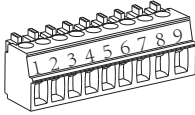

PIN	Function Description
1	NO1 (Normal Open)
2	N1 (Common Pole)
3	NC1 (Normal Close)
4	NO2 (Normal Open)
5	N2 (Common Pole)
6	NC2 (Normal Close)
7	Remote OFF
8	GND_S
9	Temp. : NTC BAT+ (NOT Italy regulation)
	Ext. Signal : External signal (Italy regulation)

Refer to the following steps:

Unscrew the waterproof cover and loosen the rubber nut on waterproof cover.

**a**

Make the 9-Pin terminal according to above function description of each Pin definition for the auxiliary port you want to use.

Lead the Temp. Ext. Signal/RMO/DRY cable(s) through the rubber nut, seal and waterproof cover in turn.

**b**

Don't cut off any communication cables.

Press the Temp. Ext. Signal/RMO/DRY cable(s) in the seal via the side incisions.

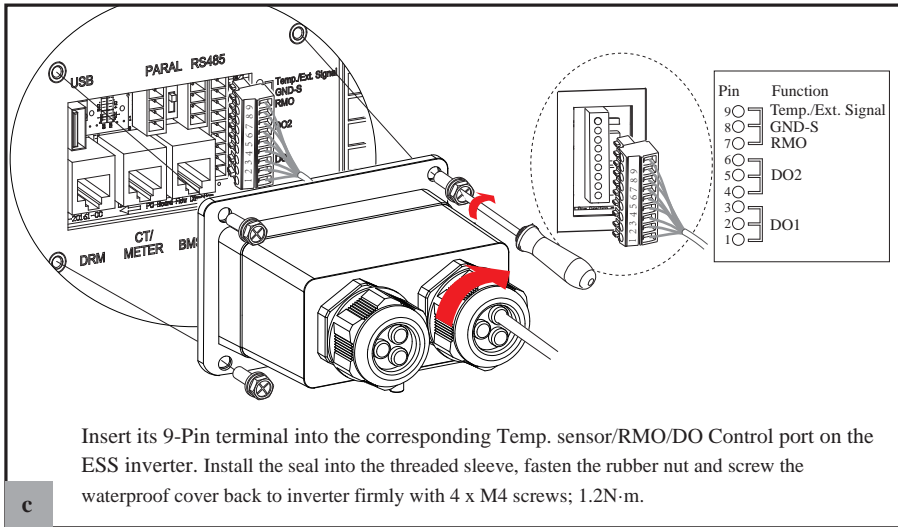

#### 4.6.7 GPRS/WIFI/LAN Module Connection (Optional)

For details, please refer to the corresponding Module Installation Guide in the packing.

The appearance of modules may be slightly different. The figure shown here is only for illustration.

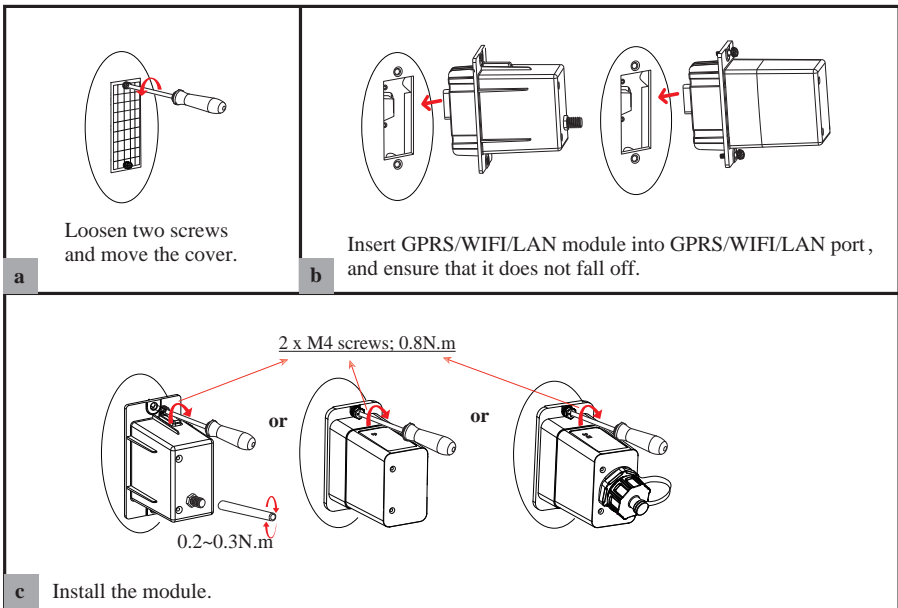

## 5. System Operation

### 5.1 Inverter Working Mode

The inverter supports several different working modes.

#### 5.1.1 Self Used Mode

Go to the "Hybrid work mode" menu, and select the "Self used mode".

Under Self Used mode, the priority of PV energy consumption will be Load > Battery > Grid, that means the energy produced by PV gives priority to powering local loads, the excess energy is used to charge the battery and the remaining energy is fed into the grid.

This is the default mode to increase self-consumption rate. There are several situations of self-used working mode based on PV energy.

##### a) Wealthy PV Energy

When PV energy is wealthy, the PV energy will be first consumed by loads, the excess energy will be used to charge the battery and then the remaining energy will be fed into the grid.

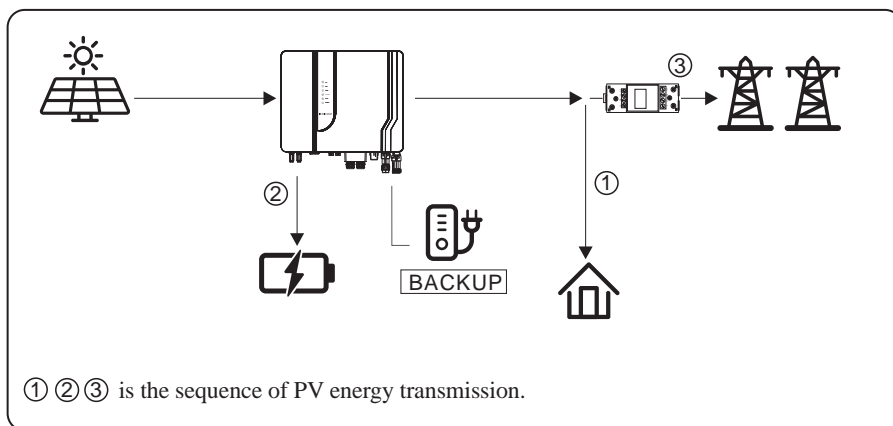

##### b) Limited PV Energy

When the PV energy is not enough to cover all consumption, the PV energy will be entirely used by loads, and the insufficient part will be supplied by battery. Then still insufficient parts will be supplied by grid.

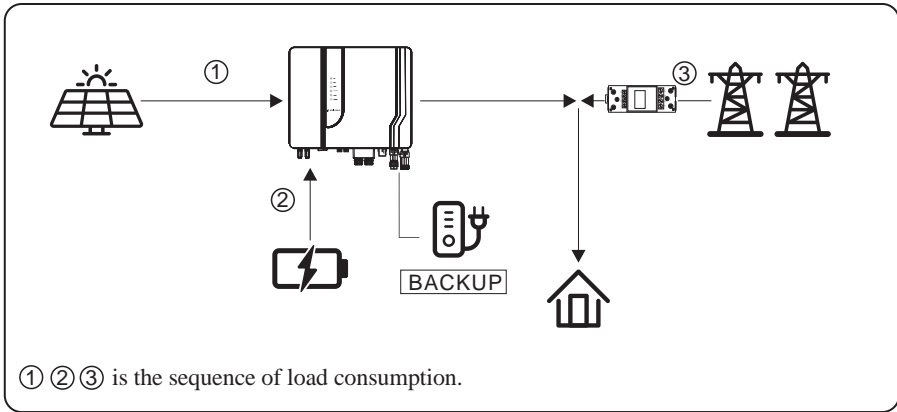

**c) No PV Input**

The inverter will first discharge the battery energy for home load consuming when no PV input( such as in the evening or some cloudy or rainy days). If the demand is not met, the loads will consume grid energy.

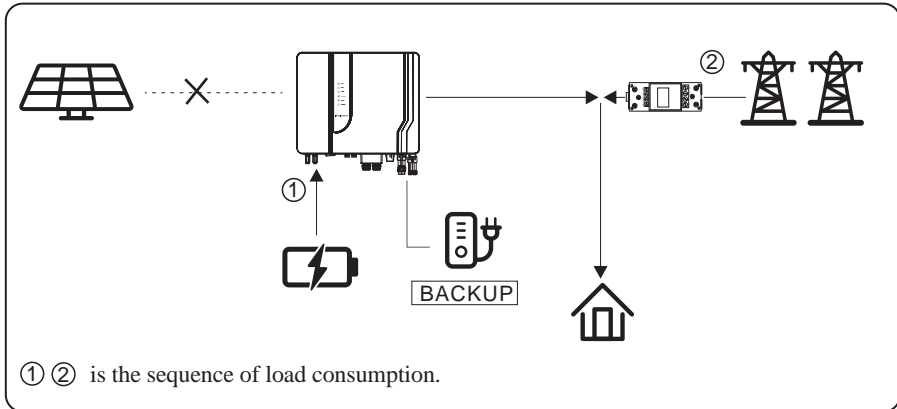

**5.1.2 Feed-in Priority Mode**

Go to the "Hybrid work mode" menu, and select the "Feed-in priority mode".

Under this mode, the priority of PV energy consumption will be Load > Grid > Battery, that means the energy produced by PV gives priority to powering local loads, the excess energy is fed into the grid, and the remaining energy is used to charge the battery.

**a) Wealthy PV Energy**

When PV energy is wealthy, the PV energy will be first consumed by loads. If there is excess PV power, the power will be fed into grid. If there is still PV energy left after load consuming and grid feeding, then the remaining PV power will be used to charge the battery.

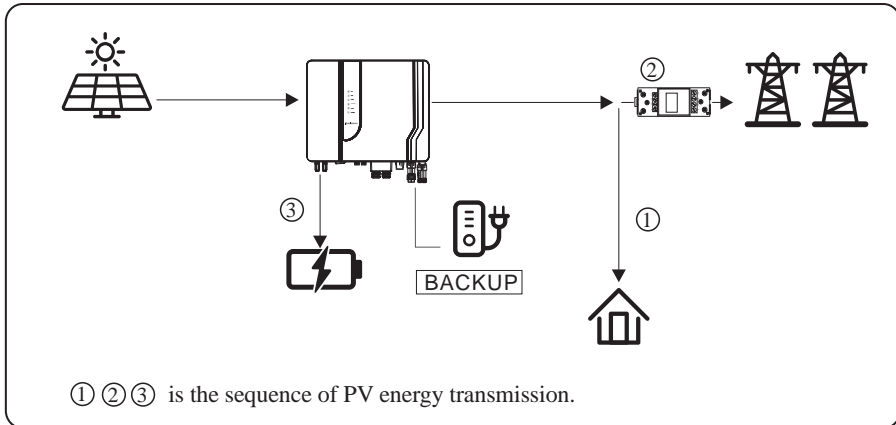

**b) Limited PV Energy**

When PV energy is limited and can not meet the feed-in grid power, the battery will discharge to meet it.

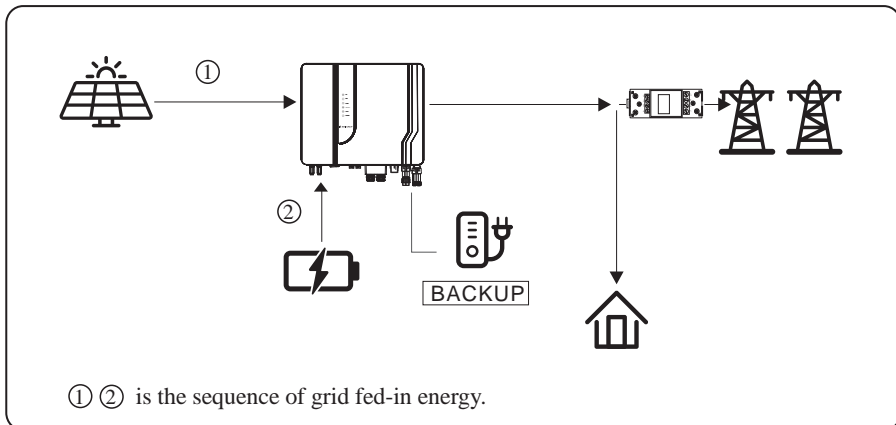

**c) No PV Input**

The inverter will first discharge the battery energy for home load consuming when no PV input (such as in the evening or some cloudy or rainy days). If the demand is not met, the loads will consume the grid energy.

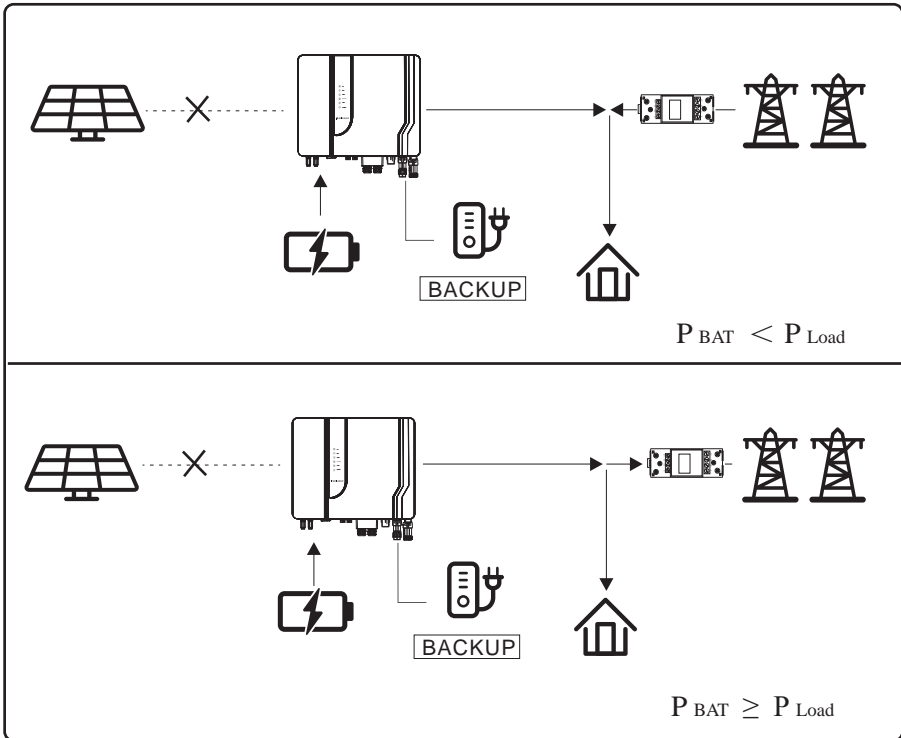

### 5.1.3 Back-up Mode

Go to the "Hybrid work mode" menu, and select the "Back-up Mode".

Under this mode, the priority of PV energy consumption will be Battery > Load > Grid.

This mode aims at charging the battery quickly, and at the same time, you can choose whether to allow AC to charge the battery.

#### Forbid AC charging

In this mode, the battery can be charged only with PV power, and the charging power varies with PV power.

#### a) Wealthy PV power

When PV energy is wealthy, PV charges the battery first, then meets the load, and the rest is fed into the grid.

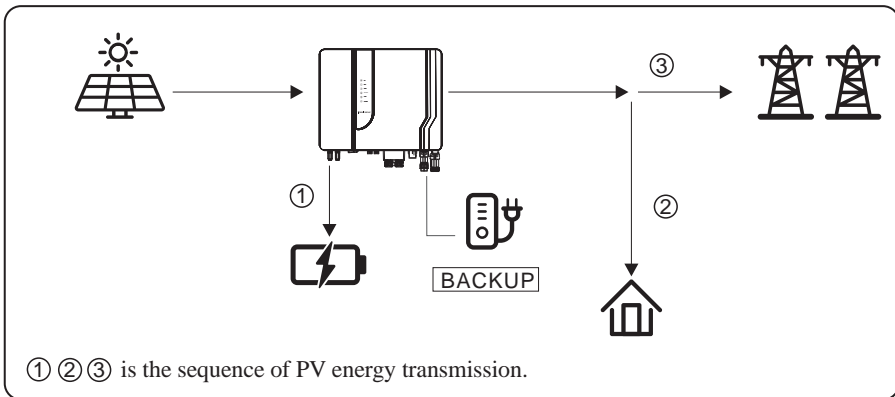

#### b) Limited PV power

When PV energy is limited, PV gives priority to charging the battery, and the grid directly meets the load demand.

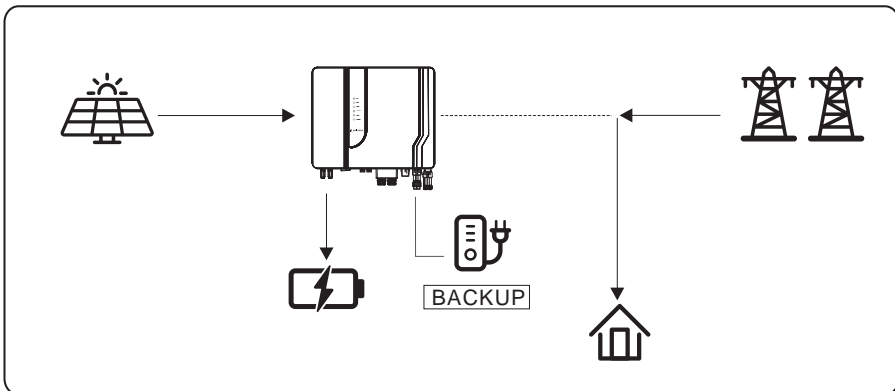

**Allow AC charging**

In this situation, the battery can be charged both with PV and AC.

**a) Wealthy PV power**

When PV energy is wealthy, PV charges the battery first, then meets the loads, and the rest is fed into the grid.

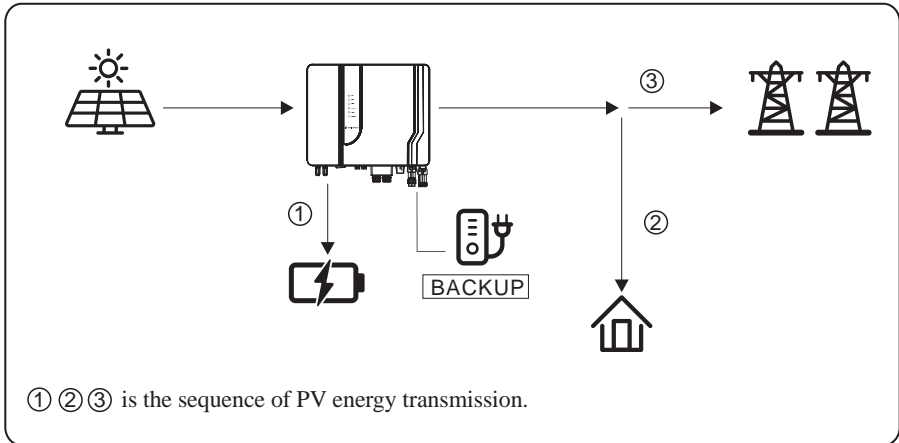

**b) Limited PV power**

When the PV energy is not enough to charge the battery, the grid energy will charge the battery as supplement. Meanwhile, the grid energy is consumed by loads.

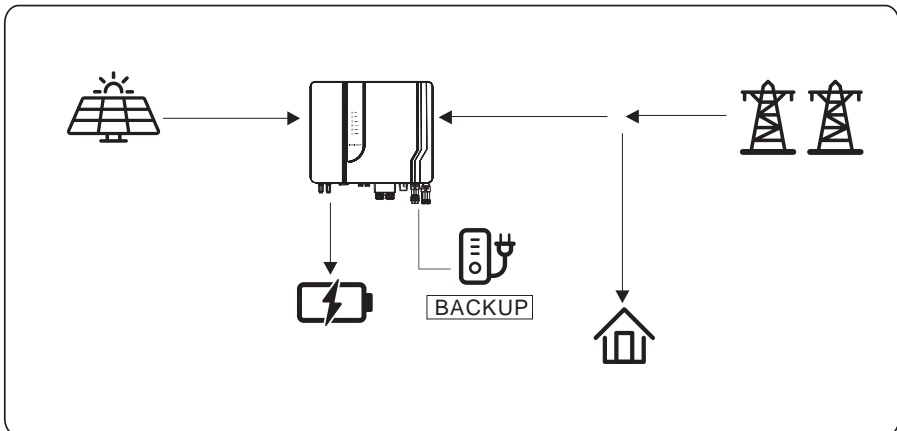

### 5.1.4 Off Grid Mode

When the power grid is cut off, the system automatically switches to Off Grid mode.

Under off-grid mode, only critical loads are supplied to ensure that important loads continue to work without power failure.

Under this mode, the inverter can't work without the battery.

#### a) Wealthy PV power

When PV energy is wealthy, the PV power will be first consumed by critical load, then charge the battery.

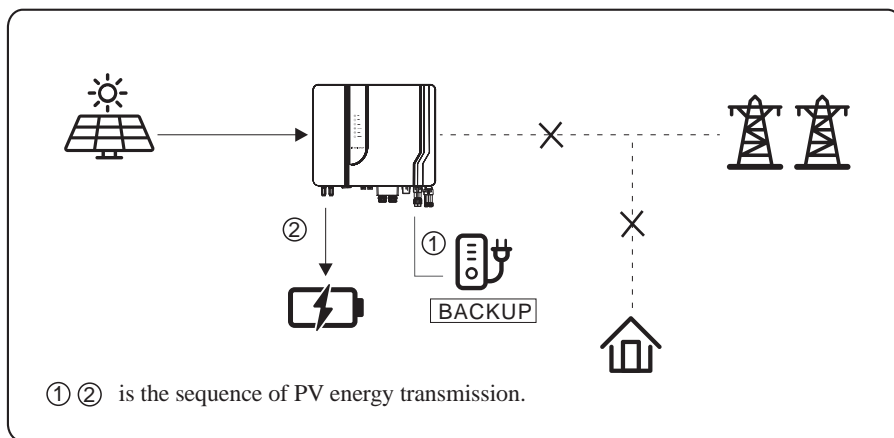

### b) Limited PV power

When PV energy is limited, BACKUP loads are first powered by PV and then supplemented by battery.

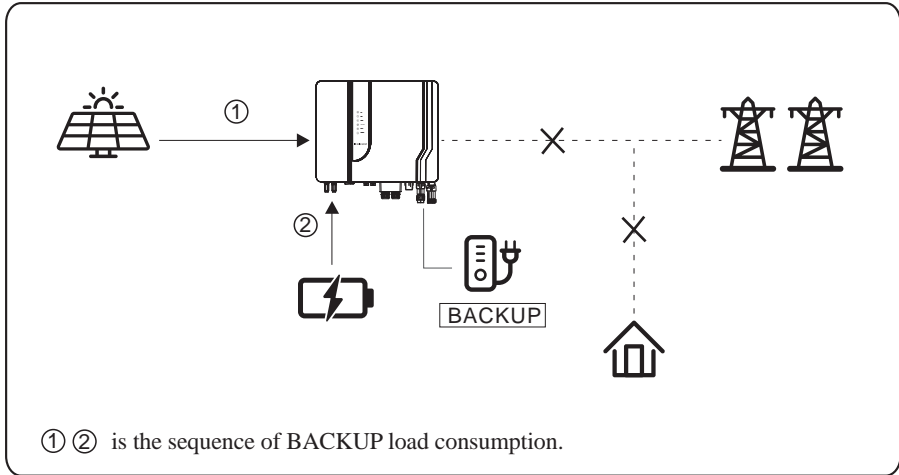

#### NOTICE

- Under this mode, please complete the output voltage and frequency settings.
- It is better to choose the battery capacity larger than 100Ah to ensure BACKUP function work normally.
- If BACKUP output loads are inductive or capacitive loads, to make sure the stability and reliability of system, it is recommended to configure the power of these loads to be within 50% BACKUP output power range.

## 5.2 Startup/Shutdown Procedure

### 5.2.1 Startup Procedure

Check that the installation is secure and strong enough, and that the system is well grounded. Then confirm the connections of AC, battery, PV etc. are correct. Confirm the parameters and configurations conform to relevant requirements.

AC Frequency	50/60Hz	PV Voltage	90~530V
Battery Voltage	42~60V	Grid AC Voltage	180~270V

Make sure all the above aspects are right, then follow the procedure to start up the inverter:

- 1) Power on PV.
- 2) Power on the Battery.
- 3) Power on the AC.
- 4) Power on the BACKUP.
- 5) Connect the cell phone App via Bluetooth. Please refer to Section 7.2 for details.
- 6) Click the Power ON in the App for the first time. Please refer to Section 7.2 for details.

### 5.2.2 Shutdown Procedure

According to actual situation, if there is a must to shut-down the running system, please follow below procedure:

- 1) Connect the cell phone App via Bluetooth. Please refer to Section 7.2 for details.
- 2) Click the Power OFF on the App. Please refer to Section 7.2 for details.
- 3) Power off the BACKUP.
- 4) Power off the AC.
- 5) Power off the Battery.
- 6) Power off the PV.
- 7) If you need to disconnect the inverter cables, please wait at least 10 minutes before touching these parts of inverter.

## **6. Commissioning**

It is necessary to make a complete commissioning of the inverter system. This will essentially protect the system from fire, electric shock or other damages or injuries.

### **6.1 Inspection**

Before commissioning, the operator or installer (qualified personnel) must inspect the system carefully and make sure:

- 1) The system is firmly and correctly installed by following the contents and notifications of this manual, and there are enough spaces for operation, maintenance and ventilation.
- 2) All the terminals and cables are in good status without any damages.
- 3) No items are left on the inverter or within the required clearance section.
- 4) The PV, battery pack is working normally, and grid is normal.

### **6.2 Commissioning Procedure**

After inspection and making sure status is right, then start the commissioning of the system.

- 1) Power on the system by referring to the Startup section 5.2.1.
- 2) Setting the parameters on the App according to user's requirement.
- 3) Finish commissioning.

## 7. User Interface

### 7.1 LED

This section describes the LED panel. LED indicator includes PV, BAT, GRID, BACKUP, COM, ALARM indicators. PV is N/A for AC couple. It includes the explanation of indicator states and summary of indicator states under the running state of the machine.

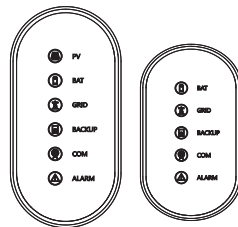

LED Indicator	Status	Description
PV	On	PV input is normal.
	Blink	PV input is abnormal.
	Off	PV is unavailable.
BAT	On	Battery is charging.
	Blink	Battery is discharging (light on 2s and off 2s). Battery is abnormal (light on 1s and off 1s).
	Off	Battery is unavailable.
GRID	On	GRID is available and normal.
	Blink	GRID is abnormal.
	Off	GRID is unavailable.
COM	Blink	Data are communicating.
	Off	No data transmission.
BACKUP	On	BACKUP power is available.
	Blink	BACKUP output is abnormal.
	Off	BACKUP power is unavailable.
ALARM	On	Fault has occurred and inverter shuts down.
	Blink	Alarm has occurred but inverter doesn't shut down.
	Off	No fault.

Details	Code	PV LED	Grid LED	BAT LED	BACKUP LED	COM LED	ALARM LED
PV normal		●	○	○	○	○	○
No PV		○	○	○	○	○	○
PV over voltage	B0						
PV under voltage	B4						
PV irradiation weak	B5	★	○	○	○	○	○
PV string reverse	B7						
PV string abnormal	B3						
On grid		○	●	○	○	○	○
Bypass output		○	●	○	○	○	○
Grid over voltage	A0						
Grid under voltage	A1						
Grid absent	A2						
Grid over frequency	A3						
Grid under frequency	A4	○	★	○	○	○	○
Grid abnormal	A6						
Grid over mean voltage	A7						
Neutral live wire reversed	A8						
Battery in charger		○	○	●	○	○	○
Battery absent	D1	○	○	○	○	○	○
Battery in discharge		○	○	★★	○	○	○
Battery under voltage	D3						
Battery over voltage	D2						
Battery discharge over current	D4	○	○	★	○	○	○
Battery over temperature	D5						
Battery under temperature	D6						
Communication loss (Inverter - BMS)	D8						
BACKUP output active		○	○	○	●	○	○
BACKUP output inactive		○	○	○	○	○	○
BACKUP short circuit	DB						
BACKUP over load	DC						
BACKUP output voltage abnormal	D7	○	○	○	★	○	○
BACKUP over dc-bias voltage	CP						

Details	Code	PV LED	Grid LED	BAT LED	BACKUP LED	COM LED	ALARM LED
RS485/DB9/BLE/USB		○	○	○	○	●	○
Inverter over temperature	C5						
Fan abnormal	C8						
Inverter in power limit state	CL						
Data logger lost	CH	○	○	○	○	○	★
Meter lost	CJ						
Remote off	CN						
PV insulation abnormal	B1						
Leakage current abnormal	B2						
Internal power supply abnormal	C0						
Inverter over dc-bias current	C2						
Inverter relay abnormal	C3						
GFCI abnormal	C6						
System type error	C7						
Unbalance Dc-link voltage	C9						
Dc-link over voltage	CA	○	○	○	○	○	●
Internal communication error	CB						
Internal communication loss(E-M)	D9						
Internal communication loss(M-D)	DA						
Software incompatibility	CC						
Internal storage error	CD						
Data inconsistency	CE						
Inverter abnormal	CF						
Boost abnormal	CG						
Dc-dc abnormal	CU						

Remark: ● Light on      ○ Light off      ◎ Keep original status  
 ★ Light on 1s and off 1s      ★★ Light on 2s and off 2s

## 7.2 App Setting Guide

### 7.2.1 Download App

- Scan the QR code on the inverter to download the APP.
- Download APP from the App Store or Google Play.

The APP should access some permissions such as device’s location. You need to grant all access rights in all pop-up windows when installing the APP or setting your phone.

### 7.2.2 App Architecture

It contains “Cloud Login” and “Local Connection”.

- Cloud login: APP read data from cloud server through API and display inverter parameter
- Local connection: APP read data from inverter through Bluetooth connection with Modbus protocol to display and configure inverter parameter.

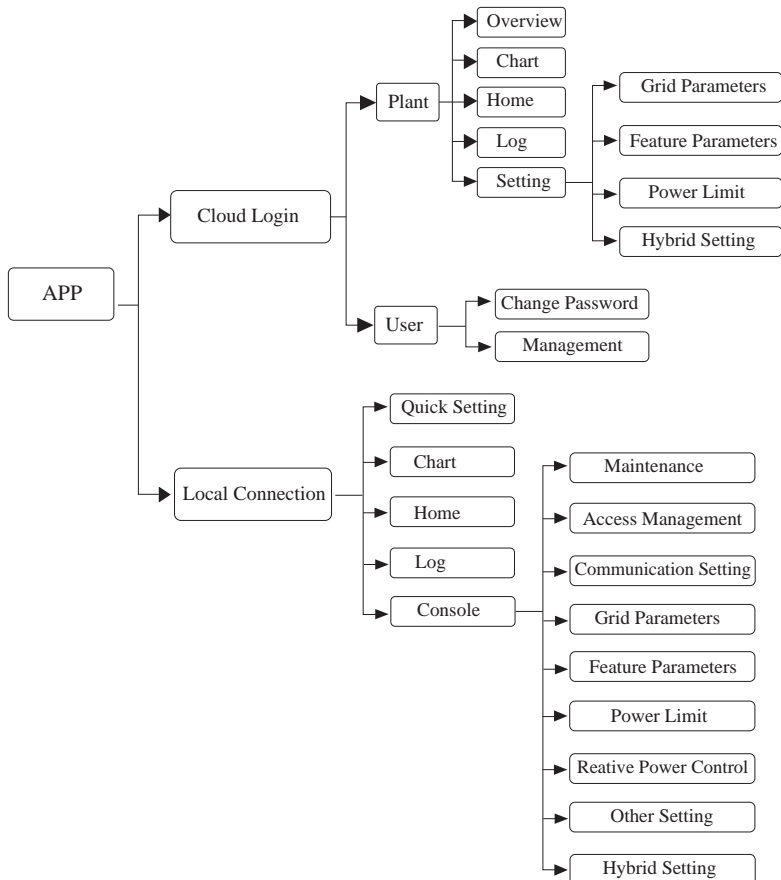

### 7.2.3 Local Setting

■ **Access Permission**

Before using the local setting, the APP should access some permissions. ( You need to grant all access rights in all pop-up windows when installing the APP or setting your phone.) When the APP asks for permission, please click “Allow”.

■ **Connect Inverter**

Firstly, open the Bluetooth on your own phone, then open the APP.

Press Local Setting to go to the connect page. This page shows the inverters which you can connect or you have connected. ( As shown below ) Press the inverter’s name to connect it.

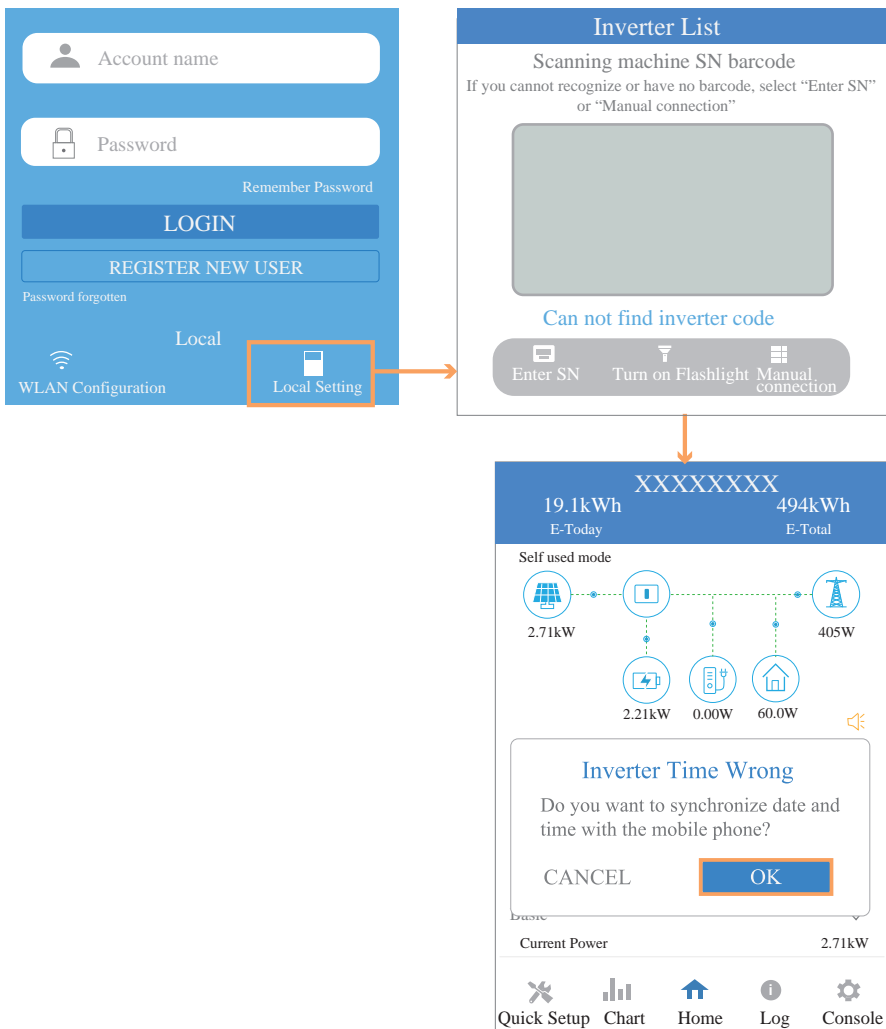

■ **Quick Setting**

1. Connect to the router.

Step 1 Go to Quick Setting page.

Step 2 Click each item to enter the informations, then click [Next](#).

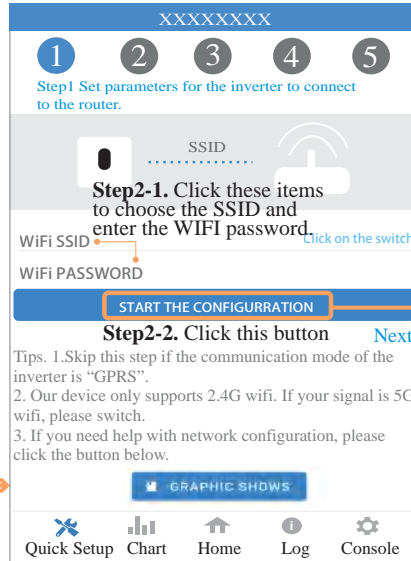
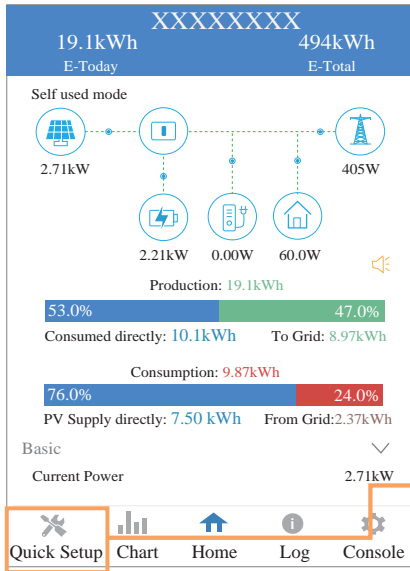

2. Set parameters of power grid

Step 1 Click each item to enter the parameters of power grid.

Step 2 Click [Next](#).

Step 3 Click [Previous](#) back to the previous page.

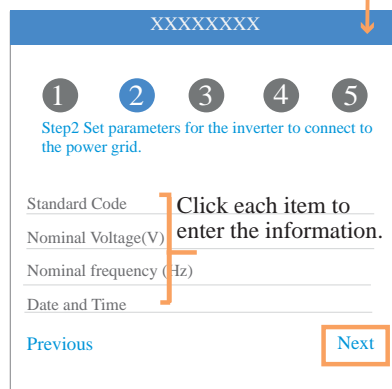

3. Set parameters of power limit

- Step 1 Click each item to enter the parameters of power limit.
- Step 2 Click [Next](#).
- Step 3 Click [Previous](#) back to the previous page.

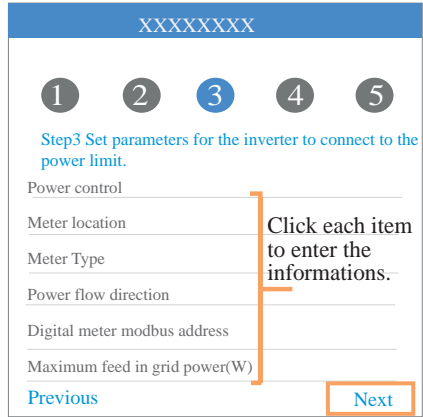

4. Set parameters of work mode

- Step 1 Click each item to enter the informations of work mode.
- Step 2 Click [Next](#).
- Step 3 Click [Previous](#) back to the previous page.

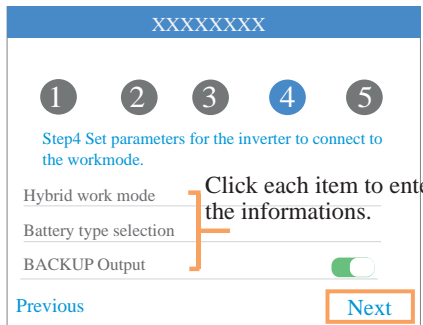

5. Start Inverter

- Step 1 Click .
- Step 2 Click [Previous](#) back to the previous page.



### ■ APP Power Chart

The power chart is showed by Day, Month and Year in our APP. For each exhibition method, it includes both Production and Consumption. We use different icons and colors for different power messages. The icon and color definition as below:



Color: Blue

Definition: Load consumption only from PV



Color: Red

Definition: Battery charge power with PV or AC



Color: Red

Definition: Battery discharge power for load consumption or feed-in grid



Color: Purple

Definition: Consumption power from grid



Color: Purple

Definition: Feed-in grid power from PV or battery



Color: Orange

Definition: Load power



Color: Orange

Definition: PV generating power

1. Query (Daily) Data

Go to [Chart](#) > [Day](#) page. It will show the Daily Production or Consumption Curve in this page. You can swipe the screen left and right to switch the graph.

● Day Chart--Production

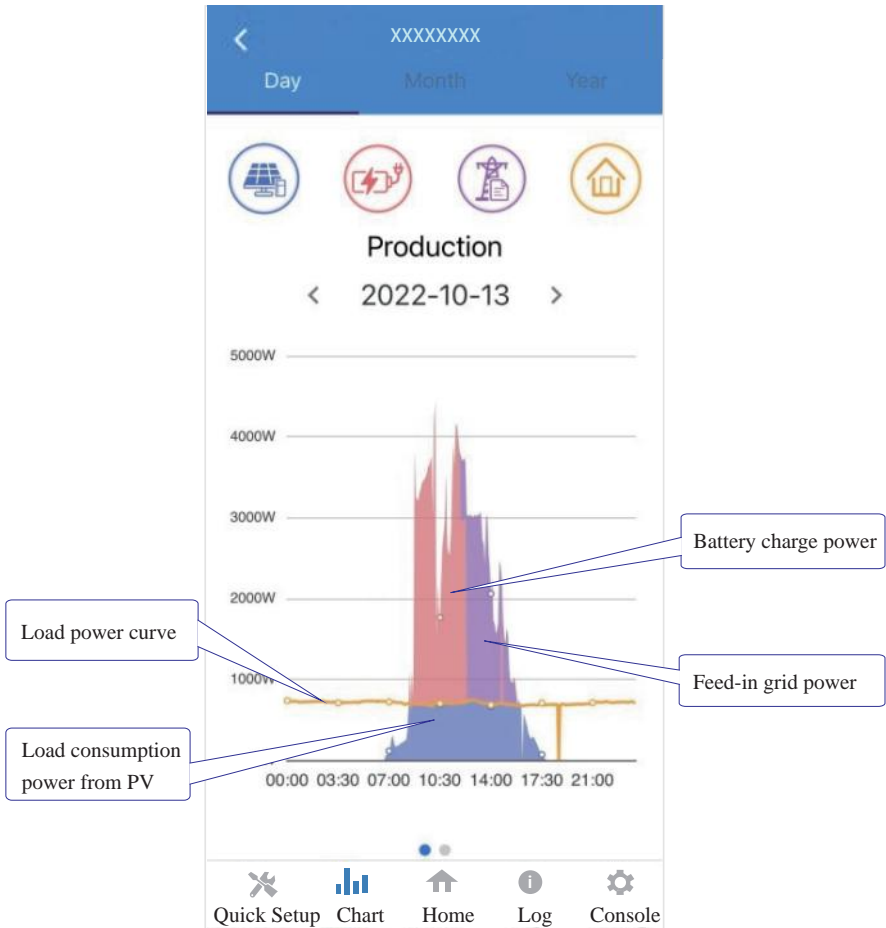

The above combination day chart shows the PV production power distributed with three parts:

- load consumption power (Blue)
- battery charge power (Red)
- feed-in grid power (Purple)

● Day Chart--Consumption



The above combination day chart shows the load consumption power from three parts:

- PV generation power (Blue)
- battery discharge power (Red)
- grid power (Purple)

Power supported by PV + power supported by battery + power supported by grid = Load consumption power.

2. Query (Monthly) Data

Go to [Chart](#) > [Month](#) page. It will show the Monthly Production or Consumption Curve in this page. You can swipe the screen left and right to switch the graph.

● Month Chart--Production

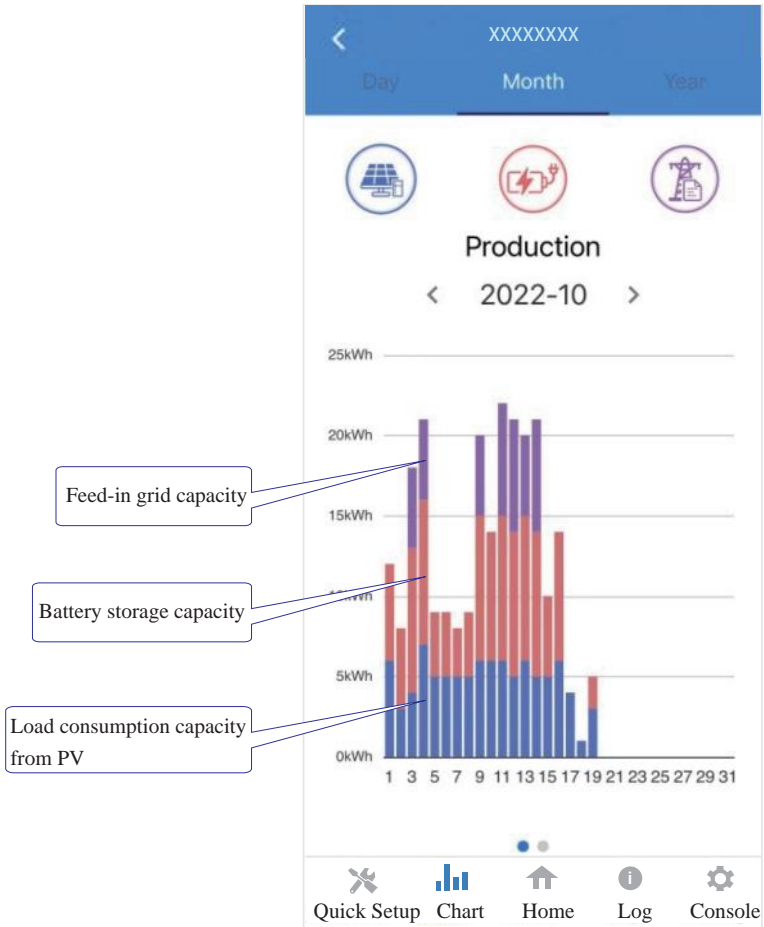

The above combination day chart shows the load consumption power from three parts:

- load consumption capacity (Blue)
- battery storage capacity (Red)
- feed-in grid capacity (Purple)

● Month Chart--Consumption

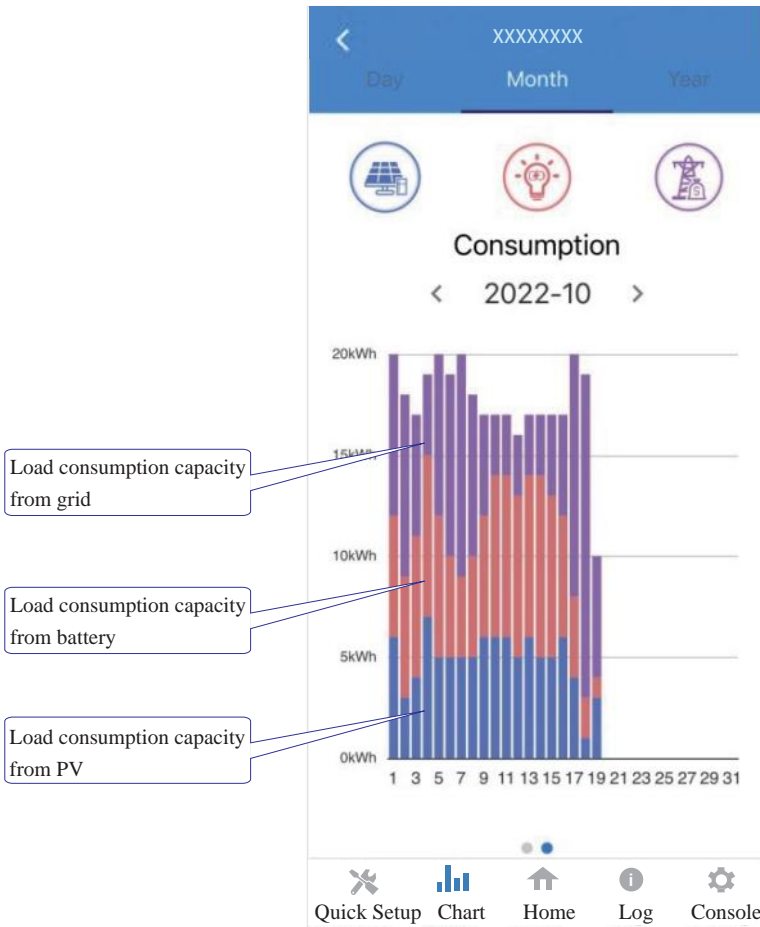

The above combination month chart shows the load consumption capacity from three parts:

- PV generation capacity (Blue)
- battery discharge capacity (Red)
- grid capacity (Purple)

2. Query (Yearly) Data

Go to [Chart](#) > [Year](#) page. It will show the Annually Production or Consumption Curve in this page. You can swipe the screen left and right to switch the graph.

● Year Chart--Production

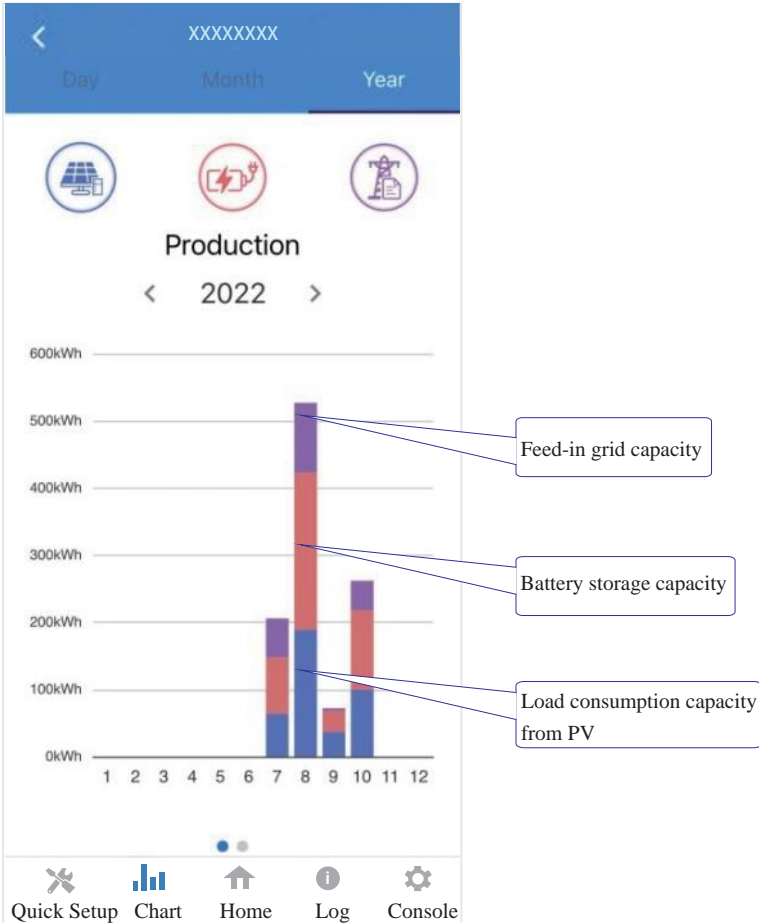

The above combination year chart shows the distribution of PV production capacity with three parts:

- load consumption capacity (Blue)
- battery storage capacity (Red)
- feed-in grid capacity (Purple)

● Year Chart--Consumption

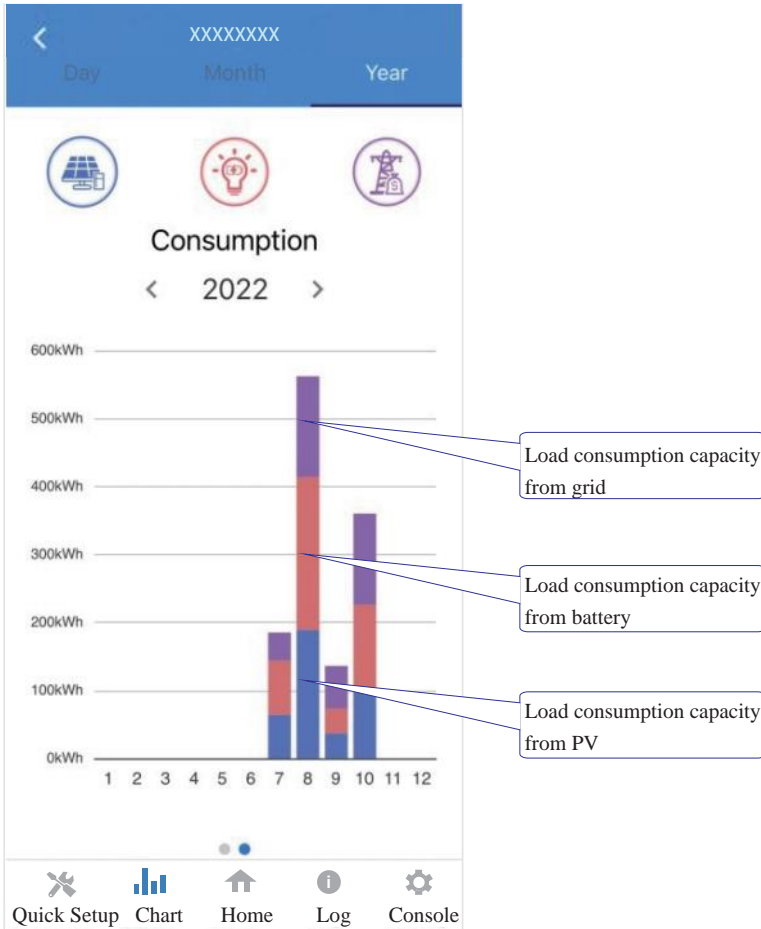

The above combination year chart shows the load consumption capacity from three parts:

- PV generation capacity (Blue)
- battery discharge capacity (Red)
- grid capacity (Purple)

■ **Local Setting Homepage**

This page shows the basic information of inverter. Click  to display the warning message.

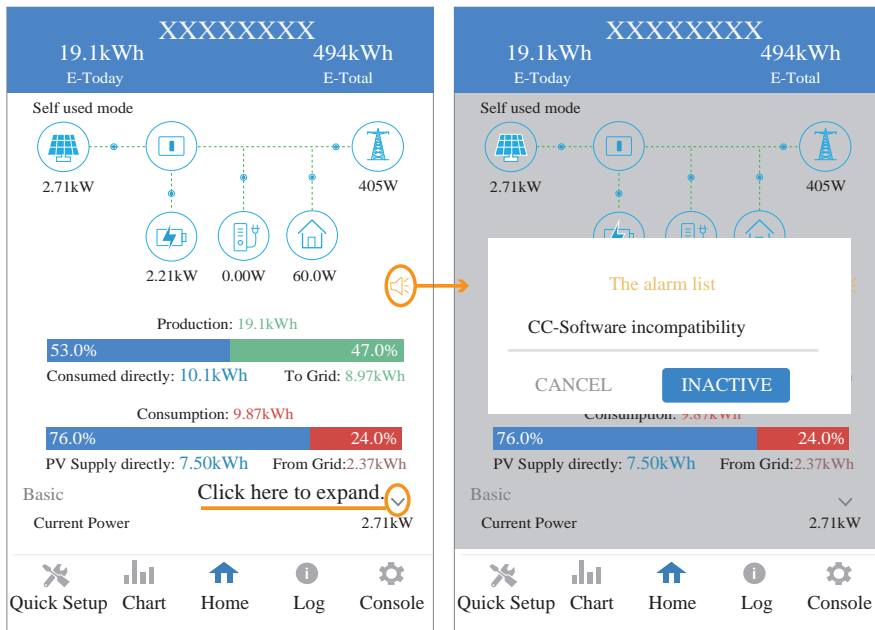

■ **History Log**

Press **Log** at the bottom and then go to the history log page ( as shown below ). It contains all the logs for the inverter.

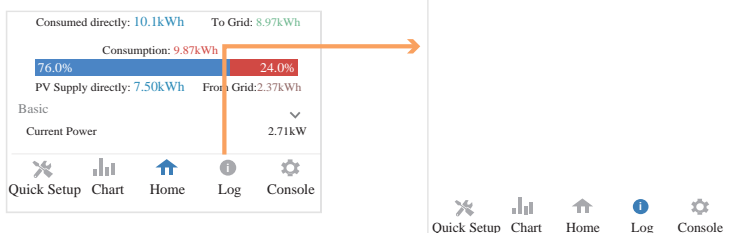

■ **Maintenance**

Go to [Console](#) page. And click [Maintenance](#)

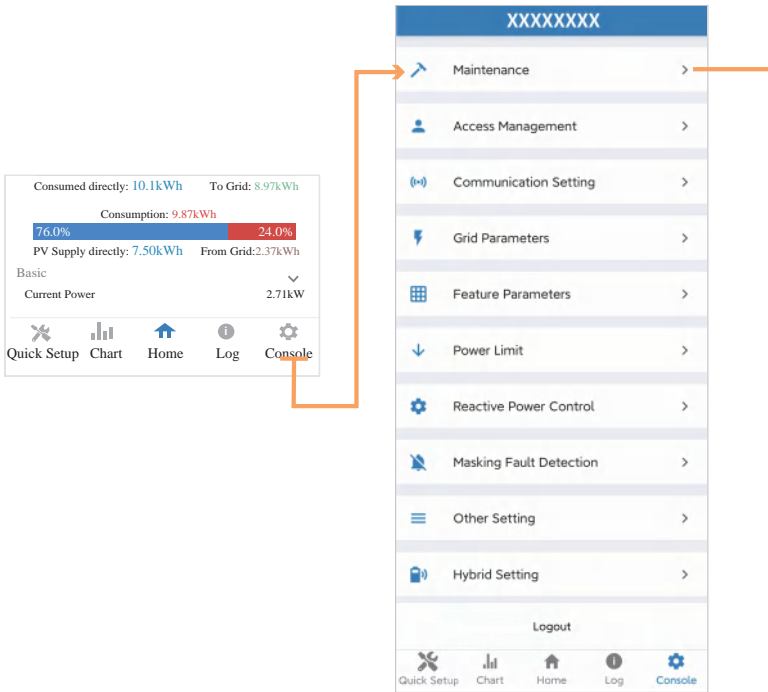

Then you need to enter password in a popup window (as shown below).

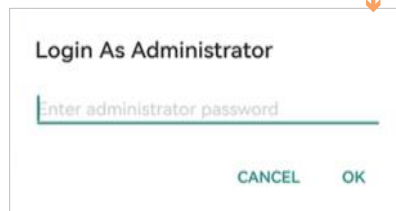

In this page, you can view the basic information like some version information, do some maintaining operations like turn off/on the inverter and manage data.

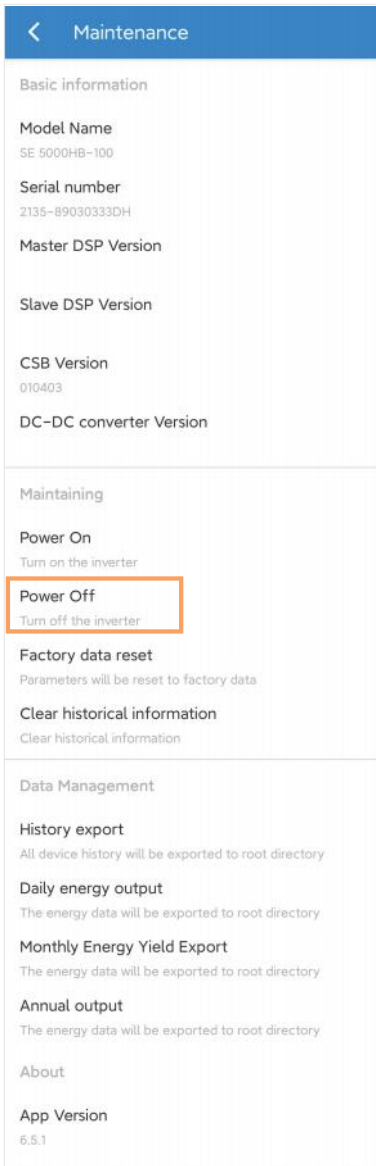

**< Maintenance**

Basic information

**Model Name**  
SE 5000HB-100

**Serial number**  
2135-89030333DH

**Master DSP Version**

**Slave DSP Version**

**CSB Version**  
010403

**DC-DC converter Version**

Maintaining

**Power On**  
Turn on the inverter

**Power Off**  
Turn off the inverter

**Factory data reset**  
Parameters will be reset to factory data

**Clear historical information**  
Clear historical information

Data Management

**History export**  
All device history will be exported to root directory

**Daily energy output**  
The energy data will be exported to root directory

**Monthly Energy Yield Export**  
The energy data will be exported to root directory

**Annual output**  
The energy data will be exported to root directory

About

**App Version**  
6.5.1

■ Console

**Access Management**

Go to [Console](#) > [Access Management](#) page. In this page, you can switch the login permission.

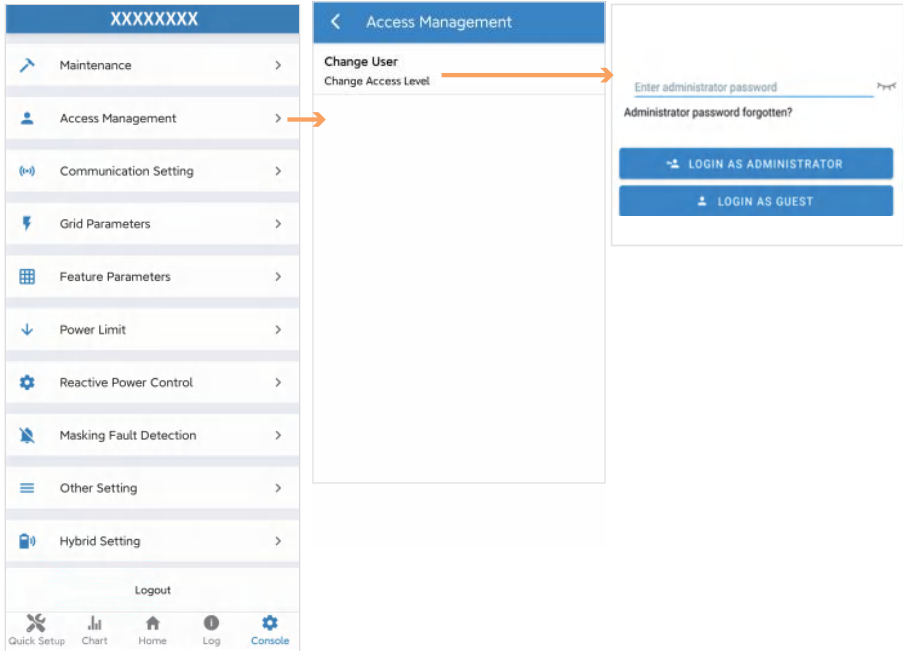

### Communication Setting

Go to [Console > Communication Setting](#) page. In this page, you can set or change the parameters of communication settings: Basic Setting, RS485 Setting and Ethernet Setting.

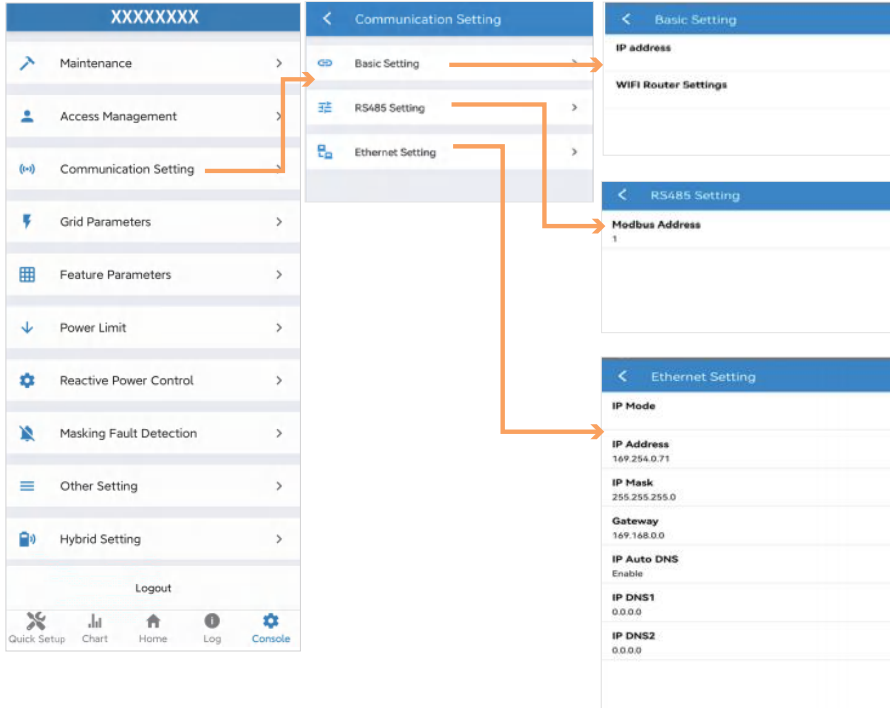

### Grid Parameters

Go to [Console](#) > [Grid Parameters](#) page. In this page, you can set or change the parameters of Grid side, as shown in the figure.

### Feature Parameters

Go to [Console](#) > [Feature Parameters](#) page. In this page, you can set or change the feature parameters, as shown in the figure.

### Power Limit

Go to [Console](#) > [Power Limit](#) page. In this page, you can set or change the parameters of power limit, as shown in the figure.

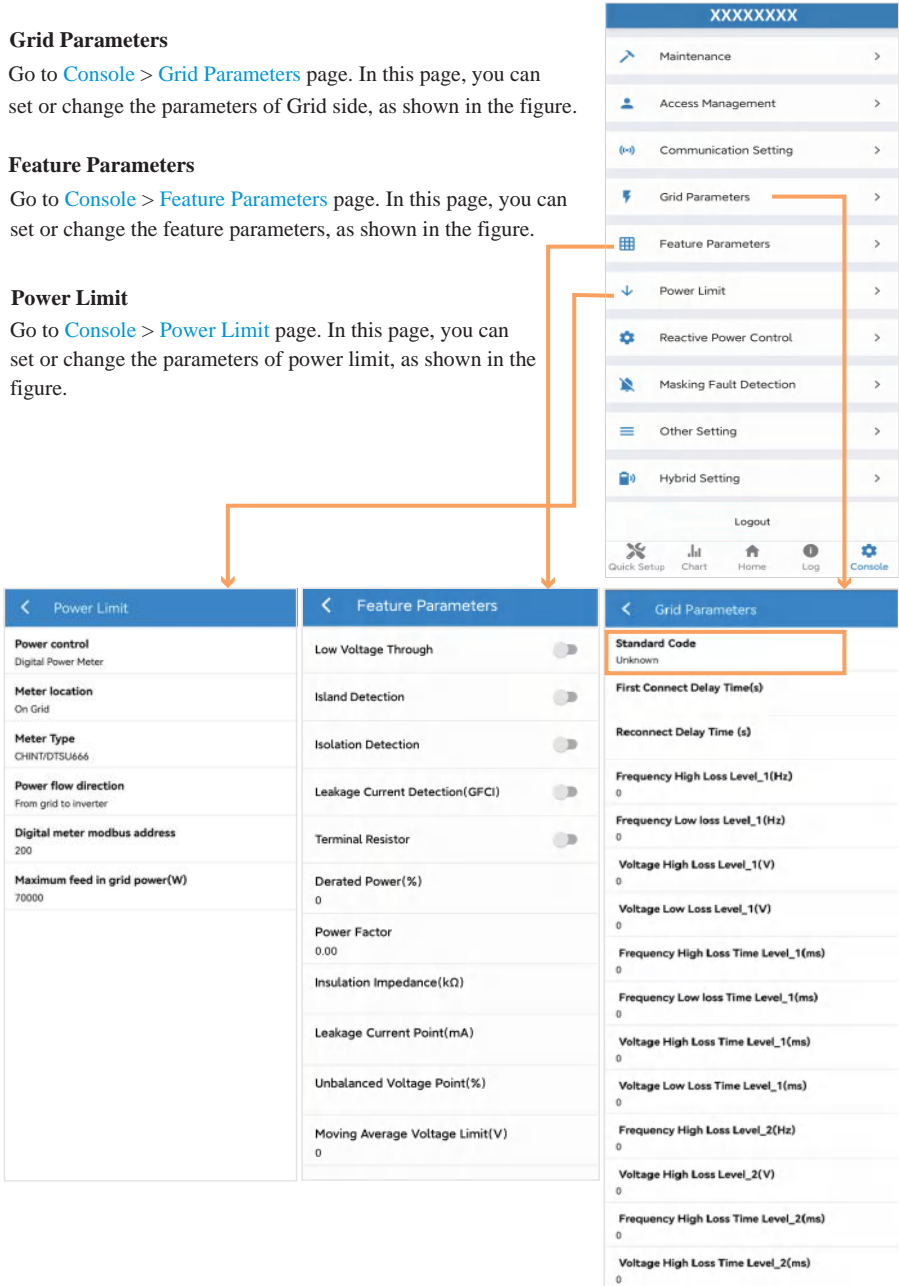

### How to Autotest?

- Step 1. Go to [Grid Parameters](#) > [Standard Code](#) page to select the IT (CEI 0-21).
- Step 2. Back to [Console](#) page. Refresh the page and enter the [Autotest](#) page to click **START**.
- Step 3. Then the inverter is autotesting. Wait for about 10 minutes, the autotest process will be finished.
- Step 4. You can click the [DOWNLOAD](#) to save the data file if necessary.

Note: if the [Autotest](#) option can't be turned out after the refresh in step 2. Please re-connect after logout. And then go to [Console](#) > [Autotest](#) page to click **START**.

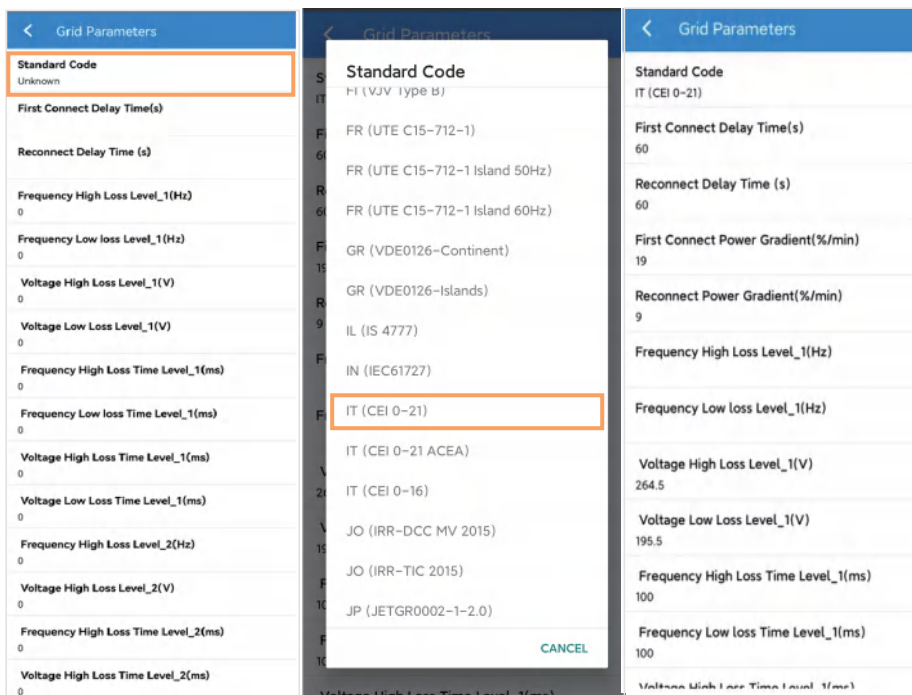

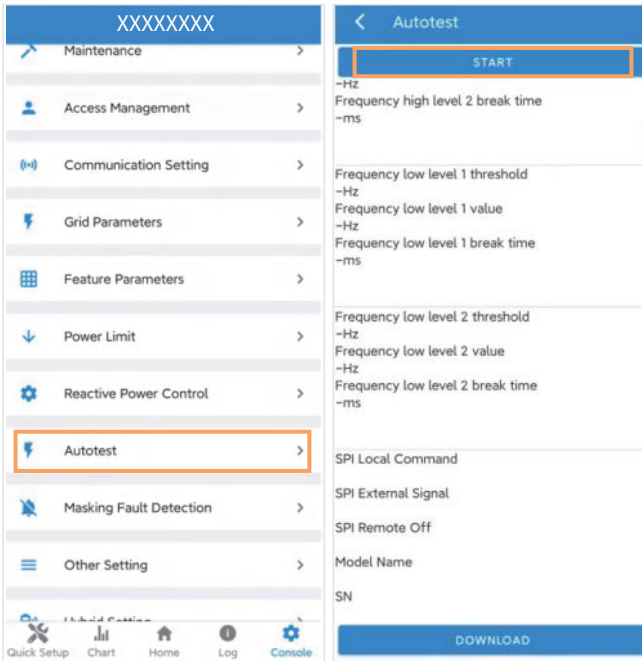

### Reactive Power Control

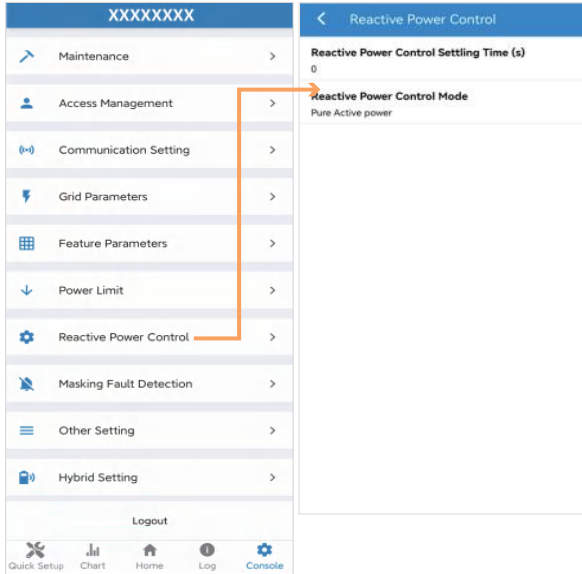

Go to [Console > Reactive Power Control](#) page. In this page, you can set or change the Reactive Power Control parameters.

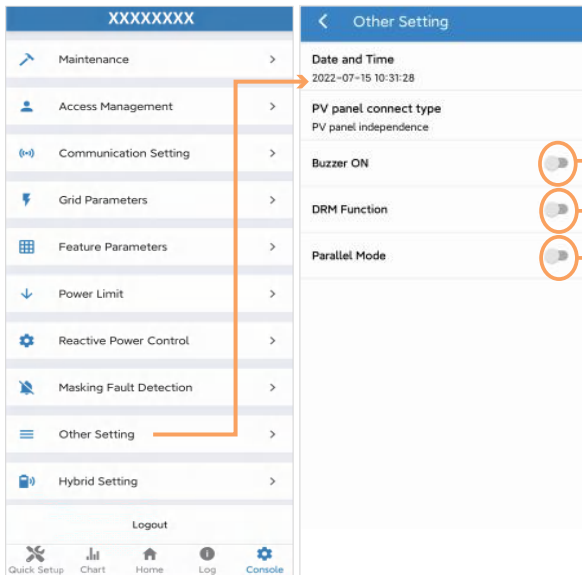

### Other Setting

Go to [Console > Other Setting](#) page. In this page, you can set other setting parameters.



-  Enable **Buzzer On** to open the Buzzer function.
-  Enable **DRM Function** to open the Buzzer function.
-  Enable **Parallel mode** when parallel connection.

## Hybrid Setting

Go to [Console > Hybrid Setting](#) page. In this page, you can set Hybrid Setting parameters.

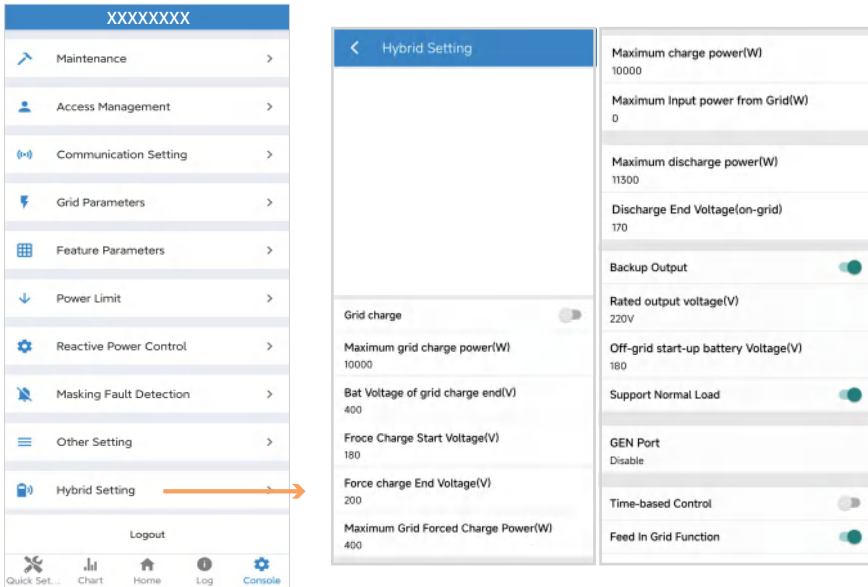

### --Grid charge

In [Hybrid Setting](#) page, you can choose whether to allow the grid to charge the battery, which is prohibited by default. If the user enables the "Grid charge" function, the parameter of "Maximum grid charge power" and "Bat Voltage of grid charge end" can be set. When the battery capacity reaches the set value, the grid will stop charging the battery.

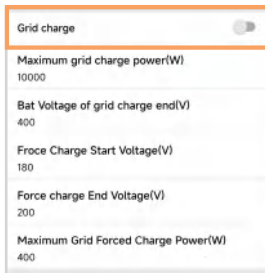

**--Time-based Control**

In [Hybrid Setting](#) page, you can also find “Time-based Control” function. This function is designed to control the time setting of charging and discharging the inverter. You can set the following parameters based on your requirements:

- Charge and discharge frequency: one time or daily
- Charging start time: 0 to 24 hours
- Charging end time: 0 to 24 hours
- Discharge start time: 0 to 24 hours
- Discharge end time: 0 to 24 hours

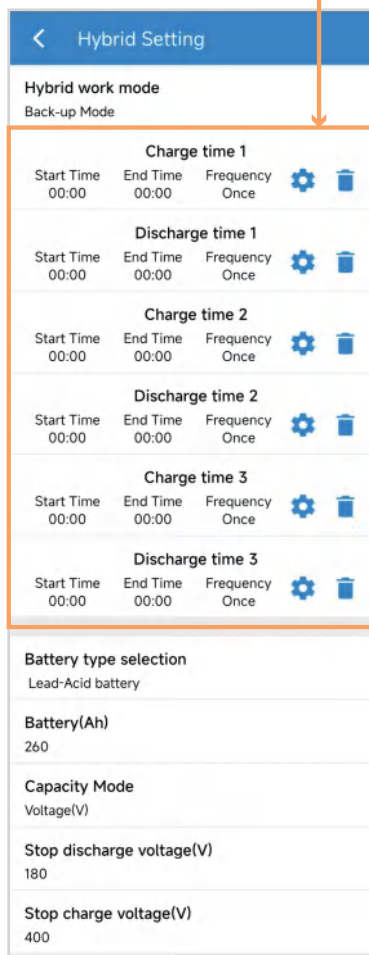
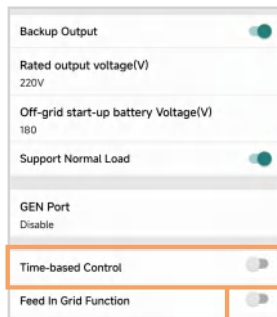

## 8. Maintenance

 <b>CAUTION</b>	<p>Before maintaining and commissioning inverter and its peripheral distribution unit, switch off all the charged terminals of the inverter and wait at least 10 minutes after the inverter is powered off.</p>
--	---

### 8.1 Routine Maintenance

Items	Check Content	Maintain Content	Maintenance Interval
Inverter output status	Statistically maintain the status of electrical yield, and remotely monitor its abnormal status.	N/A	Weekly
Inverter cleaning	Check periodically that the heat sink is free from dust and blockage.	Clean periodically the heat sink.	Yearly
Inverter running status	Check that the inverter is not damaged or deformed. Check for normal sound emitted during inverter operation. Check and ensure that all inverter communications is running well.	If there is any abnormal phenomenon, replace the relevant parts.	Monthly
Inverter electrical connections	Check that all AC, DC and communication cables are securely connected; Check that PGND cables are securely connected; Check that all cables are intact and free from aging.	If there is any abnormal phenomenon, replace the cable or re-connect it.	Semiannually

## 8.2 Inverter Troubleshooting

When the inverter has an exception, its basic common warning and exception handling methods are shown below.

Code	Alarm Information	Suggestions
A0	Grid over voltage	1. If the alarm occurs occasionally, possibly the power grid voltage is abnormal for a short time, and no action is required. 2. If the alarm occurs repeatedly, contact the local power station. After receiving approval of the local power bureau, revise the electrical protection parameters settings on the inverter through the App. 3. If the alarm persists for along time, check whether the AC circuit breaker /AC terminals is disconnected or not, or if the grid has a power outage.
A1	Grid under voltage	
A3	Grid over frequency	
A4	Grid under frequency	
A2	Grid absent	Wait till power is restored.
B0	PV over voltage	Check whether the maximum voltage of a single string of input PV module is greater than the allowable voltage. If the maximum voltage is higher than the standard voltage, modify the number of pv module connection strings.
B1	PV insulation abnormal	1. Check the insulation resistance against the ground for the PV strings. If a short circuit has occurred, rectify the fault. 2. If the insulation resistance against the ground is less than the default value in a rainy environment, set insulation resistance protection on the App.
B2	Leakage current abnormal	1. If the alarm occurs occasionally, the inverter can be automatically recovered to the normal operating status after the fault is rectified. 2. If the alarm occurs repeatedly, contact your dealer for technical support.
B4	PV under voltage	1. If the alarm occurs occasionally, possibly the external circuits are abnormal accidentally. The inverter automatically recovers to the normal operating status after the fault is rectified. 2. If the alarm occurs repeatedly or last a long time, check whether the insulation resistance against the ground of PV strings is too low.
C0	Internal power supply abnormal	1. If the alarm occurs occasionally, the inverter can be automatically restored, no action required. 2. If the alarm occurs repeatedly, pls. contact the customer service center.

C2	Inverter over dc-bias current	<ol style="list-style-type: none"> <li>1. If the alarm occurs occasionally, possibly the power grid voltage is abnormal for a short time, and no action is required.</li> <li>2. If the alarm occurs repeatedly, and the inverter fails to generate power, contact the customer service center.</li> </ol>
C3	Inverter relay abnormal	<ol style="list-style-type: none"> <li>1. If the alarm occurs occasionally, possibly the power grid voltage is abnormal for a short time, and no action is required.</li> <li>2. If the alarm occurs repeatedly, pls. refer to the suggestions or measures of Grid over voltage. and the inverter fails to generate power, contact the customer service center. If there is no abnormality on the grid side, the machine fault can be determined. (If you open the cover and find traces of damage to the relay, it can be concluded that the machine is faulty.) And pls. contact the customer service center.</li> </ol>
CN	Remote off	<ol style="list-style-type: none"> <li>1. Local manual shutdown is performed in APP.</li> <li>2. The monitor executed the remote shutdown instruction.</li> <li>3. Remove the communication module and confirm whether the alarm disappears. If it does, replace the communication module. Otherwise, please contact the customer service center.</li> </ol>
C5	Inverter over temperature	<ol style="list-style-type: none"> <li>1. If the alarm occurs occasionally, the inverter can be automatically restored, no action required.</li> <li>2. If the alarm occurs repeatedly, pls. check the installation site for direct sunlight, good ventilation, and high ambient temperature (Such as installed on the parapet). If the ambient temperature is lower than 45 ° C and the heat dissipation is good, contact the customer service center.</li> </ol>
C6	GFCI abnormal	<ol style="list-style-type: none"> <li>1. If the alarm occurs occasionally, it could have been an occasional exception to the external wiring, the inverter can be automatically recovered, no action required.</li> <li>2. If it occurs repeatedly or cannot be recovered for a long time, pls. contact customer service to report repair.</li> </ol>
B7	PV string reverse	Check and modify the positive and negative polarity of the input of the circuit string.
C8	Fan abnormal	<ol style="list-style-type: none"> <li>1. If the alarm occurs occasionally, pls. restart the inverter.</li> <li>2. If it occurs repeatedly or cannot be recovered for a long time, check whether the external fan is blocked by foreign objects. Otherwise, contact customer service.</li> </ol>
C9	Unbalance Dc-link voltage	<ol style="list-style-type: none"> <li>1. If the alarm occurs occasionally, the inverter can be automatically recovered and no action is required.</li> </ol>
CA	Dc-link over voltage	<ol style="list-style-type: none"> <li>2. If the alarm occurs repeatedly, the inverter cannot work properly. Pls. contact the customer service center.</li> </ol>

CB	Internal communication error	<ol style="list-style-type: none"> <li>1. If the alarm occurs occasionally, the inverter can be automatically recovered and no action is required.</li> <li>2. If the alarm occurs repeatedly, the inverter cannot work properly. Pls. contact the customer service center.</li> </ol>
CC	Software incompatibility	<ol style="list-style-type: none"> <li>1. If the alarm occurs occasionally, the inverter can be automatically recovered and no action is required.</li> <li>2. If the alarm occurs repeatedly, the inverter cannot work properly. Pls. contact the customer service center.</li> </ol>
CD	Internal storage error	<ol style="list-style-type: none"> <li>1. If the alarm occurs occasionally, the inverter can be automatically recovered and no action is required.</li> <li>2. If the alarm occurs repeatedly, the inverter cannot work properly. Pls. contact the customer service center.</li> </ol>
CE	Data inconsistency	<ol style="list-style-type: none"> <li>1. If the alarm occurs occasionally, the inverter can be automatically recovered and no action is required.</li> <li>2. If the alarm occurs repeatedly, the inverter cannot work properly. Pls. contact the customer service center.</li> </ol>
CF	Inverter abnormal	<ol style="list-style-type: none"> <li>1. If the alarm occurs occasionally, the inverter can be automatically recovered and no action is required.</li> <li>2. If the alarm occurs repeatedly, the inverter cannot work properly. Pls. contact the customer service center.</li> </ol>
CG	Boost abnormal	<ol style="list-style-type: none"> <li>1. If the alarm occurs occasionally, the inverter can be automatically recovered and no action is required.</li> <li>2. If the alarm occurs repeatedly, the inverter cannot work properly. Pls. contact the customer service center.</li> </ol>
CJ	Meter lost	<ol style="list-style-type: none"> <li>1. Check the meter parameter Settings</li> <li>2. Local APP checks that the communication address of the inverter is consistent with that of the electricity meter</li> <li>3. The communication line is connected incorrectly or in bad contact</li> <li>4. electricity meter failure.</li> <li>5. Exclude the above, if the alarm continues to occur, please contact the customer service center.</li> </ol>
P1	Parallel ID warning	It is Parallel ID Alarm. Pls. check the parallel communication cable, and check whether any inverter joins or exits online. All inverters are powered off completely, check the line, and then power on the inverters again to ensure that the alarm is cleared.
P2	Parallel SYN signal warning	Parallel synchronization signal is abnormal. Check whether the parallel communication cable is properly connected.
P3	Parallel BAT abnormal	The parallel battery is abnormal. Whether the battery of the inverter is reported low voltage or the battery is not connected.
P4	Parallel GRID abnormal	The parallel grid is abnormal. Whether the grid of the inverter is abnormal.

D2	Battery over voltage	<ol style="list-style-type: none"> <li>1. If the alarm occurs occasionally, the inverter can be automatically recovered and no action is required.</li> <li>2. Check that the battery overvoltage protection value is improperly set.</li> <li>3. The battery is abnormal.</li> <li>4. If exclude the above, the alarm continues to occur, please contact the customer service center.</li> </ol>
D3	Battery under voltage	<ol style="list-style-type: none"> <li>1. If the alarm occurs occasionally, the inverter can be automatically recovered and no action is required.</li> <li>2. Check the communication line connection between BMS and inverter (lithium battery).</li> <li>3. The battery is empty or the battery voltage is lower than the SOC cut-off voltage.</li> <li>4. The battery undervoltage protection value is improperly set.</li> <li>5. The battery is abnormal.</li> <li>6. If exclude the above, the alarm continues to occur, please contact the customer service center.</li> </ol>
D4	Battery discharger over current	<ol style="list-style-type: none"> <li>1. Check whether the battery parameters are correctly set.</li> <li>2. Battery undervoltage.</li> <li>3. Check whether a separate battery is loaded and the discharge current exceeds the battery specifications.</li> <li>4. The battery is abnormal.</li> <li>5. If exclude the above, the alarm continues to occur, please contact the customer service center.</li> </ol>
D5	Battery over temperature	<ol style="list-style-type: none"> <li>1. If the alarm occurs repeatedly, please check whether the installation site is in direct sunlight and whether the ambient temperature is too high (such as in a closed room).</li> </ol>
D6	Battery under temperature	<ol style="list-style-type: none"> <li>2. If the battery is abnormal, replace it with a new one.</li> <li>3. If exclude the above, the alarm continues to occur, please contact the customer service center.</li> </ol>
D7	BACKUP output voltage abnormal	<ol style="list-style-type: none"> <li>1. Check whether the BACKUP voltage and frequency Settings are within the specified range.</li> <li>2. Check whether the BACKUP port is overloaded.</li> <li>3. When not connected to the power grid, check whether BACKUP output is normal.</li> <li>4. If exclude the above, the alarm continues to occur, please contact the customer service center.</li> </ol>
D8	Communication error (Inverter-BMS)	<ol style="list-style-type: none"> <li>1. Check whether the battery is disconnected.</li> <li>2. Check whether the battery is well connected with the inverter.</li> <li>3. Confirm that the battery is compatible with the inverter. It is recommended to use CAN communication.</li> <li>4. Check whether the communication cable or port between the battery and the inverter is faulty.</li> <li>5. If exclude the above, the alarm continues to occur, please contact the customer service center.</li> </ol>

D9	Internal communication loss(E-M)	1. Check whether the communication cables between BACKUP, electricity meter and inverter are well connected and whether the wiring is correct 2. Check whether the communication distance is within the specification range
DA	Internal communication loss(M-D)	3. Disconnect the external communication and restart the electricity meter and inverter. 4. If exclude the above, the alarm continues to occur, please contact the customer service center.
CU	Dcdc abnormal	1. If the alarm occurs occasionally, the inverter can be automatically recovered and no action is required. 2. If the alarm occurs repeatedly, please check: 1) Check whether the MC4 terminal on the PV side is securely connected. 2) Check whether the voltage at the PV side is open circuit, ground to ground, etc. If exclude the above, the alarm continues to occur, please contact the customer service center.
CP	BACKUP over dc-bias voltage	1. If the alarm occurs occasionally, the inverter can be automatically recovered and no action is required. 2. If the alarm occurs repeatedly, the inverter cannot work properly. Pls. contact the customer service center.
DB	BACKUP short circuit	1. Check whether the live line and null line of BACKUP output are short-circuited. 2. If it is confirmed that the output is not short-circuited or an alarm, please contact customer service to report for repair. (After the troubleshooting of alarm problems, BACKUP switch needs to be manually turned on during normal use.)
DC	BACKUP over load	1. Disconnect the BACKUP load and check whether the alarm is cleared. 2. If the load is disconnected and the alarm is generated, please contact the customer service. (After the alarm is cleared, the BACKUP switch needs to be manually turned on for normal use.)

### 8.3 Removing the Inverter



#### WARNING

Before removing DC input connector, double check DC input switch is turned to OFF to avoid inverter damage and personal injury.

Perform the following procedures to remove the inverter:

Step 1. Disconnect all cables from the inverter, including communications cables, DC input power cables, AC output power cables, and PGND cable, as shown below.

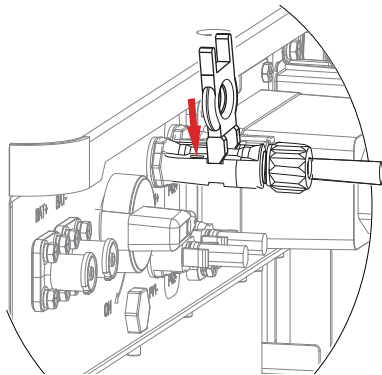

PV Connectors Removing Detail



#### NOTE

To remove the PV/GRID/BACKUP connectors, insert the removal tool into the bayonet according to the position indicated in the drawing, press inward, and then take out the connector outward.

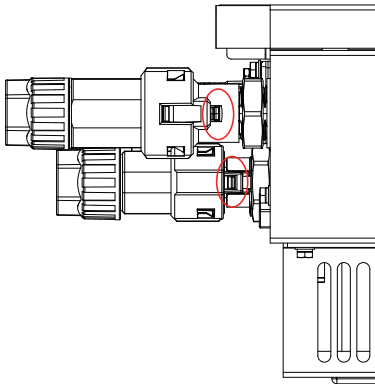

GRID/BACKUP Connectors Removing Detail

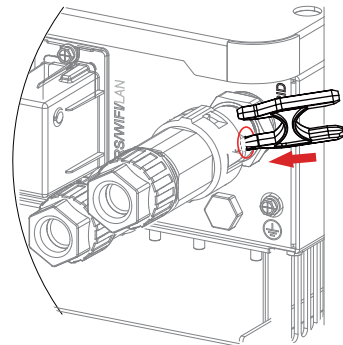

Step 2. Remove the inverter from the mounting bracket.

Step 3. Remove the mounting bracket.