



## Rechargeable HV Battery System User Manual

# Contents

---

Statement.....	1
Safety handling of lithium batteries Guide.....	2
1. Introduction.....	4
1.1 Brief Introduction.....	4
1.2 Product Features.....	4
1.3 Product identity definition.....	5
2. Specification.....	6
2.1 System Performance Parameter.....	6
2.2 Battery Module.....	7
2.3 Controller.....	9
2.4 Base.....	12
3. Installation.....	14
3.1 Environmental Requirement.....	14
3.2 Recommended Installation clearance.....	15
3.3 Tools.....	16
3.4 Safety Gear.....	16
3.5 Unpacking inspection.....	16
3.6 Installation.....	18
4. Maintenance.....	27
4.1 Trouble Shooting.....	27
4.2 Replacement of main component.....	28
4.3 Battery Maintenance.....	28
5. Storage Recommendations.....	29
6. Shipment.....	29

## Statement

---

Copyright of this document belongs to BEXIE GROUP S.L.

No part of this documentation maybe excerpted, reproduced, translated, annotated or duplicated in any form or by any means without the prior written authorization of BEXIE GROUP S.L. All Rights Reserved.

This product complies with the design requirements of environmental protection and personal safety. The storage, use and disposal of the products shall be carried out in accordance with the product manual, relevant contract or relevant laws and regulations.

Customer can check the related information on the website of BEXIE GROUP S.L. when the product or technology is updated.

Please note that the product can be modified without prior notification.

## Revision History

Date	Revision	Description	Owner
2024.04.19	V1.0	First Published	Guangan.he
2024.09.03	V1.1	Content correction	WR Wu

# Safety handling of lithium batteries Guide

## Symbols

 **DANGER**

- Battery strings will produce high voltage DC power and can cause a lethal voltage and electric shock.
- Only qualified person can perform the wiring of the battery strings.

 **WARNING**

- Risk of battery system damage or personal injury.
- DO NOT pull out the connectors while the system is operating!
- De-energize from all multiple power sources and verify that there is no voltage.

 **CAUTION**

- Risk of battery system failure or life cycle reduction.



Warning:

This product is a high voltage DC system, operated by authorized person only.



Danger:

Before installation or operation you must read <User Menu> carefully.



Caution:

Before Connecting

- Please check product and packing list first after unpacking, if product is damaged or lack of parts, please contact with the local retailer;
- Before installation, be sure to cut off the grid power and make sure the battery is in the turned-off mode; Do not mistake the positive and negative cables and ensure there are no short circuit connection to the
- external device;
  - It is prohibited to connect the battery to AC power directly;
- Battery system must be well grounded;
- Please ensured the electrical parameters of battery system are compatible to related equipment;
- Keep the battery away from water and fire.
-

## In Using

- If the battery system needs to be moved or repaired, the power must be cut off and ensure the battery is completely shut down;
- It is prohibited to connect the battery with different type of battery.
- It is prohibited to put the batteries working with faulty or incompatible inverter;
- It is prohibited to disassemble the battery (Warranty tab removed or damaged);
- In case of fire, only dry powder fire extinguisher can be used, liquid fire extinguishers are prohibited;
- Please do not open, repair or disassemble the battery except staffs from BEXIE or authorized by BEXIE. We do not undertake any consequences or related responsibility which because of violation of safety operation or equipment safety standards.



### Caution:

- Please read the user manual carefully (in the accessories);
- If the battery is stored for a long time, it is required to charge them every six months, and the SOC should be no less than 80%;
- Battery needs to be recharged within 12 hours, after fully discharged;
- Do not expose cable outside;
- All the battery terminals must be disconnected for maintenance;
- Please contact the supplier within 24 hours if there is something abnormal.
- The warranty claims are excluded for direct or indirect damage due to items above.

# 1 Introduction

---

## 1.1 Brief Introduction

HV Battery Pack is a high voltage battery storage system based on lithium iron phosphate battery, and it's one of the new energy storage products developed and produced by HV Battery Pack, it can be used to support reliable power for various types of equipments and systems. HV Battery Pack is especially suitable for application scene of high power, limited installation space, restricted load-bearing and long cycle life.

## 1.2 Product Features

- The whole module is non-toxic, non-polluting and environmentally friendly;
- Anode material is made from  $\text{LiFePO}_4$  with safety performance and long cycle life;
- Battery management system (BMS) has protection functions including over-discharge, over-charge, over-current and high/low temperature;
- The system can automatically manage charge and discharge state and balance current and voltage of each cell;
- Flexible configuration, multiple battery modules can be in serial for expanding voltage and Capacity. Adopted natural cooling reduced system entire noise;
- The module has less self-consumption, up to 6 months without charging; no memory effect, excellent performance of shallow charge and discharge;  
Working temperature range is from  $-15$  to  $55^\circ\text{C}$ , with excellent discharge performance and cycle life;
- Small size and light weight, standard module is comfortable for installation and maintenance;

-

### 1.3 Product identity definition

Figure 1-1 Battery System nameplate

**BEXIE GROUP**

Rechargeable HV Battery System  
 BMS Controller Model : BXBC 5KHV  
 Operation Temp : -15°C~55°C  
 Input / Output Current : 30A  
 Protection Class : I  
 IP Grade : IP55

Configuration/Nominal Voltage/Rated Capacity/Energy/System Model

1S / 102.4Vdc / 50Ah / 5.12kWh / BXB 5KHV  
 2S / 204.8Vdc / 50Ah / 10.24kWh / BXB 10KHV  
 3S / 307.2Vdc / 50Ah / 15.36kWh / BXB 15KHV  
 4S / 409.6Vdc / 50Ah / 20.48kWh / BXB 20KHV  
 5S / 512.0Vdc / 50Ah / 25.60kWh / BXB 25KHV  
 6S / 614.4Vdc / 50Ah / 30.72kWh / BXB 30KHV

SN: 

U C B 7 00 050 R2A 22 8 C 0001

BEXIE GROUP S.L.  
 Email: info@bexiegroup.com  
 Tel: 34 985 194232  
 Address: CALLE COVADONGA 5 – 33002 OVIEDO (ASTURIAS)

  
**MADE IN CHINA**

Figure 1-2 Battery module label

**BEXIE GROUP**

Product Name:	HV Battery Pack
Model:	BXBM 5KHV
Rated Energy/Voltage:	5.12kWh/102.4Vdc
Rated Capacity:	50Ah
Operation Voltage Range:	89.6Vdc to 116.8Vdc
Input / Output Current :	30A(0.6C)
Charging Temperature:	-5°C to 55°C
Discharging Temperature:	-15°C to 55°C
Dimension(W*D*H):	560*400*273mm
IP Grade:	IP55

**CAUTION**

- \* Do not disassemble the battery pack.
- \* Do not immerse the battery pack in water.
- \* Do not short-circuit the battery.
- \* Do not leave the battery near by fire.

**Emergency Situations**

- \* If leaking, fire, wet, or damaged, switch off the breaker on the DC side and stay away from the battery.
- \* Do not touch the leaking liquid.
- \* Do not use water to extinguish the fire, Sand or dry powder extinguisher is usable.

SN: 

U H F 102 050 A 0 8 22 9 1 0001

  
**MADE IN CHINA**

BEXIE GROUP S.L.  
 CALLE COVADONGA 5 – 33002 OVIEDO (ASTURIAS)

The definition of SN: UHF102050A0022910001	
UHFF	Product type
102	Voltage
050	Capacity
A00	Platform type
22	Year of production
9	Month of production
1	Day of production
0001	Batch number of production

## 2 Specification

### 2.1 System Performance Parameter

Table 2-1 The parameter of HV Battery Pack system

System List	S6	S5	S4	S3	S2	S1
System Model	BXB 30KHV	BXB 25KHV	BXB 20KHV	BXB 15KHV	BXB 10KHV	BXB 5KHV
Module Type	LFP	LFP	LFP	LFP	LFP	LFP
Total Storing Energy [kWh]	30.72	25.60	20.48	15.36	10.24	5.12
Usable Capacity [kWh]	30.72	25.60	20.48	15.36	10.24	5.12
Recommend Depth of Discharge	80%	80%	80%	80%	80%	80%
Max Depth of Discharge	100%	100%	100%	100%	100%	100%
Module configuration	6 Series	5 Series	4 Series	3 Series	2 Series	1 Series
Voltage Range [Vdc]	537.6~700.8	448~584	358.4~467.2	269.8~350.4	179.2~233.6	89.6~116.8
Battery System Voltage [Vdc]	614.4	512	409.6	307.2	204.8	102.4
Battery System Capacity [Ah]	50	50	50	50	50	50
Battery System Charge Current [A] (Standard)	30	30	30	30	30	30
Battery System Discharge lower-Voltage [Vdc]	537.6	448	358.4	269.8	179.2	89.6
Battery System Discharge Current [A] (Standard)	30	30	30	30	30	30
Discharge Temperature [°C]	-15~55	-15~55	-15~55	-15~55	-15~55	-15~55
Charge Temperature [°C]	-5~55	-5~55	-5~55	-5~55	-5~55	-5~55
Storage Temperature [°C]	-15~55	-15~55	-15~55	-15~55	-15~55	-15~55
Standard Charge & Discharge Power [kW]	18.43	15.36	12.28	9.21	6.14	3.07
Altitude [m]	≤2000	≤2000	≤2000	≤2000	≤2000	≤2000
Ingress Protection (in stacked up state)	IP55	IP55	IP55	IP55	IP55	IP55
Size [mm] (Excluding foot cups)	560*400*1606	560*400*1374	560*400*1142	560*400*910	560*400*678	560*400*446
Weight [kg]	336	284	232	180	128	76
Battery Module Name	BXBM 5KHV	BXBM 5KHV	BXBM 5KHV	BXBM 5KHV	BXBM 5KHV	BXBM 5KHV
Battery Module Quantity (pcs)	6	5	4	3	2	1
Parallel connection	10 clusters	10 clusters	10 clusters	10 clusters	10 clusters	10 clusters

The following uses four battery modules as an example:

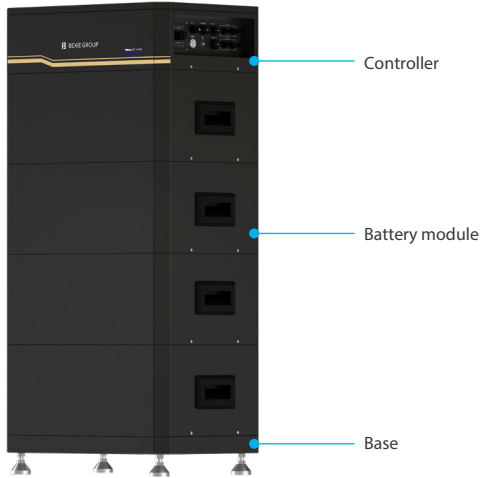

## 2.2 Battery Module



Table 2-2 Product parameters

Module Name	BXBM 5KHV
Cell Technology	Li-ion(LFP)
Battery Module Energy (kWh)	5.12
Battery Module Voltage (Vdc)	102.4
Cell Capacity (Ah)	50
Battery Module Cell Quantity (pcs)	32
Working Voltage Range (Vdc)	89.6-116.8
Charge Current (Standard) [A]	30
Discharge Current (Standard) [A]	30
Dimensions (W*D*H, mm)	560*400*273
Communication Mode	CAN
Ambient Temperature (°C)	-15~55
IP Grade	IP55
Weight (kg)	52

**BXBM 5KHV top interface**



**BXBM 5KHV bottom interface**



**Table 2-3 Interface Definition**

Item	Name	Definition
1	Connector-Socket	Battery module output and communication interface
2	Connector-Plug	Battery module output and communication interface

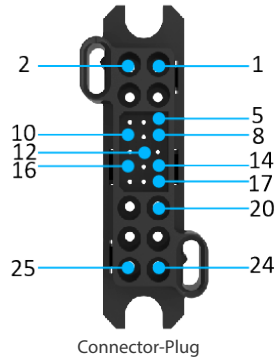
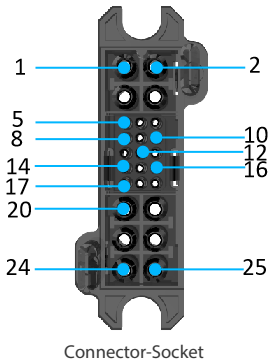

**Table 2-4 Port Definition**

Pin NO.	Connector-Socket	Connector-Plug
1	Module positive	Module negative
2	Module positive	Module negative
5	H+	H+
8	VCC+	VCC+
10	VCC -	VCC -
12	DI1	DO1
14	CAN-H	CAN-H
16	CAN-L	CAN-L
17	H-	H-
20	PE	PE
24	Negative output	Negative output
25	Negative output	Negative output

## 2.3 Controller

### Controller Front interface



Table 2-5 Display Area Definition

Item	Name	Definition
1	SOC	State Of Capacity, blue light
2	ALM	Alarm, red light
3	RUN	RUN, blue light

There are 6 LED indicator, 4 blue LED gives status of SOC, 1 red Alarm LED and 1 blue Running Status LED (indicating charging, discharging etc.)

Status	Normal/Warning/Protection	RUN	ALM	SOC	Remarks
		●	●	■	
Power Off	Hibernate	no	no	no	
Stand by	Normal	Twinkle 1	no	Real SOC	
	Warning	Twinkle 1	no		
Charging	Normal	Twinkle 2	no	Real SOC	
	Warning	Twinkle 1	no		
	Protect	no	Continuous		
	Over charging	Twinkle 1	no		
Discharging	Normal	Continuous	no	Real SOC	
	Warning	Twinkle 1	no		
	Protect	no	Continuous		
	Over Discharging	Twinkle 1	no		

Table 2-6 LED Twinkle Status

Status	On	Off
Twinkle 1	0.5s	4.0s
Twinkle 2	1.0s	1.0s
Twinkle 3	1.0s	2.0s

### Controller right interface

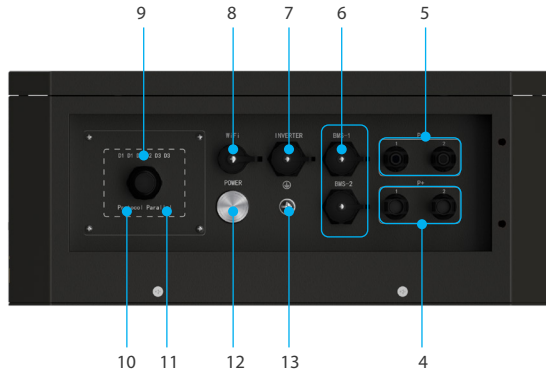

### Controller left interface

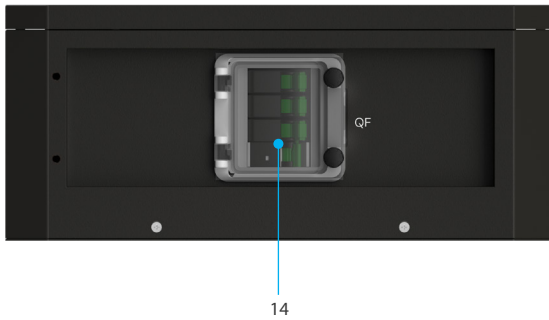

### Controller bottom interface

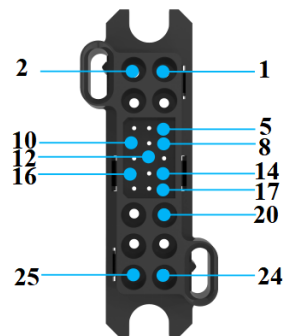

**Table 2-7 Interface Definition**

Item	Name	Definition
4	P+ output terminal	Connect battery system with Inverter positive terminal
5	P- output terminal	Connect battery system with Inverter negative terminal
6	BMS communication port	RJ45 port used to connect the upper computer and parallel Ethernet communication port
7	Inverter communication port	Connect to the communication port of the inverter
8	WiFi	WiFi module interface
9	Dry contact	Dry contacts are used to communicate critical alarms between inverters and batteries and activate batteries at 24V
10	CAN DIP switch	Dip switch for the CAN protocol circuit with inverter
11	Parallel dip switch of battery	Dip switch for battery parallel dip switch
12	Power switch	Power switch Indicates the battery activation switch
13	Ground point	PE connecting point
14	DC Breaker	The master switch of the battery system
15	Connector-Plug	Battery module output and communication interface

**Table 2-8 Controller Connector-Plug Definition**

NO	Definition
1	Battery Positive
2	Battery Positive
5	H+
8	VCC+
10	VCC-
12	DO1
14	CAN-H
16	CAN-L
17	H-
20	PE
24	Battery Negative output
25	Battery Negative output



**Controller Connector-Plug**

## 2.4 Base

Base top interface

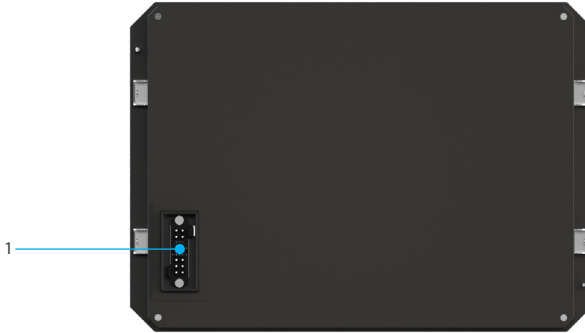
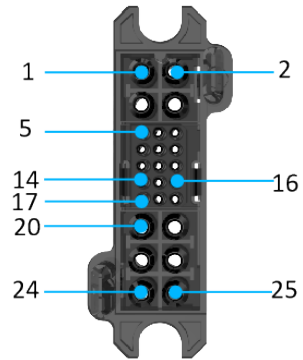

Table 2-9 Interface Definition

NO	Definition
1	Negative
2	Negative
5	H-
14	CAN-H
16	CAN-L
17	H-
20	PE
24	Negative output
25	Negative output



**CAUTION**

When the DC breaker is tripped off because of over current or short circuit, must wait after 30min to turn on it again, otherwise may cause the breaker damage.



**Power Switch:** Generally when it is at ON state, you can't turn off it during normal running condition.

**Danger:**

Ensure Power Switch is turned on before waking up the battery. Otherwise it will affect automatic checking process and cause danger.

**Danger:**

DO NOT turn off the "Power Switch" during normal running condition, only in emergency case it could be turned off directly.

Definition of "Inverter" RJ45 communication port pin.

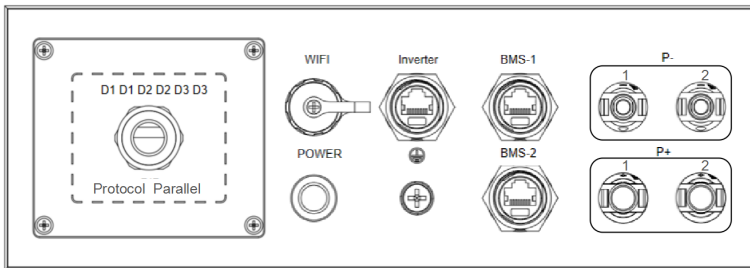

Table 2-9 Interface Definition

Inverter communication port		
	No.	Name
<p>Inverter</p>	1	Inverter-485-B
	2	Inverter-485-A
	3	ISO-GND
	4	Inverter-CAN H
	5	Inverter-CAN L
	6	ISO-GND
	7	/
	8	/

## 3 Installation

---

### 3.1 Environmental Requirement



#### 3.1.1 Cleaning

The battery system has high-voltage connectors, and environmental conditions can affect the isolation performance of the system. Before installation and system power on, the dust and iron scurf must be removed to keep a clean environment. And the environment must have certain anti-dust ability. Dust and humidity condition shall be periodic checked during the system continuous operation.



#### 3.1.2 Temperature

HV Battery Pack system working temperature range: -15°C~55°C. Optimum temperature: 15°C~30°C;  
 Caution: Out of the working temperature range will cause the battery system over / low temperature alarm or protection which may lead to the cycle life reduction.



#### 3.1.3 Cooling System

It is essential to equip a cooling system to keep the battery system in a relevant temperature range. Caution: Out of the working temperature range will cause the battery system over / low temperature alarm or protection which may lead to the cycle life reduction.



#### 3.1.4 Heating System

Danger: The module comes with a heating system. If the temperature is below 0°C and charging needs to be started, the heating system will be activated first, and the battery pack will be heated to 10°C before charging. It is necessary to turn on the heating system first.  
 Caution: Out of the working temperature range will cause the battery system over / low temperature alarm or protection which may lead to the cycle life reduction.



#### 3.1.5 Fire-extinguisher System

The room must be equipped with fire-extinguisher system for safety purpose. The fire system needs to be regularly checked to be in normal condition. Refer to the using and maintenance requirements, please follow local fire equipment guidance.



#### 3.1.6 Grounding System

Make sure the grounding point for battery system is stable and reliable before the battery installation. If the battery system is installed in an independent equipment cabin (e.g. container), must make sure the grounding of the cabin is stable and reliable.



#### 3.1.7 Requirements for Installation Location

- A solid support surface must be available (e.g., concrete or masonry).
- The installation location must be inaccessible to children.
- The installation location must be suitable for the weight and dimensions of the HV Battery Pack.
- The installation location must not be exposed to direct solar irradiation.
- Keep away from metal conductive dust.
- Keep away from water source, heat source and inflammable and explosive articles.
- The installation location must not be close to the fire.
- The operating temperature should be between -15 °C ~ +55 °C.
- The ambient humidity should be between 5-95%.

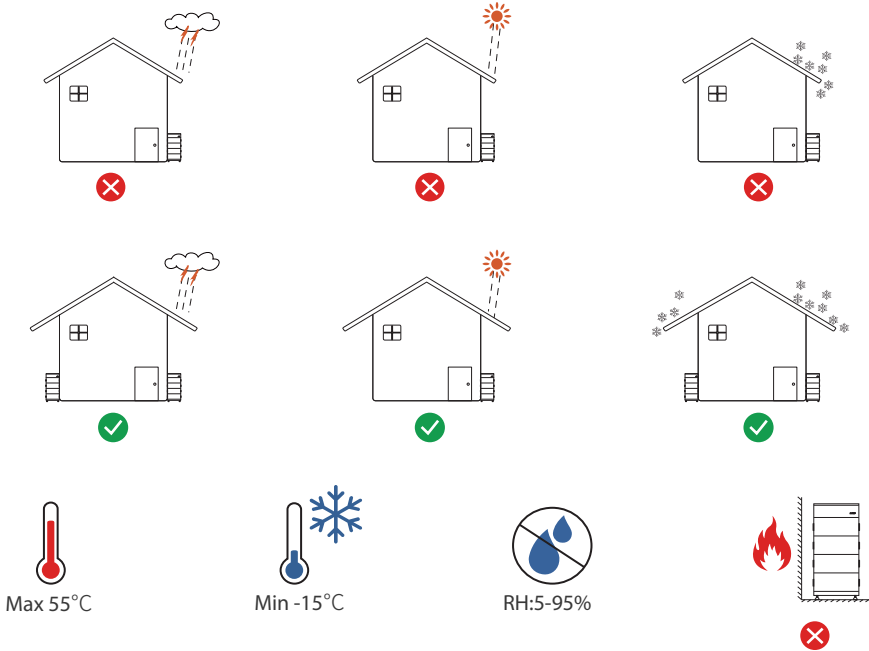

### 3.2 Recommended Installation clearance



Please note that the battery should be installed with a minimum safe clearance from the surrounding equipment or battery. Please refer to the minimum clearance diagram below.

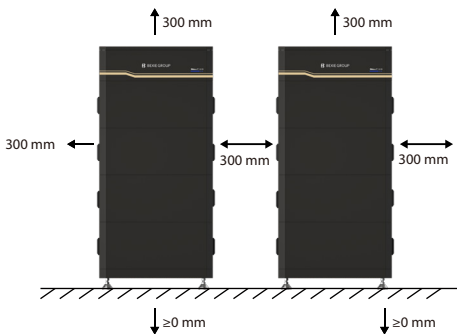

Space Requirements	
Min. clearance from left side	300 mm
Min. clearance from right side	300 mm
Min. clearance above HV Battery Pack system	300 mm
Min. clearance between side-by-side HV Battery Pack system	300 mm
Min. clearance from back	30~70 mm
Clearance at the bottom	0 mm

### 3.3 Tools

The tools in the following table could be needed during the installation.



Network Wire Clamp

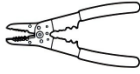

Wire Stripper



Crimping Pliers



Flat-Head Screwdriver



Torque Wrench

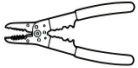

Wire Stripper



Crimping Pliers



Wrench

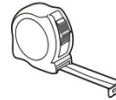

Tape Measure



Drill



Pen



Phillips Screwdriver Bit

**NOTE:**

Use properly insulated tools to prevent accidental electric shock or short circuits.

If insulated tools are not available, cover the entire exposed metal surfaces with available insulated alternatives, except their tip, with electrical tape.

### 3.4 Safety Gear

It is recommended to wear the following safety gear when dealing with the battery system.



Insulated gloves



Safety goggles



Safety shoes

### 3.5 Unpacking inspection

When the equipment arrives at the installation site, loading and unloading should be performed according to the rules and regulations, to prevent from being exposed under sunlight. Battery should not be installed in direct sunlight. Please refer to Section 3.3.

- Before unpacking, the total number of packages shall be indicated according to the shipping list attached to each package, and the case shall be checked for good condition.
- In the process of unpacking, handle with care and protect the surface coating of the object.
- Open the package, the installation personnel should read the technical documents, verify the list, according to the configuration table and packing list, ensure objects are complete and intact, if the internal packing is damaged, should be examined and recorded in detail.

Packing list is as follows:

NOTE: The four battery modules are used as reference, and the shipment is subject to actual conditions.

Item	Specification	Quantity	Figure	Remarks
HV Battery Pack Controller	Model: BXBC 5KHV	1 PCS		
Battery Module	Model: BXBM 5KHV, 102.4Vdc 50Ah	4 PCS		According to customer selection of electricity configuration
HV Battery Pack Base	Model: BXB 5KHV Base	1 PCS		Foot cups are shipped without mounting on the base
CH00	Communication cable to inverter, 1.5M	1 PCS		
	Dry contact communication cable, 1.5M	1 PCS	/	Black cable, 6-core wire
	Ground cable, 1.5M	1 PCS		
CH01	Positive power cable, 1.5M	1 PCS		
	Negative power cable, 1.5M	1 PCS		
User Manual	A5, Color printing	1 PCS	/	
Power cable connector	Positive connector	2 PCS		With crimping terminal
	Negative connector	2 PCS		With crimping terminal
Screw	Cross recessed countersunk head, M4x12	20 PCS		Each battery module is packaged with 4 pcs

Accessory	Screw, M6x12	8 PCS		
	Control box bracket	2 PCS		
	Wall mounted bracket	2 PCS		
	Casters	4 PCS		
	RJ45 Waterproof wiring terminal	3 PCS		
	Expansion Anchor Bolt (M6x60)	4 PCS		The hole diameter is 8mm and the depth is 60mm

### 3.6 Installation

#### Installation steps

Step1	Installation preparation	1. The environment is meeting all environmental requirements: "3.1.1~3.1.6"
Step2	Mechanical installation	1. Determine HV Battery Pack system placement
		2. Place the base
		3. Install battery module
		4. Install Controller
		5. Install hangers
		6. Mark the System configuration
Step3	Battery system self-test	1. Switch on the DC breaker of the Controller
		2. Switch on the "POWER" switch
		3. Press the "POWER" button for about 3S
		4. Check the system output voltage
		5. Shut down the battery system
Step4	Connecting inverter	1. Connect output Power Cable to the inverter
		2. Connect the output communication cable to the inverter
		3. Select Protocol
		4. Allocate dip switches
		5. Connect dry contact communication cable

### 3.6.1 Installation preparation

- Make sure the environment is meeting all technical requirements: “3.1.1~3.1.6”
- Prepare equipment and tools for installation.
- Confirm that the DC breaker is in the OFF state to ensure that it is no live operation.

### 3.6.2 Mechanical installation

#### 3.6.2.1 Place the base

- Choose an appropriate place to set base.
- Take the Controller and base from the package out.
- Loose the four screws with screwdriver.



- Install 4 foot cups and tighten to secure, and keep the distance of 45~75 mm between the base and and the foot cup.

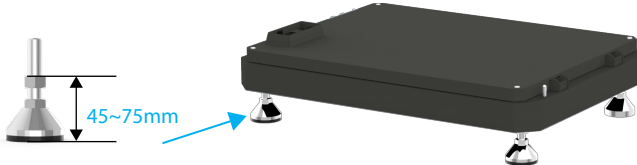

- Put the installed base and feet along the wall, and keep the distance of 30~70 mm between the wall and the base.

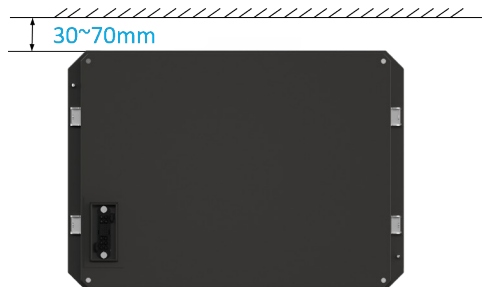

3.6.2.2 Battery module and controller installation

- Install all the BXBM 5KHV modules and controller on the base from bottom to up, follow the sequence 004~001. Referring to the following figure

Warning: Single battery module is 52kg. It's necessary to arrange more than 1 person to install battery module if without lifting equipment, more than 2 person when install battery module in higher position.

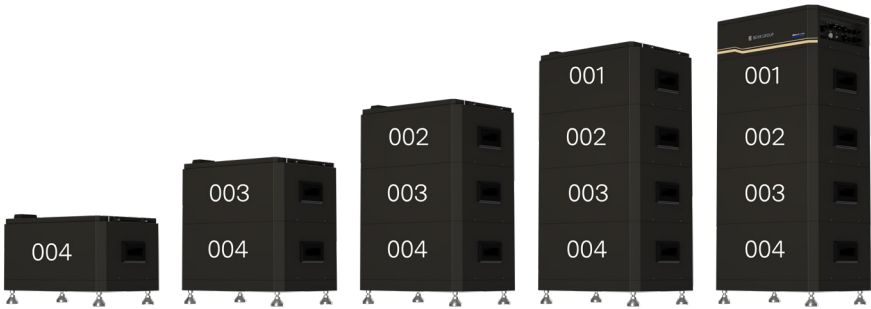

Warning: Battery module  $\Delta V$  of Single cluster should be less than 0.15V at first installation.

- Fix the connection between the battery module and the base, between battery modules and between controller and battery module. To do this, insert the screws (M4x12) through the holes on them, using a screwdriver and tighten them.

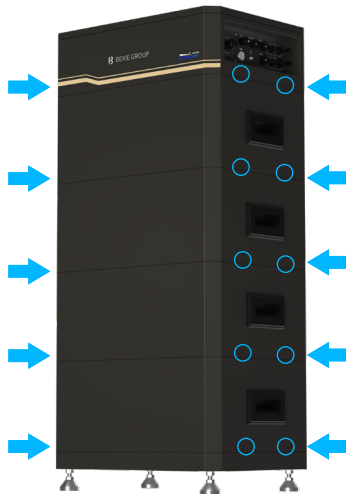

- Hold the hanger (wall part) where it intends to be mounted on the wall and mark the position of the drill holes. Please pay attention that there may be power cables or other supply lines (e.g., gas or water) routed in the wall. Ensure that no lines are laid in the wall, which could be damaged when drilling holes. Set the hanger aside and drill the marked holes.
- Insert screw anchors into the drill holes if the support surface requires them.
- Secure the hanger using screws (recommended M6x60).
- Fix the four hangers (wall parts and controller parts) with M6X12 bolts and nuts, using a cylinder screwdriver to tighten it.

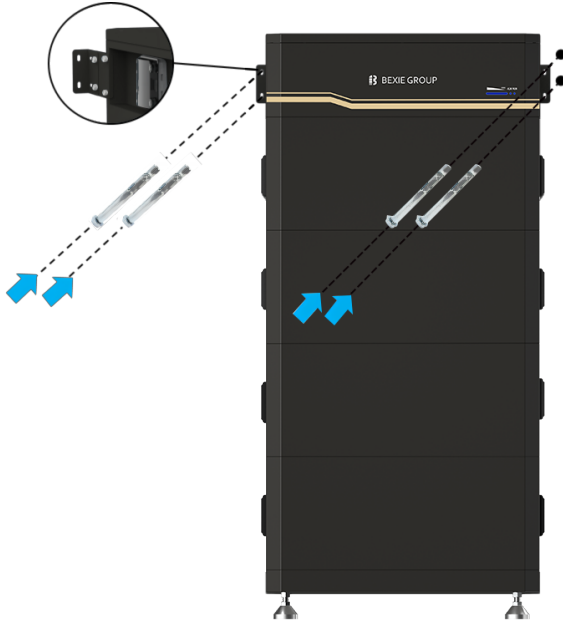

- Mark the System configuration.

**BEXIE GROUP**

Rechargeable HV Battery System  
BMS Controller Model : BXBC 5KHV  
Operation Temp : -15°C~55°C  
Input Current : 30A  
Protection Class : I  
IP Grade : IP55

Configuration/Nominal Voltage/Rated Capacity/Energy/System Model

- 1S / 102.4Vdc / 50Ah / 5.12kWh / BXB 5KHV
- 2S / 204.8Vdc / 50Ah / 10.24kWh / BXB 10KHV
- 3S / 307.2Vdc / 50Ah / 15.36kWh / BXB 15KHV
- 4S / 409.6Vdc / 50Ah / 20.48kWh / BXB 20KHV
- 5S / 512.0Vdc / 50Ah / 25.60kWh / BXB 25KHV
- 6S / 614.4Vdc / 50Ah / 30.72kWh / BXB 30KHV

SN



U C B 700 050 R2A 22 8 C 0001

BEXIE GROUP S.L.  
Email: info@bexiegroup.com  
Tel: +34 98534212  
Address: CALLE CORDONAGA 5 - 38002 OVIEDO (ASTURIAS)

**MADE IN CHINA**



2S / 204.8Vdc / 50Ah / 10.24kWh / BXB 10KHV

Example

3.6.3 Battery system self-test

3.6.3.1 Switch the Controller "DC BREAKER" to the "ON" state.

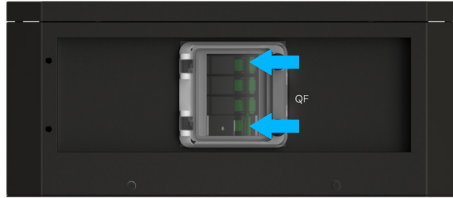

3.6.3.2 Press the "POWER" button for about 3S. The run light remains on for about 30 seconds and enters the self-test state of the lights. The panel lights are turned on by one. When the run light enters the Standby state, it indicates that the system has completed the self-test.



Press and hold on 3s

3.6.3.3 Use a multimeter to measure the output voltage on the positive and negative ports of the Controller

3.6.3.4 The output voltage should conform to the voltage range in the table "Table 2-1 The parameter of HV Battery Pack system". Otherwise, the system will be not working properly.

Use a multimeter to check the output voltage is within the normal range.

- Danger: The voltage of the battery is too high, please pay attention to do self-protection during the measurement.

3.6.4 Shut down the system.

- Switch off the "POWER" switch.



Press and hold on 3s

- Switch the Controller "DC BREAKER" to the "OFF" state .

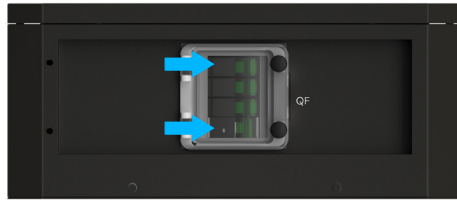

### 3.6.5 Connecting inverter

Taking 4 battery modules as an example for a single cluster

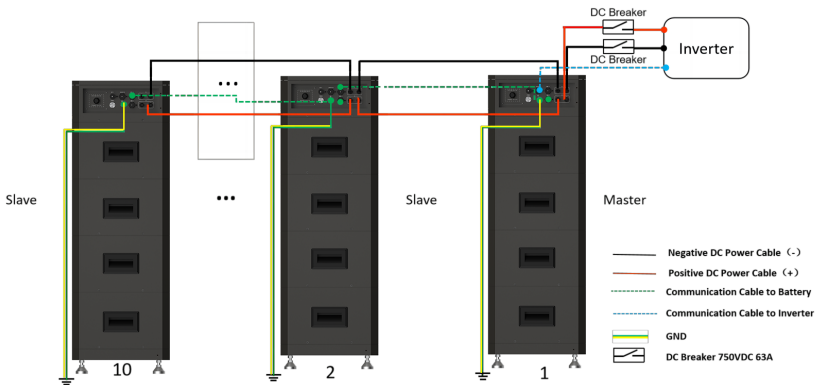

Connection mode -1  
(20\*n kWh, Output Power 12kW, n=Number of parallel clusters)  
(Battery ΔV of clusters should be less than 3V at first Parallel installation)

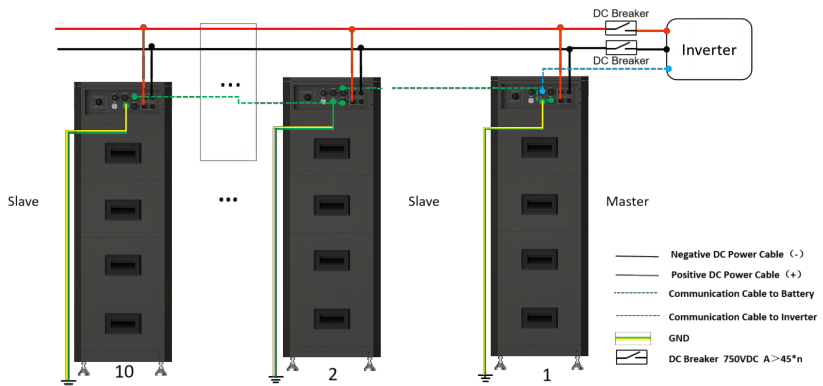

Connection mode -2  
(20\*n kWh, Output Power 12\*n kW, n=Number of parallel clusters)  
(Battery ΔV of clusters should be less than 3V at first Parallel installation)

**⚠ CAUTION**

Caution: A external DC Breaker that operates both positive and negative conductors simultaneously between the Controller and inverter on the power cable is recommended. After waking up the Controller and ensure that the Controller is pre-charged, you can turn on it.

**Danger:**

Please confirm that the battery system is in the off state before connecting. It maybe cause electric shock to personnel and damage to the inverter if connect the battery directly without power off.

- Both ends of the power cable are equipped with MC4 connectors , such as single use, the positive power cable and negative power cable one end connector cut, crimped another provided by the inverter (such as parallel use, the positive power cable and negative power cable can be directly connected to the P+ and P- of on the another Controller).

If that power cable is not long enough, please find another power cable of the same specification, the length cannot be longer than 3m.



Connect output Power Cable to the inverter;



P-,connect to inverter DC- terminal

P+,connect to inverter DC+ terminal



Connect the output communication cable to the inverter RJ45 CAN port.

- (1) Take off the RJ45 waterproof cover.
- (2) Pass the communication cable through the RJ45 wiring cover.
- (3) Plug the communication cable to the corresponding RJ45 port.
- (4) Tighten RJ45 wiring cover.

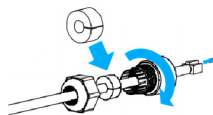

 Connect External grounding Cable to the inverter;



Connect to inverter ground point

 **WARNING**

Double check all the power cables and communication cable. Make sure the voltage of the Inverter is in the same level with the battery system.

- (1) Switch on the inverter, to make sure all the power equipments can work normally.
- (2) Start the battery system.

 Select Protocol

The controller is equipped with multiple built-in programs to follow up on the corresponding protocol for inverter model selection.

- (1) Remove 4 screws through screwdriver and then remove the cover plate.
- (2) Set Protocol dial reference dial table.

Protocol DIP switch Settings

Manufacturer	Set
BEXIE HV Protocol	1000
.....	.....

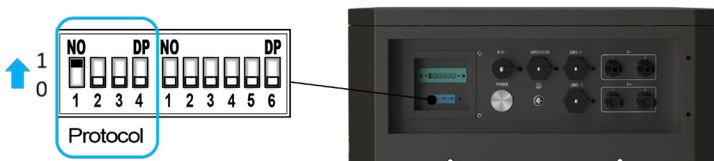
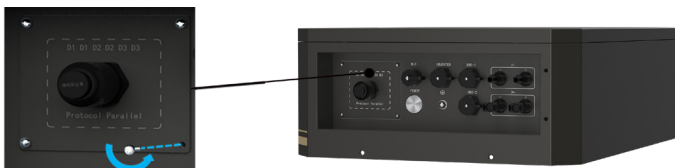



Allocate dip switches;

There HV Battery Pack can be used as single cluster as well as clusters (in parallel) mode.



	Master	Slave 1	Slave 2	Slave 3	Slave 4	Slave 5	Slave 6	Slave 7	Slave 8	Slave 9
1 Master 0 Slave	000001									
1 Master 1 Slave	100001	100000								
1 Master 2 Slave	010001	100000	010000							
1 Master 3 Slave	110001	100000	010000	110000						
1 Master 4 Slave	001001	100000	010000	110000	001000					
1 Master 5 Slave	101001	100000	010000	110000	001000	101000				
1 Master 6 Slave	011001	100000	010000	110000	001000	101000	011000			
1 Master 7 Slave	111001	100000	010000	110000	001000	101000	011000	111000		
1 Master 8 Slave	000101	100000	010000	110000	001000	101000	011000	111000	000100	
1 Master 9 Slave	100101	100000	010000	110000	001000	101000	011000	111000	000100	100100



Connect dry contact communication cable (Not necessary, if the inverter end does not have this function, there is no need for wiring);

Dry contact PIN definition

	Description
Dry contact	1: Inverter failure input 24V+
	2: Inverter failure input 24V-
	3: Conduction, Battery failure output inverter
	4: Conduction, Battery failure output inverter
	5: Battery activation input 24V+
	6: Battery activation input 24V-

- (1) Pull out the PG head sealant plug.
- (2) Turn counterclockwise to loosen PG head cover.
- (3) Thread the dry contact communication line through the PG head and connect it to the corresponding PIN.
- (4) Tighten the PG head cover clockwise.

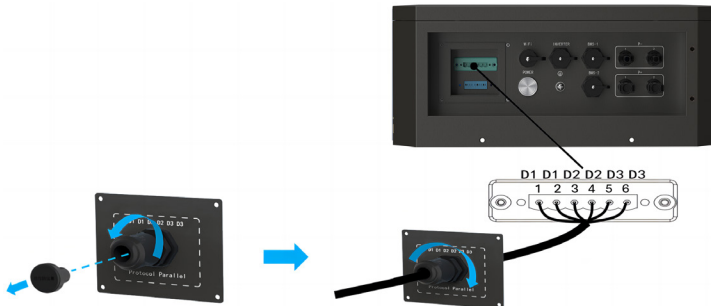

## 4 Maintenance

### 4.1 Trouble Shooting



The HV Battery Pack battery system is a high voltage DC system, operated by professional and authorized person only.

Before check the failure, must check all the cables connection. Switches are right or not, and if the battery system can be woken up normally.

No	Problem	Possible Reason	Solution
1	The battery has no voltage output, and "POWER" Light is off.	The DC breaker of the Controller didn't be turned on	Turn on the DC breaker of Controller
2		The "POWER" switch of the Controller box was not switched on	Switch on the "POWER" button
3		Battery is in sleep state	Long press the "POWER" button for about 3S
4		The fuse in the Controller box is faulty	Replace fuse
5		Battery gets into over-discharged protection	Charge the battery to relieve the protection state
6	The battery has no voltage output, but "POWER" is on	The relay in Controller is faulty	Replace a new Controller directly
7	When the battery is connected to the inverter, the DC breaker trips automatically	The circuit between the battery and the inverter has a short circuit point	Check for short circuits between the battery and the inverter. Also, check whether the inverter is faulty.
8	Communication failure between battery and inverter	The wrong battery model type is selected on the inverter	Select correct battery model type on the inverter
9		Communication cable interruption	Replace communication cable
10		PIN error in communication cable between inverter and battery	Replace with the cable corresponding to the CAN signal (the battery side CAN is 4H5L)
11		Error dialing code on the control box	On the dialing board, use the normal protocol to dial the code

## 4.2 Replacement of main component

**⚠ DANGER**

The HV Battery Pack battery system is a high voltage DC system, only can be operated by professional and authorized person.

### 4.2.1 Replacement of Controller

4.2.1.1 Turn off the whole battery system. Ensure the Negative terminal and Positive terminal have no power.

4.2.1.2 Remove the four screws on the Controller, then remove the Controller from the system.



4.2.1.3 Change a new Controller. Then fix four screws.

## 4.3 Battery Maintenance

**⚠ DANGER**

The maintenance of battery only can be operated by professional and authorized person . you need turn off the battery system firstly when you do some maintenance items.

### 4.3.1 Voltage Inspection

[Periodical Maintenance] Check the voltage of battery system through the monitor software. Check whether the system voltage is normal or not. For example: Check Single cell's voltage is out of rated range or not.

### 4.3.2 SOC Inspection

[Periodical Maintenance] Check the SOC of battery system through the monitor software. Check the SOC of battery string is normal or not.

### 4.3.3 Cables Inspection

[Periodical Maintenance] Visual inspect all the cables of battery system. Check the cables have broken, aging, getting loose or not.

### 4.3.4 Balancing

[Periodical Maintenance] The battery system will become unbalanced if have not be charged fully for a long time. Solution: Preform the balancing maintenance (fully charged) every 3 month. Generally this maintenance progress needs to be completed when external devices such as the monitor software and battery and inverter are in good communication.

### 4.3.5 Output Relay Inspection:

[Periodical Maintenance] Under low load condition (low current), control the output relay OFF and ON to hear the relay has click voice, that's mean this relay can off and on normally.

## 5 Storage Recommendations

- It is recommended that batteries not be stored for a long period. They should be used soon after being deployed onsite. The batteries should be handled according to the following requirements.

Required Storage Temperature	Actual Storage Temperature	Recharge Interval	Remarks
-15°C < T ≤ 55°C	T ≤ -15°C	Not allowed	Not reaching the time for recharge: Use the batteries as soon as possible.  Reaching the time for recharge: Recharge the batteries.
	-15°C < T ≤ -10°C	6 months	
	-10°C < T ≤ +25°C	12 months	
	25°C < T ≤ 35°C	9 months	
	35°C < T ≤ 55°C	6 months	
	55°C < T	Not allowed	



### CAUTION

The cycle life of the battery will have relative heavily reduction if not follow the above instructions to store the battery for a long term.

## 6 Shipment

Battery module will pre-charged to 50% SOC or according to customer requirement before shipment. The remaining capacity of battery cell is determined by the storage time and condition after shipment.

- The battery modules meet the UN38.3 certificate standard.
- In particular, special rules for the carriage of goods on the road and the current dangerous goods law, specifically ADR (European Convention on the International Carriage of Dangerous Goods by Road), as amended, must be observed.

